

► Benutzerhandbuch/ User's Manual



KISS Short

User's Manual
Version 1.00

Kontron Embedded Computers GmbH

0-0096-3623

Contents

Introduction	3
Symbols used in this Manual	4
Important Instructions	5
Note on the Warranty.....	5
Exclusion of Accident Liability Obligation.....	5
Liability Limitation / Exemption from the Warranty Obligation	5
Safety Instructions	6
Operation of Laser Source Devices	8
Electrostatic Discharge (ESD)	8
Grounding Methods.....	9
Instructions for the Lithium Battery	9
FCC Statement.....	10
Electromagnetic Compatibility.....	10
Scope of Delivery	11
Type Label and Product Identification.....	11
Product Description	12
Front Side	18
Operating Elements	20
Interfaces on the Front Side	21
LED Indicators.....	21
Front Access Panel	22
Filter Mat Holder.....	22
External Accessible Drive Bays.....	22
External Accessible Slim-Line or Internal 3.5" Drive Bay (Option).....	22
Rear Panel.....	23
Interfaces on the Rear Side.....	25
Power Supply Unit.....	28
Fan Slide-In Module and Temperature Sensors.....	29
Side View.....	29
Integrated Motherboard / SBC.....	30
Backplane (for Configuration with SBC)	31
Assembly, Disassembly	32
Attaching the Rubber Feet.....	32
Removing the Drive Locking Screws	32

Accessing Internal Components.....	33
Installing/Removing the Expansion Cards	33
Instruction for Installation in a 19" Cabinet	37
Starting Up.....	39
Power Cord Connection	39
Operating System and Hardware Components Drivers.....	40
Maintenance and Prevention	41
Replacing the System's Fans.....	42
Cleaning the Filter Mat	45
Replacing the Lithium Battery	47
Slide Rails (Option).....	48
Slide Rails Accessories and Assembling.....	49
Device Mounting into an Industrial Cabinet (with Slide Rails).....	50
Main Specifications.....	51
Electrical Specifications	52
Mechanical Specifications.....	52
Environmental Specifications	53
CE Directives and Standards	54
Standard Interfaces - Pin Assignments	55
COM1 / COM2 (RS232)	55
Parallel Port	56
PS/2 Mouse Connector	57
PS/2 Keyboard Connector	57
VGA Port.....	58
USB Port.....	58
Technical Support.....	59
Returning Defective Merchandise	60

Introduction

Kontron Embedded Computers would like to point out that the information contained in this manual may be subject to technical alteration, particularly as a result of the constant upgrading of Kontron Embedded Computers products. The attached documentation does not entail any guarantee on the part of Kontron Embedded Computers with respect to technical processes described in the manual or any product characteristics set out in the manual. Kontron Embedded Computers does not accept any liability for any printing errors or other inaccuracies in the manual unless it can be proven that Kontron Embedded Computers is aware of such errors or inaccuracies or that Kontron Embedded Computers is unaware of these as a result of gross negligence and Kontron Embedded Computers has failed to eliminate these errors or inaccuracies for this reason. Kontron Embedded Computers expressly informs the user that this manual only contains a general description of technical processes and instructions which may not be applicable in every individual case. In cases of doubt, please contact Kontron Embedded Computers.

This manual is protected by copyright. All rights are reserved by Kontron Embedded Computers. Copies of all or part of this manual or translations into a different language may only be made with the prior written consent of Kontron Embedded Computers. Kontron Embedded Computers points out that the information contained in this manual is constantly being updated in line with the technical alterations and improvements made by Kontron Embedded Computers to the products and thus this manual only reflects the technical status of the products by Kontron Embedded Computers at the time of printing.

© 2006 by Kontron Embedded Computers

Printing and duplication, even of sections, is only permissible with the express approval of

Kontron Embedded Computers GmbH
Oskar-von-Miller-Str. 1

85385 Eching
Germany

Symbols used in this Manual

Symbol

Meaning



This symbol indicates the danger of injury to the user or the risk of damage to the product if the corresponding warning notices are not observed.



This symbol indicates that the product or parts thereof may be damaged if the corresponding warning notices are not observed.



This symbol indicates general information about the product and the user manual.



This symbol indicates detail information about the specific product configuration.

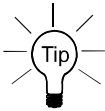

This symbol precedes helpful hints and tips for daily use.

Important Instructions

This chapter contains instructions which must be observed when using your KISS Short.

The manufacturer's instructions provide useful information on your KISS Short.

Note on the Warranty

Due to their limited service life, parts which by their nature are subject to a particularly high degree of wear (wearing parts) are excluded from the warranty beyond that provided by law. This applies to batteries, for example.

Exclusion of Accident Liability Obligation

Kontron Embedded Computers shall be exempted from the statutory accident liability obligation if the user fails to observe the safety instructions.

Liability Limitation / Exemption from the Warranty Obligation

In the event of damage to the device caused by failure to observe the hints in this manual and on the device (especially the safety instructions), Kontron Embedded Computers shall not be required to honor the warranty even during the warranty period and shall be exempted from the statutory accident liability obligation.



Safety Instructions

Please read this section carefully and observe the instructions for your own safety and correct use of the device.

The chapter also contains information on approval and interference suppression of your system.

Observe the warnings and instructions on the device and in the manual. The device has been built and tested by Kontron Embedded Computers in accordance with EN 60950/VDE 0805 and left the company in a perfectly safe condition.

In order to maintain this condition and ensure safe operation, the user must observe the instructions and warnings contained in this manual.

Caution:

Energy hazards > 240 VA are present inside the chassis!!!

Only qualified personnel and/or by Kontron Embedded Computer authorized persons are permitted to work inside the system or handling expansion cards!!!!

- Maintenance or repair on the open device may only be carried out by qualified personnel authorized by Kontron Embedded Computers which is aware of with the associated dangers.
- The device may only be opened for the installation and removal of AGP/PCI cards in accordance with the description in this manual. These procedures have to be carried-out only by qualified specialist personnel.
- If extensions are made to the device the legal stipulations and the device specifications must be observed.
- The device must be switched off and the power cord disconnected from the power source before insertion of any expansion cards.
- The unit is not completely disconnected from the main power source by turning it off via the power ATX power button.
The unit is only completely disconnected from the main power source when the power cord is disconnected either from the power source or from the unit. Therefore, the power cord and its connectors must always remain easily accessible.

- The device must be used in accordance with the instructions for use.
- The electrical installations in the room must comply with the requirements of the respective regulations.
- Take care that there are no cables, particularly power cables, in areas where persons can trip over them.
- Do not use a power cable in sockets shared by a number of other power consumers. Do not use an extension cable.
- Only use the power cable supplied.
- Do not place the device near heat sources or in a damp location. Make sure the device has adequate ventilation.
- Only devices and components which fulfill the requirements of a SELV circuit (Safety Extra Low Voltage) in accordance with EN60950 may be connected to the interfaces of the system.
- All plugs on the connection cables must be screwed or locked to the housing.
- The device is designed to be used in horizontal position.
- Only original accessories approved by Kontron Embedded Computers may be used.
- It must be assumed that safe operation is no longer possible
 - if the device has visible damage or
 - if the device no longer functions.In these cases the device must be shut down and secured against unintentional operation.

Operation of Laser Source Devices

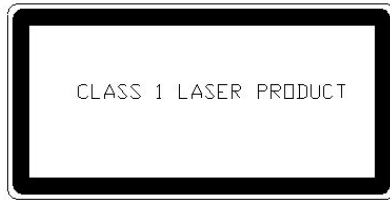

Fig. 1: Warning about laser radiation

The optional CD ROM and DVD drives contain light-emitting diodes (classified in accordance with EN 60825-1/A2.2001: LASER CLASS 1) and therefore must not be opened.

If the enclosure of such a drive is opened, invisible laser radiation is emitted. Do not allow yourself to be exposed to this radiation.

The laser system meets the code of Federal Regulations 21 CFR, 1040 for the USA and the Canadian Radiation Emitting Devices Act, REDR C 1370.



Electrostatic Discharge (ESD)

A sudden discharge of electrostatic electricity can destroy static-sensitive devices or micro-circuitry. Therefore proper packaging and grounding techniques are necessary precautions to prevent damage. Always take the following precautions:

1. Transport boards in ESD-safe containers such as boxes or bags.
2. Keep electrostatic sensitive parts in their containers until they arrive at the ESD-safe workplace.
3. Always be properly grounded when touching a sensitive board, component, or assembly.
4. Store electrostatic-sensitive boards in protective packaging or on antistatic mats.

Grounding Methods

Guard against electrostatic damage at the device by following these steps:

1. Cover workstations with approved anti-static material. Provide a wrist strap connected to a work surface and properly grounded tools and equipment.
2. Use anti-static mats, heel straps, or air ionizes to give added protection.
3. Handle electrostatic-sensitive components, boards, and assemblies by the case or the PCB edge.
4. Avoid contact with pins, leads, or circuitry.
5. Turn off power and input signals before inserting and removing connectors or test equipment.
6. Keep work area free of non-conductive materials such as ordinary plastic assembly aids and Styrofoam.
7. Use field service tools, such as cutters, screwdrivers, and vacuums that are conductive.
8. Always place drives and boards PCB-assembly-side down on the foam.

Instructions for the Lithium Battery

The installed motherboard or SBC is equipped with a Lithium battery. For the replacing of this battery please observe the instructions described in the chapter "Replacing the Lithium Battery".



Warning

Danger of explosion when replacing with wrong type of battery. Replace only with the same or equivalent type recommended by the manufacturer.



Do not dispose of lithium batteries in general trash collection. Dispose of the battery according to the local regulations dealing with the disposal of these special materials, (e.g. to the collecting points for dispose of batteries).

FCC Statement

This equipment has been tested and found to comply with the limits for a Class A digital device, pursuant to Part 15 of the FCC Rules. These limits are designed to provide reasonable protection against harmful interference when the equipment is operated in commercial environment. This equipment generates, uses, and can radiate radio frequency energy and, if not installed and used in accordance with the instruction manual, may cause harmful interference to radio communications. Operation of this equipment in residential area is likely to cause harmful interference in which case the user will be required to correct the interference at his own expense.

Electromagnetic Compatibility

This product has been designed for industrial, commercial and office use, including small business use. The most recent version of the EMC guidelines (EMC Rules 89/336/EEG) and/or the German EMC laws apply. If the user modifies and/or adds to the equipment (e.g. installation of add-on cards), the prerequisites for the CE conformity declaration (safety requirements) may no longer apply.

Scope of Delivery

- KISS Short (corresponding the ordered configuration)
- This user's manual
- Two keys for the front door lock
- Power cord
- Rubber feet (self-adhesive)
- 2x Serial port and cable connectors attached to a mounting bracket [only for KISS Short version with ePCI-101 SBC (2-A0E1-0000)]

Optional Parts

- Slide rails

Type Label and Product Identification

The type label of the KISS Short is placed on the right side of the unit.

System Type	Product designation	Product identification
KISS Short	2-A0E1-0000	KISS Short with ePCI-101 SBC
KISS Short	2-A0E2-0000	KISS Short with 886LCD-M/Flex motherboard

Product Description

KISS Short is a scalable 4U (19") Platform, that can be alternatively equipped with a motherboard or a single board computer (SBC). The KISS Short hardware can be flexibly configured corresponding to the customized requirements. In addition, the sturdy design with excellent mechanical stability, provides the demanding characteristics required for a computer, that is suitably for using in harsh industrial environment.

The KISS Short is designed to be installed in 19" racks. It is also offered as desktop version.

Versions of KISS Short:



Fig. 2: Rackmount version with closed access door



Fig. 3: Desktop version with closed access door



Fig. 2a: Rackmount version with opened access door



Fig. 3a: Desktop version with opened access door

The system can be equipped (depending on the ordered configuration) with four drive bays (one internal 3.5" or one front accessible Slim drive bay and three front accessible 5.25" drive bays).

The operating elements of the KISS Short are located behind the front access door and consist of the "ATX power button" and the "Reset-button" for the standard configuration.

The LED-indicators are located on the front side; for the standard version these are composed of the "power LED" and "hard disk activity LED".

The system fans (2 off) are installed at the front side of the unit. These are attached to the system by means of a fan slide-in module. The fan slide-in module simplifies the installation and removal of these components, also during operation.

The washable filter mat, which protects your system against dust and dirt is located behind the air grilles of the front access door. The outside accessible filter mat is changeable while the KISS Short is powered-up.

The type label is attached to the right side of the unit.



Fig 4: KISS Short



When switching on the system, make sure that the air intake and exhaust openings are not obstructed.



Before the system is put for the first time into operation (before mounting / installation into an industrial cabinet), you have to open the unit as described in the "Accessing Internal Components" section and to remove the drive locking screws (fig. 5, 5a, pos. 14 and fig. 6, 6a pos. 12).

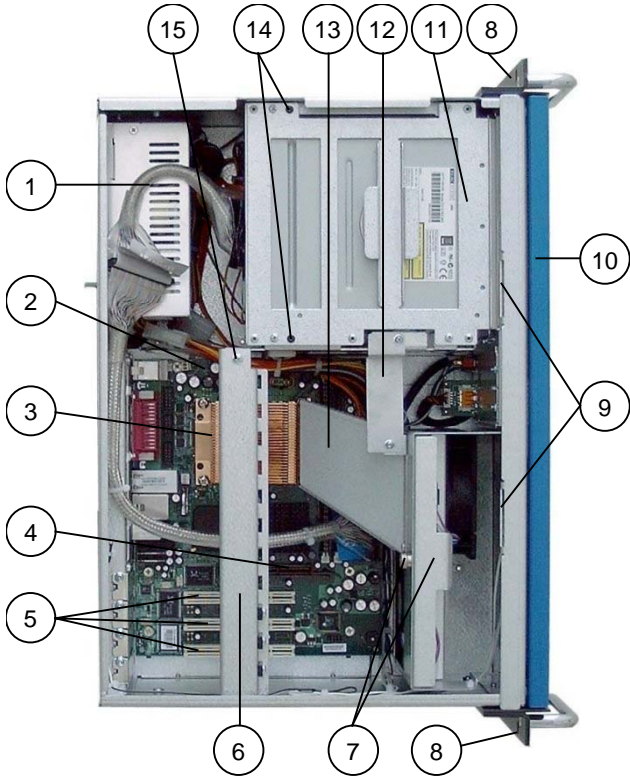

Fig 5: KISS Short, opened rackmount version (with motherboard)

Legend for figures: 5 and 5a

- | | |
|--|---|
| 1 Power supply unit | 11 Drive cage for 3x 5.25" drive bay and 1x 3.5" internal drive bay |
| 2 Motherboard | 12 Cross-tie bar between the drive cage and the air baffle |
| 3 CPU cooler (without fan) | 13 Air baffle |
| 4 Free AGP x4 expansion slot | 14 Drive locking screws of the 5.25 drive cage |
| 5 Free PCI expansion slots | 15 Fastening screw for the card holder |
| 6 Cards holder | 16 External interfaces of the motherboard |
| 7 Fan slide-in module with captive knurled screw | 17 Grounding stud |
| 8 19" rack mountable bracket with handle (not available desktop version) | 18 Expansion card slots |
| 9 Guide openings for the cover | |
| 10 Front access panel | |

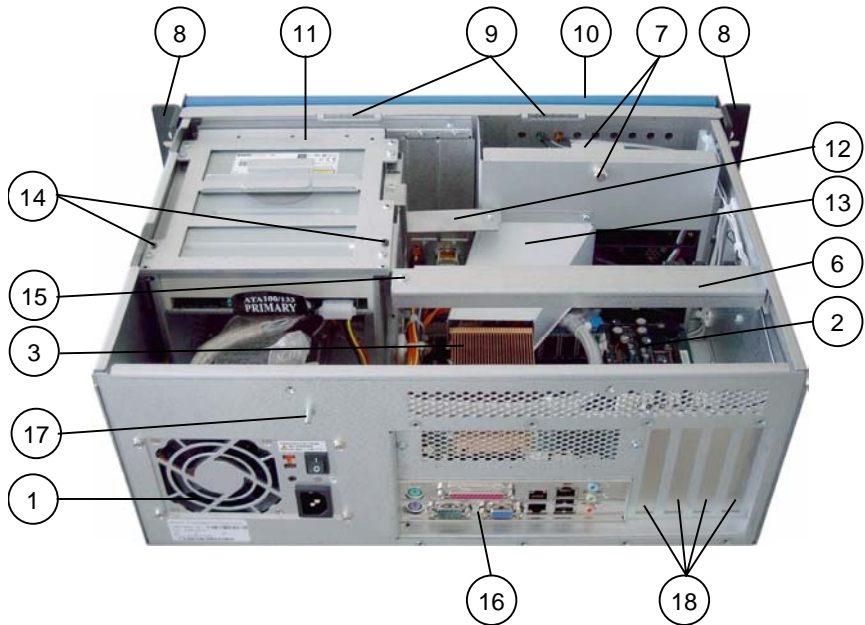

Fig 5a: KISS Short, opened rackmount version (with motherboard)



When switching on the system, make sure that the air intake and exhaust openings are not obstructed.



Before the system is put for the first time into operation (before mounting / installation into an industrial cabinet), you have to open the unit as described in the "Accessing Internal Components" section and to remove the drive locking screws (fig. 5, 5a, pos. 14 and fig. 6, 6a pos. 12).

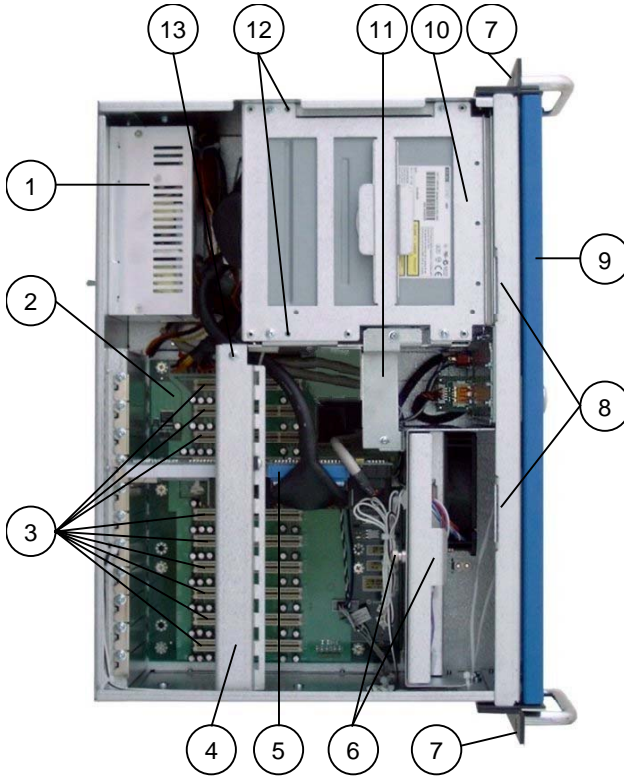

Fig.6: KISS Short, opened desktop version (with SBC)

Legend for figures: 6 and 6a:

- | | |
|--|---|
| 1 Power supply unit | 10 Drive cage for 3x 5.25" drive bay and 1x 3.5" internal drive bay |
| 2 Backplane | 11 Cross-tie bar between the drive cage and the fan slide-in module |
| 3 Free expansion PCI-slots | 12 Drive locking screws of the 5.25 drive cage |
| 4 Cards holder | 13 Fastening screw for the card holder |
| 5 SBC (Single Board Computer) | 14 External interfaces of the SBC |
| 6 Fan slide-in module with captive knurled screw | 15 Grounding stud |
| 7 19" rack mountable bracket with handle (not available for desktop version) | 16 Expansion card slots |
| 8 Guide openings for the cover | |
| 9 Front access panel | |

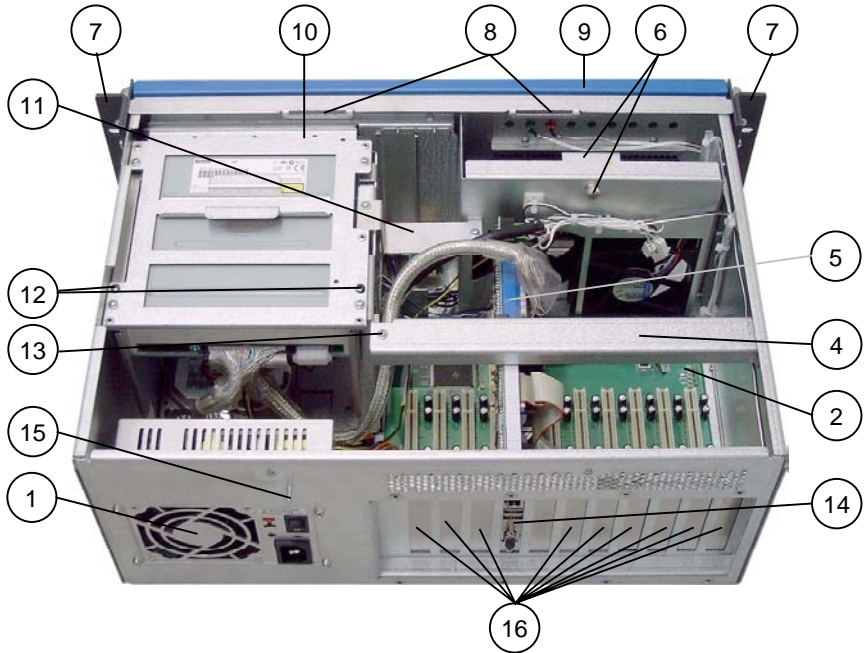

Fig. 6a: KISS Short, opened rackmount version (with SBC)



When switching on the system, make sure that the air intake and exhaust openings are not obstructed.



Before the system is put for the first time into operation (before mounting / installation into an industrial cabinet), you have to open the unit as described in the "Accessing Internal Components" section and to remove the drive locking screws (fig. 5, 5a, pos. 14 and fig. 6, 6a pos. 12).

Front Side

The system is available in rackmount version.

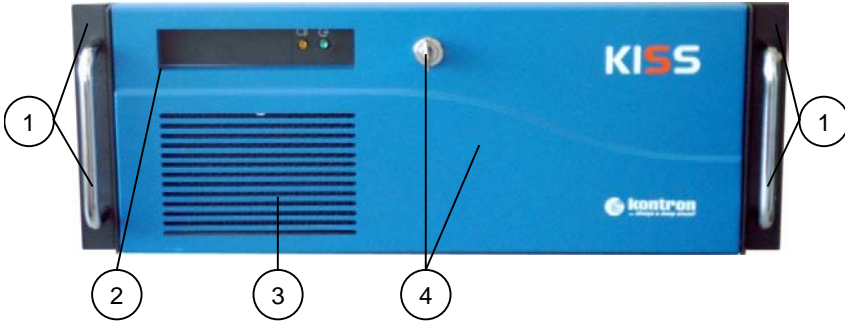
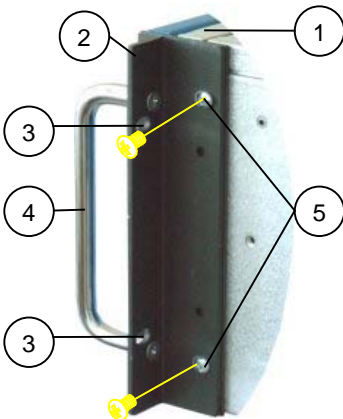

Fig. 7: Front side (rackmount version) with closed front access panel

- | | |
|---|---|
| 1 19" rack mountable bracket with handle
(not available for tower version) | 3 Air grilles |
| 2 Cut-out for LED indicators | 4 Front access panel with
lock mechanism |

You can convert your system to a desktop unit by removing the two 19" rack mountable bracket with handle (one handle bracket on each side).



- | |
|--|
| 1 Chassis of the KISS Short |
| 2 19" rack mountable bracket with
handle |
| 3 Holes for mounting in rack cabinets |
| 4 Handles |
| 5 Screws for fastening the 19" rack
mountable bracket |

Fig. 8: 19" rack mountable bracket
with fastening screws

The operating elements (ATX power button and reset button), the USB interfaces and the integrated drives are located at the front side of the KISS Short, behind the front access panel.

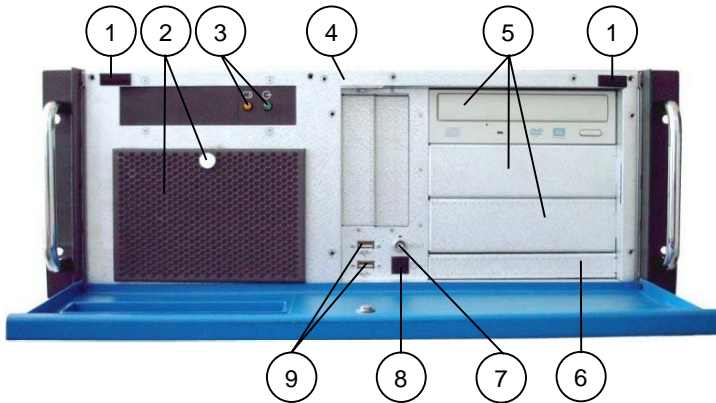
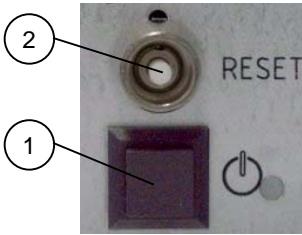

Fig. 9: Front side (rackmount version) with opened front access panel

- | | |
|--|--|
| 1 Buffer for the front access panel | 6 1x internal 3.5 drive bay" or
1x external accessible Slim-drive bay |
| 2 Bracket with knurled screw for the air filter mat | 7 Reset button |
| 3 LED indicators | 8 ATX power button |
| 4 Slot for the locking mechanism | 9 2x USB (2.0/1.1) interface |
| 5 3x 5.25" external accessible drive bay (shown with one equipped DVD-drive) | |

Operating Elements



- | | |
|---|------------------|
| 1 | ATX power button |
| 2 | Reset button |

Fig. 10: Operating elements

ATX Power Button	Use this button to turn the system on or off.
Reset Button	If your system no longer reacts, you have to restart the KISS Short. Press the reset button to restart your system.



When resetting all data in the main memory is erased. The system restarts without having to turn the computer off and on again.



Even if you turn off the system via the ATX power button, there is still a standby-voltage of 5 V on the SBC.

The system is not completely disconnected from the main power source by turning it off via the ATX power button.

The unit is complete disconnected from the main power source, only when:

- the power cord is disconnected either from the power source or the unit

or

- the On/Off power switch of the power supply unit is switched "Off".

Therefore, the power cord and its connectors must always remain easily accessible.

Interfaces on the Front Side

USB Interfaces

KISS Short is equipped with two USB 2.0 interfaces at the front side. These connectors allow you to connect USB-compatible devices to the KISS Short.

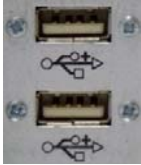
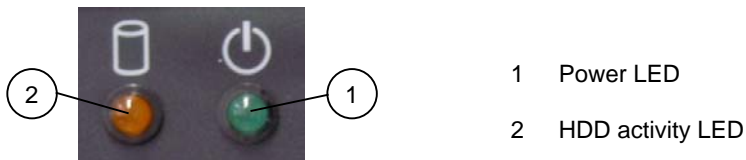

Fig. 11: USB ports on the front side

LED Indicators

The KISS Short is equipped with two LED indicators (front side).



- 1 Power LED
- 2 HDD activity LED

Fig. 12: LED indicators

LED Indicators	
Power LED (green)	Lights up when the system is powered on via the “ATX power button”. Prerequisite: The system must be attached by means of the power cord to an appropriate power source. The power switch of the PSU located on the rear side of the unit must be set to “On”.
HDD Activity LED (orange)	Indicates hard disk activity.



Do not press the disk eject while the disk drive LED is lit or blinking.

Front Access Panel

The externally accessible drive and the operating elements of the KISS Short can be protected by means of the front access panel. This panel is equipped with a securing lock mechanism.



The front access panel cannot be closed if USB devices are connected to the USB interfaces.



The key should be kept somewhere to be not accessible to unauthorized persons.
The KISS Short comes equipped with two keys. If the keys get lost or damaged, then the front access panel can only be opened by Kontron Embedded Computers service personnel.

Filter Mat Holder

The filter mat holder is located behind the air grilles of the front access panel. The filter mat is inserted in the air filter holder. The filter mat protects your system against dust and dirt. The filter mat is exchangeable while the system is powered-up. (see “Cleaning the Filter Mat“ section).

External Accessible Drive Bays

The KISS Short can be equipped with up to three 5.25“ external accessible drives (horizontal position).

External Accessible Slim-Line or Internal 3.5“ Drive Bay (Option)

The KISS Short desktop or rackmount version can be optionally equipped with:

- 1x internal, not visible from the outside, 3.5“ drive bracket in horizontal position (for IDE/SCSI/SATA hard disk drive)
or
- 1x external accessible slim-drive bay in horizontal position.

Rear Panel

Depending on the ordered KISS Short configuration, at the rear side are situated the external interfaces of the integrated motherboard or SBC, the additional interfaces (only in system configuration with SBC), the power supply unit and the air exhaust openings.



The order or the number of the KISS Short interfaces can be different depending on the device configuration.

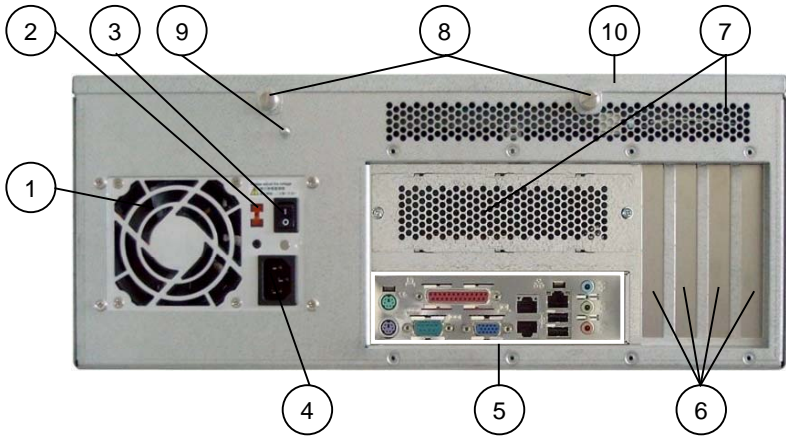

Fig. 13: KISS Short rear side (with motherboard)

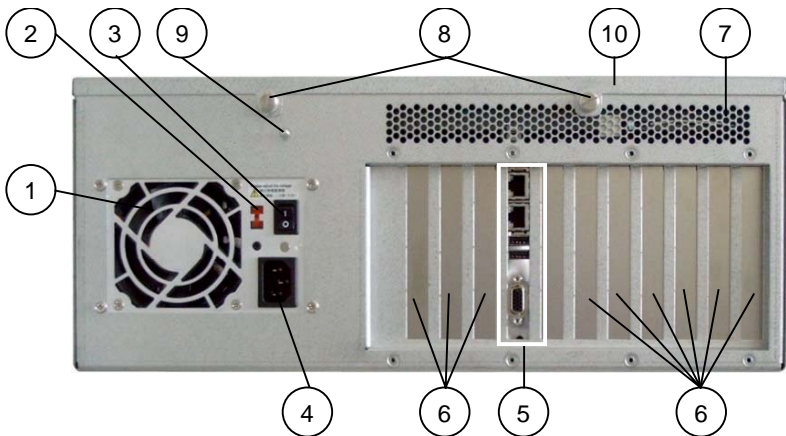

Fig. 13a: KISS Short - rear side (with SBC)

Legend for figures: 13 and 13a:

- | | | | |
|---|--|----|---|
| 1 | Fan of the PSU | 6 | free expansion card slots: 32 bit
(depending on the integrated
board) |
| 2 | Voltage selector switch (115V/230V) | 7 | Air exhaust openings |
| 3 | On/Off switch of the PSU | 8 | Captive knurled screws to secure
the cover |
| 4 | AC power plug | 9 | Grounding stud |
| 5 | Interfaces of the SBC or of the
motherboards (depending on the
system configuration) | 10 | Device cover |

Interfaces on the Rear Side



The order and the number of the KISS Short interfaces can be different depending on the device configuration.

External Interfaces of the integrated Motherboard



For detailed information refer to the user's manual of the 886LCD-m/Flex motherboard. The user's manual of the motherboard can be downloaded from our web page www.kontron-EMEA.com. Search for the name of the motherboard.

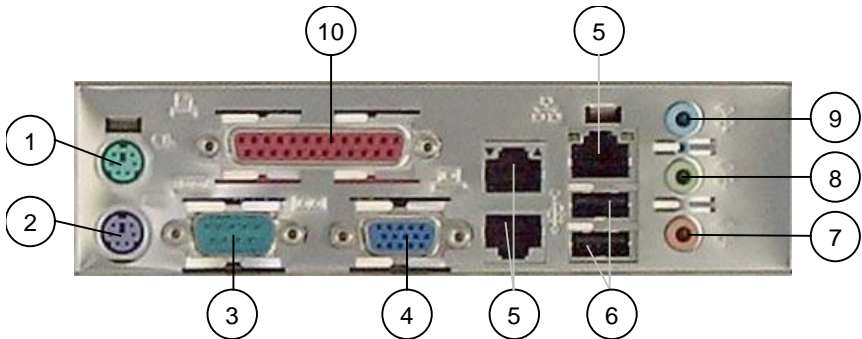

Fig. 14: Rear side – Interfaces of the Kontron 886LCD-M/Flex motherboard

- | | |
|-------------------------------------|-------------------------------|
| 1 PS/2 mouse connector (green) | 6 2x USB 2.0/1.1 connectors |
| 2 PS/2 keyboard connector (mauve) | 7 Microphone connector (pink) |
| 3 Serial interface connector (COM1) | 8 Line-out connector (green) |
| 4 VGA interface connector | 9 Line-in connector (blue) |
| 5 3x Ethernet interface (RJ45) | 10 Parallel interface (LPT) |

PS/2 Mouse Connector (green)

You can connect a PS/2-compatible mouse to the Mini-DIN connector (female).

PS/2 Keyboard Connector (mauve)

You can connect a PS/2-compatible keyboard to the Mini-DIN connector (female).

Serial Interface Connector COM1

This RS232 connection is available as a 9-pin D-SUB plug and allows to connect a serial peripheral.

VGA Interface Connector

An external (analog) monitor can be plugged into this interface which is provided as a 15-pin D-SUB socket.

Ethernet Interface Connectors

The KISS Short is equipped with three LAN connectors. These interface connectors are provided as RJ45-sockets and supports a data transfer rate of 10/100 Mbps.

USB 2.0/1.1 Connectors

The motherboard is equipped with two USB 2.0/1.1 interfaces. These connectors allow to connect USB-compatible devices to the KISS Short.

Line-out / Line-in / Microphone Connector

These audio jacks (3.5 mm) allow to connect an external speaker/headphone set (Line-out), an external audio device (Line-in) and an external microphone (Mic-in).

Parallel Interface Connector

This connector is available as a 25-pin D-SUB socket. The LPT parallel interface supports different modes: SPP, EPP and ECP.

It is used for connecting an external printer and can also be used for other external devices which can be connected via the parallel port. Depending on the device, the manufacturer's instructions must be observed and the necessary software drivers installed.

External Interfaces of the installed SBC



For detailed information refer to the user's manual of the ePCI-101 SBC. The user's manual of the SBC can be downloaded from our web page www.kontron-EMEA.com. Search for the name of the SBC.

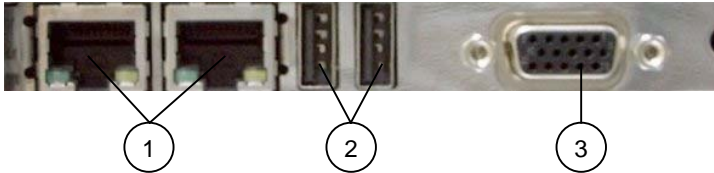

Fig. 14a: Rear side – Interfaces of the Kontron ePCI-101 SBC

- 1 2x Ethernet interface connector (RJ45)
- 2 2x USB 2.0/1.1 interface connector
- 3 VGA interface connector

Ethernet Interface Connectors

The KISS Short is equipped with two LAN connectors. These interface connectors are provided as RJ45 sockets with integrated LEDs and supports a data transfer rate of 10/100 Mbps.

USB Interface Connectors

KISS Short is equipped with two USB interfaces at the rear side. These connectors allow you to connect different USB-compatible devices to the device.

VGA Interface Connector

An external (analog) monitor can be plugged into this interface which is provided as a 15-pin D-SUB socket.



The ePCI-101 SBC supports two COM interfaces (on-board):

- COM1 as RS232
- COM2 as RS232/RS422/RS485 configurable.

Power Supply Unit

The power supply unit (PSU) is placed on the rear side of the unit. The PSU supports both 115V and 230V mains voltage.

For information about the power supply unit and the supply voltage of your system, refer to the type label attached to the right side of the device.



Before connecting the KISS Short to the power source, make sure that the voltage selector switch is adjusted to the available main voltage (115V or 230V).

The voltage of the power source must correspond to the voltage value on the type label.



Fig. 15: Voltage selector switch on the rear side

- 1 Warning label for adjusting the voltage selector switch
- 2 Voltage selector switch set to 230V (factory setting)
- 3 On/Off switch of the PSU

Fan Slide-In Module and Temperature Sensors

The two fans of the system are firmly mounted in a user friendly, exchangeable fan slide-in module (hot swap). The fan slide-in module is installed in the fan case located at the front side of the system.

The systems fans are temperature-controlled via the temperature sensors which are built in the system. Thus sufficient airflow is ensured for an optimal, active cooling of the system.



The operation of the KISS Short is permitted only with a functional fan slide-in module (refer to the “Replacing the System’s Fans” section).

Defective components may be replaced only by Kontron original spare parts.

❑ part number of the fan slide-in module: 0-0084-3604

The temperature conditions of the system (dependent on the ambient temperature and the system load) are acquired by two temperature sensors. One of the temperature sensors is attached in the rear range of the system (air exhaust openings) and the second one is attached laterally, in the middle range.

Side View

Three M4 metric tapped holes are available at the left and right side of the unit. These can be used in order to attach slide rails (not included in the scope of delivery) to the KISS Short (for system installation into a 19” industrial cabinet). Refer to the “Slide Rails (Option)” chapter.

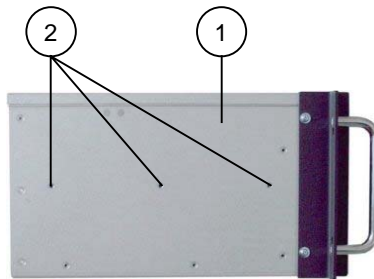

Fig. 16: Tapped M4 metric holes to attach a telescope rail

- | | | | |
|---|-----------------------------|---|---|
| 1 | Side view of the KISS Short | 2 | 3x tapped M4 metric holes (on both sides) |
|---|-----------------------------|---|---|

Integrated Motherboard / SBC

Depending on the ordered system configuration, your KISS Short accommodates either a motherboard or a SBC (Single Board Computer).



Refer to the information and technical data in the supplied user manual of the motherboard or SBC.

The user's manual of the installed board can be downloaded from our web page www.kontron-EMEA.com. Search for the name of the installed CPU board.



Depending on the ordered KISS Short hardware configuration you can expand your system with AGP/PCI expansion cards (half size).

To expand your system with expansion cards, please observe the power consumption specification specified in the “Main Specifications” chapter and that every additional card does not exceed 25 W power consumption.

System	Part Number	Installed Board	Available Expansion Slots
KISS Short	2-A0E1-0000	ePCI-101 SBC	9x PCI, 32 bit @ 33 MHz
KISS Short	2-A0E2-0000	886LCD-M/Flex Motherboard	1x AGP x4 3x PCI, 32 bit @33 MHz

Backplane (for Configuration with SBC)



To expand your system with additional cards, please observe the power consumption specification specified in the “Main Specifications” chapter and that every additional card does not exceed 25 W power consumption.

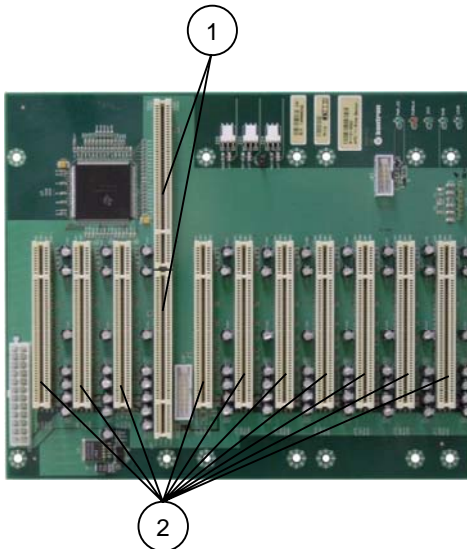

Maximal supported Bus speeds

- 1 1x PICMG 1.2 CPU-slot (half size)
- 2 10x 32 bit @ 33 MHz PCI-slot, 5 V keying

Fig. 17: Backplane (for System configuration with ePCI-101 SBC)

Assembly, Disassembly

Attaching the Rubber Feet

The rubber feet can be used for the desktop version of the system. Please follow these steps to attach the rubber feet to the bottom side of the chassis:



Before attempting to mount the rubber feet, the system must be powered-down and the power cord has to be disconnected from the power source.

1. Make sure that all cards are secured into the unit and that the system cover is installed and secured.
2. Turn the system upside down.
3. Remove the protect foil from the delivered self adhesive rubber feet.
4. Attach the self adhesive rubber feet to the bottom side of the chassis.

Removing the Drive Locking Screws

Before you start-up the system for the first time (before mounting/mounting into an industrial cabinet) open the system as described in the “Accessing Internal Components” section and remove the drive locking screws.

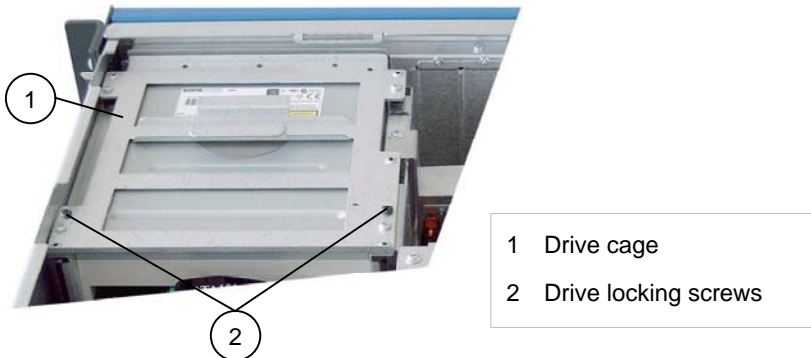

Fig. 18: KISS-Short drive cage with drive locking screws

Accessing Internal Components

This section contains important information that you must read before accessing the internal components. You must follow these procedures properly when handling any boards or replacing the fan slide-in module.

Installing/Removing the Expansion Cards

Please consider following instruction when you install (or remove) expansion cards.



Caution:

**Energy hazards > 240 VA are present inside the chassis!!!
Only qualified personnel and/or by Kontron Embedded
Computer authorized persons are permitted to work inside
the system or handling expansion cards!!!!**

The installation and removal of expansion cards have to be carried-out only by qualified specialist personnel in accordance with the description in this manual.

Before removing the cover to gain access to the internal components, the system must be powered-down and the power cord has to be disconnected from the power source.

To expand your system with expansion cards, please observe the power consumption specification specified in the "Main Specifications" chapter and that each additional card does not exceed 25 W power consumption.



Please observe the safety instruction for handling assemblies with static sensitive device.

Failure to take heed of this warning instruction can result in damage to the device.



Please consult the documentation provided by the manufacturer of the expansion card for instructions before attempting to install/remove an expansion card into/from the KISS Short.

To install or remove an expansion card, perform the following steps:

1. Turn off all power sources. Disconnect the power cord from power source.
2. Loosen the captive knurled screws on the rear side of the unit that secure the cover.



Fig. 19: Loosen the captive knurled screws

3. Lift the cover away.

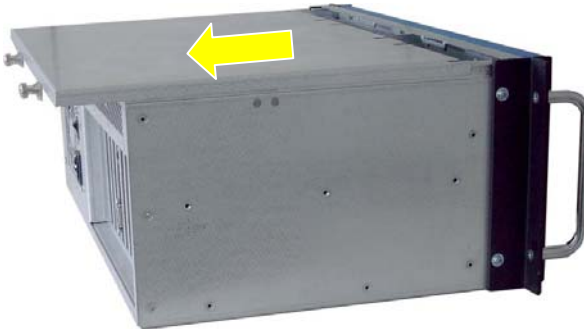

Fig. 19a: Removing the device cover



Fig. 19b: KISS Short without cover

4. To remove the card holder loosen the screw of the card holder (1). Slide the card hold-down bracket to right (2), to pull it out from the two laterally located bolts. Lift the card hold-down bracket away (3). Retain the card hold-down bracket and the screw for later use.

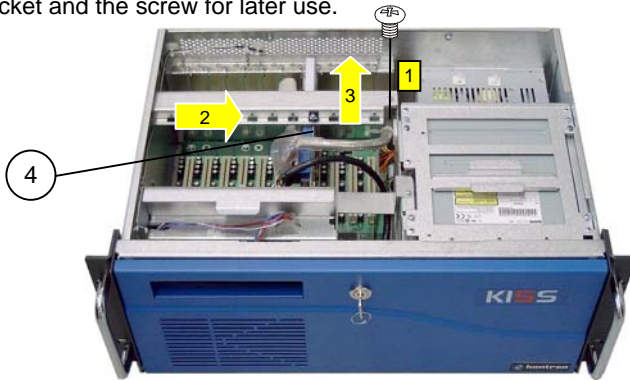

Fig. 20: Removing the fastening screw the card hold-down bracket



Fig. 21: Bolts and fastening point for the card hold-down bracket

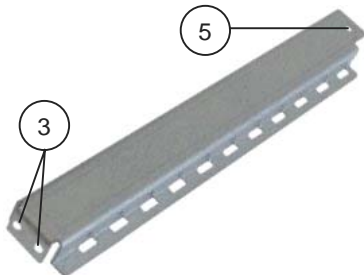

Fig. 22: Card hold-down bracket

Legend for figures: 20, 21 and 22:

- 1 Bolts for the card hold-down bracket
- 2 Threaded bolt
- 3 Locating holes
- 4 PCB holder
- 5 Hole for the fastening screw

5. Put/pull the expansion card into/or out from the expansion card slot of the backplane/motherboard and fasten the mounting bracket of the expansion card/filler bracket to the rear slot of the device.
6. Reinstall the card holder and secure it using the retaining screw (see fig. 20).
7. The PCP holder has to be installed into the appropriate hole of the card hold-down bracket by means of the provided screw, if necessary. Fix the upper edge of the expansion card into the slot of the PCB holder (height adjustable). Thus the card is firmly kept in place during high mechanical load (shock and vibrations).
8. Close the KISS Short and secure the cover with the captive knurled screws.



Please consult the documentation provided by the manufacturer of the expansion card for instructions before attempting to install/remove an expansion card into/from the system.

Instruction for Installation in a 19” Cabinet

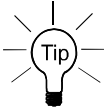

Expansion card installation should be performed before installing the KISS Short into an industrial cabinet or into a control panel. Refer to the “Accessing Internal Components” section.

Before closing the industrial cabinet, you have to connect the peripheral devices to the system interfaces. Refer to the “Interfaces on the Rear Side” subsection for the detailed description of the interfaces.



Important Instructions!

The KISS Short has to be installed only by trained and qualified personal.

The KISS Short should be installed into a 19"-industrial cabinet with mounting rails.

Ensure there is sufficient air circulation around the device when installing the KISS Short.

The openings for air intake and exhaust on the device must not be obstructed.

Leave at least 5 cm (approx. 2".) of free space in front and behind the unit to prevent the device from possibly overheating!



The 19" industrial cabinet must stand firmly in place. You can improve its stability by placing the components into it from the bottom up. Heavy components should be placed down below.

If further stabilization is necessary, then bolt the 19" industrial cabinet to the floor or anchor it on the wall.

The voltage feeds must not be overloaded. Adjust the cabling and the external overcharge protection to correspond with the electrical data indicated on the type label.

The type label is located on right side of the unit.

Starting Up

Power Cord Connection

The AC power plug is located on the rear side of the KISS Short.



Before connecting the KISS Short to the power source, make sure that the voltage selector switch is adjusted to the available main voltage (115V or 230V).

The voltage of the power source must correspond to the voltage value on the type label.

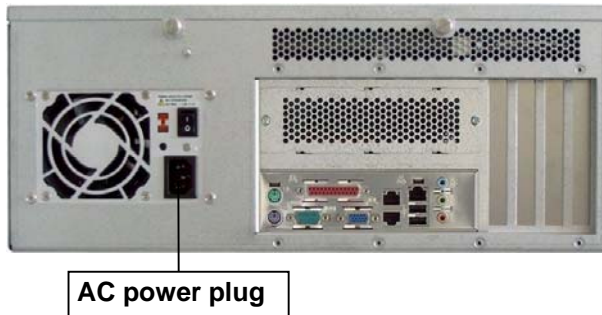

Fig. 23: AC Power connection (version with motherboard)

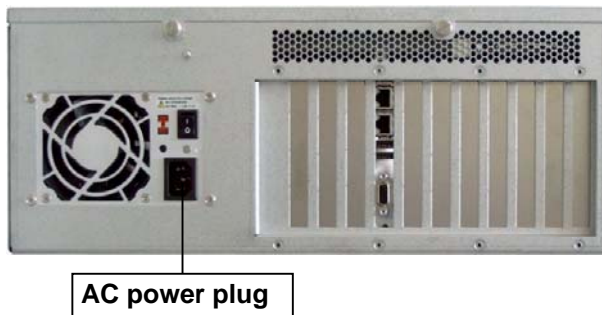

Fig. 23a: AC Power connection (version with SBC)

1. Make sure that the voltage selector switch is adjusted to the available main voltage (115V or 230V). The voltage of the power source must correspond to the voltage value on the type label.
2. Connect the supplied AC power cord into the system AC power plug (see *fig. 23 respectively 23a*).
3. Connect the other end of the AC power cord into a corresponding outlet.



Use the power cord suitable for the power supply in your country.

Do not remove or alter the grounding prong on the power cord. In situations where a two-slot receptacle is present, have it replaced with a properly grounded three-prong grounding type receptacle.

Operating System and Hardware Components Drivers

The KISS Short can optionally be supplied with or without a pre- installed operating system.

If you have ordered your KISS Short with a pre- installed operating system, all drivers are installed, corresponding to the ordered computer configuration (optional hardware components). Your computer is fully functional, when you switch it on for the first time.

If you have ordered your KISS Short without pre- installed operating system, you have to install the operating system and the corresponding drivers for the ordered computer configuration (optional hardware components).



The needed drivers can be downloaded from our web page: www.kontron_EMEA.com. Search for the product name.



Consider the manufacturer specifications of the operating system and the integrated hardware components.

Maintenance and Prevention

Kontron Embedded Computers systems require minimal maintenance and care to keep them operating correctly.

- Occasionally wipe the system with a soft dry cloth.
- You should only remove persistent dirt by use of a soft, slightly damp cloth (use only a mild detergent).
- Clean the air filter mats regularly (refer to the “Cleaning the Filter Mat” section).

Replacing the System's Fans



The operation of the KISS Short is permitted only with a functional fan slide-in module.

Defective components may be replaced only by Kontron original spare parts.

□ part number of the fan slide-in module: 0-0084-3604



Important Instructions!

The fan slide-in module is changeable while the KISS Short is powered-up. This maintenance may only be carried out by qualified personnel familiar with the associated dangers.

To replace fan slide-in module, proceed as follows:

1. Open the unit as described in the "Accessing Internal Components" section, step 2-3. Pull out the device cover only so far, to have access to the fan slide-in module.
2. Loosen the captive knurled screw (*fig. 24, pos. 4*). Use the handle (*fig. 24, 24a, pos. 2*) of the fan slide-in module and pull it out from the fan case (*fig. 24c, pos. 9*).

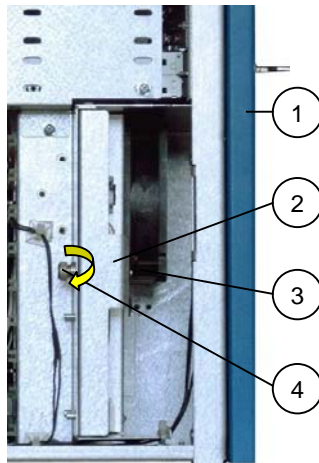

Fig. 24: KISS Short with fan slide-in module

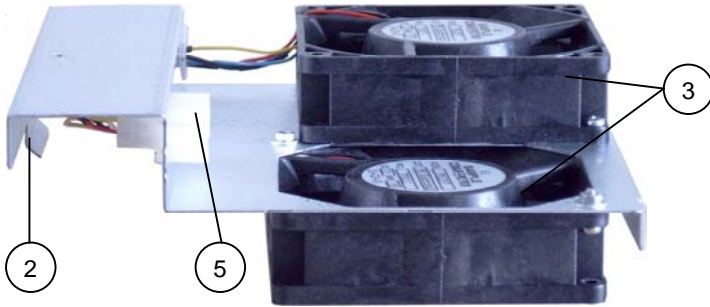

Fig. 24a: Side view of the fan slide-in module

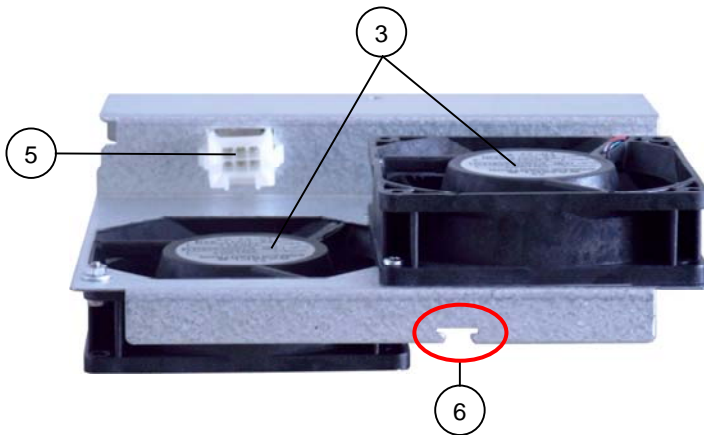

Fig. 24b: Bottom view of the fan slide-in module

Legend for figures: 24, 24a, 24b and 24c

- | | |
|--|--|
| 1 Front access panel of the system | 6 Centering slot on the bottom side of the fan slide-in module |
| 2 Handle of the fan slide-in module | 7 Socket in the fan case for fan control |
| 3 2x system fan (temperature controlled, independently controlled) | 8 Centering angle |
| 4 Captive knurled screw | 9 Fan case |
| 5 Plug for fan control | |

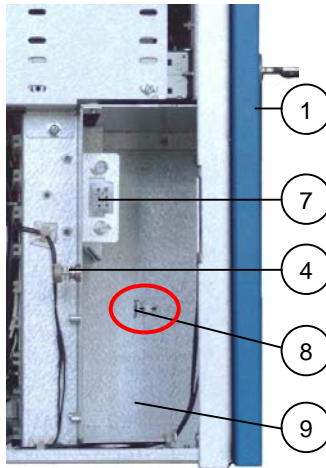
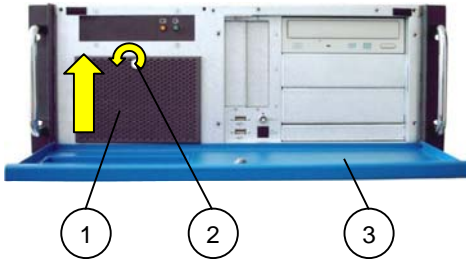

Fig. 24c: Fan case of the KISS Short without fan slide-in module

3. Replace the fan slide-in module with a new functional module. Push the fan slide-in module carefully into the fan case socket connector, by aligning the centering angle (*fig. 24c, pos. 8*) to the centering slot (*fig. 24b, pos. 6*).
4. Secure the fan slide-in module with the captive knurled screw.
5. Close the KISS Short and secure the cover with the captive knurled screws.

Cleaning the Filter Mat

The filter mat is inserted in the filter mat holder at the front side of the system. Cleaning frequency of the filter mat will depend on the operating environment. If the environment is extremely dusty, clean the filter mat more often. The filter mat can be changed even if the system is powered-up.



- 1 Filter mat holder
- 2 Fastening screw of the filter mat holder
- 3 Front access panel

Fig. 25: Location of the filter mat

To replace or clean the air filter mat, proceed as follows:

1. Open the front access panel.
2. Loosen the knurled screw that secure the filter mat holder with the air filter mat to the chassis.
3. Pull out the filter mat holder into the marked direction.
4. Remove the dirty air filter mat.
5. To clean the filter mat:
 - Rinse in water (up to approx. 40°C; you may add mild-duty commercial detergent).
 - It is also possible to beat it out, vacuum it or blast it with warm compressed air.
 - If the filter is soiled with greasy dust, you should rinse it with warm water with degreaser added. Do not clean the filter mat with a piercing jet of water or wring it out.
6. After cleaning and drying the filter mat, replace it into the filter mat holder, Replace the filter mat holder to the front side of the chassis (see fig. 26, pos. 3 and fig. 26a, pos. 4).
7. Tighten the screw to secure the filter mat holder to the chassis.



When inserting the filter mat, ensure that the denser side of the mat is facing the fans.



Defective components may be replaced only by Kontron original spare parts.

□ part number of the filter mat: 0-0084-2953

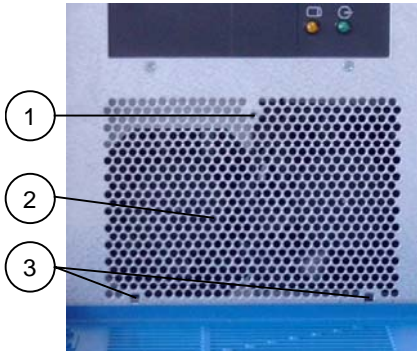

Fig. 26: Location for filter mat holder

Legend for figures: 26, 26a and 26b:

- 1 Threaded M4 metric stud
- 2 Air intake openings
- 3 Centering holes for the filter mat holder
- 4 Locking tabs
- 5 Inserted filter mat
- 6 Fastening screw of the filter mat holder
- 7 Filter mat holder

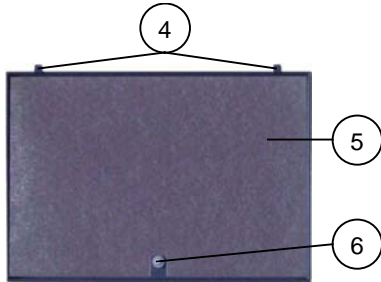

Fig. 26a: Filter mat holder with filter mat

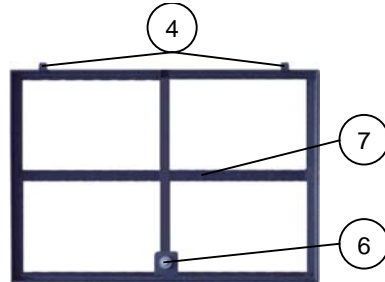

Fig. 26b: Filter mat holder without filter mat

Replacing the Lithium Battery

The installed motherboard or SBC of your system is equipped with a lithium battery. To replace the battery, please proceed as follows:

1. Open the unit as described in the “Installing/Removing the Expansion Cards” chapter (step 1-4).
2. If your system is expanded with expansion cards, please remove at first the cards and the corresponding data cables, to have access to the lithium battery.
3. Remove the battery by pressing outwards the ejector spring.
4. Place the new battery into the socket.
5. Make sure that you insert the battery the right way around. The plus pole must be on the top!
6. The lithium battery must be replaced with an identical battery or a battery type recommended by Kontron Embedded Computers.
7. Reinstall the removed expansion cards and reconnect the removed data cable.
8. Close the Unit as described in chapter “Installing/Removing the Expansion Cards” (step 5-8).



Do not dispose of lithium batteries in general trash collection. Dispose of the battery according to the local regulations dealing with the disposal of these special materials, (e.g. to the collecting points for dispose of batteries).

Slide Rails (Option)

Kontron offers slide rails for the installation of the KISS Short into a 19" industrial cabinet. These can be ordered under:

"Slide rails" - Set No.: 3-A260-0244.

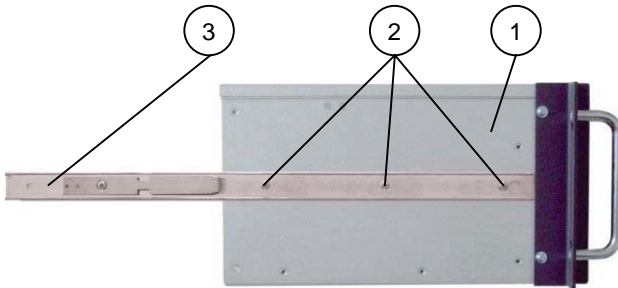

Fig. 27: Attaching the inner side of the slide rail

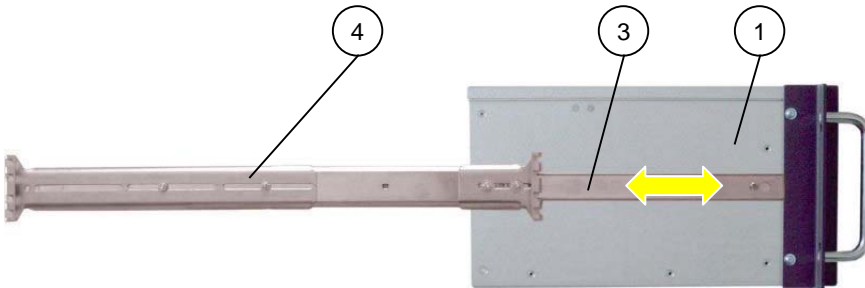

Fig. 27a: Kiss-Plattform with slide rail

Legend for figures: 27 and 27a:

- | | | | |
|---|---|---|--|
| 1 | Side view of the KISS Short | 3 | Slide rail inner part |
| 2 | 3x M4x6 rounded head screw
(per each side of the unit) | 4 | Slide rail outer part [with
brackets (short at the front, long
at the rear)] |



Please observe, that only the specified M4x6 screws may be used for the attachment of telescope rails to the KISS Short.

Slide Rails Accessories and Assembling

The "Slide rails" set consists of the following elements:

- ❑ One pair of slide rails
- ❑ One pair of short front brackets (with screws and washers)
- ❑ One pair of long rear brackets (with screws and washers)
- ❑ 2 x bar nut kits
- ❑ 8 x M4x 6 nuts

For assembling refer to *fig. 28*.

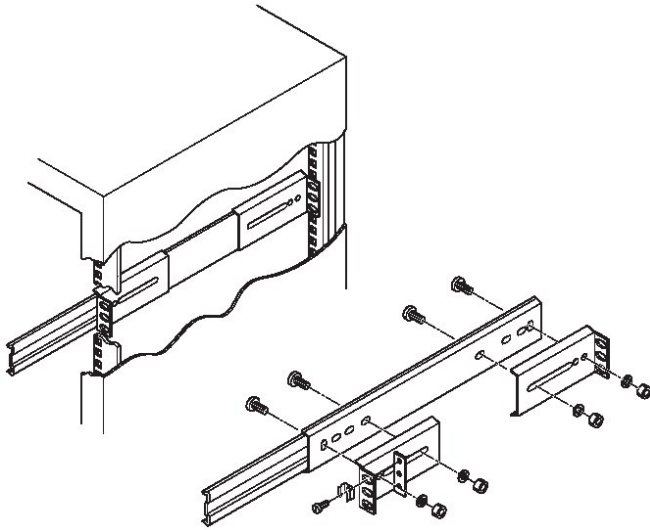

Fig. 28: Assembling of the "Slide-rails" set



Short brackets are usually used at the front of the chassis and long brackets at the rear.

Device Mounting into an Industrial Cabinet (with Slide Rails)

1. Ensure that the industrial cabinet sides are parallel and that the KISS Short chassis sides are parallel and square to the industrial cabinet.
2. Using mounting kits and brackets, mount brackets to the outer part of the slide rails (see *fig. 27a, pos. 4*). Screw the back brackets on loosely.
3. Install the slide rails into the industrial cabinet.
4. Mount the inner part (see *fig. 27a, pos. 3*) of the slide rails to the chassis.
5. Insert the KISS Short into the industrial cabinet.
6. Check for even and smooth movement of the chassis.
7. If binding occurs, or slide movement is not satisfactory:
 - Loosen screws on rear mount brackets and adjust brackets.
 - Loosen screws on the chassis side.
 - Cycle the unit a few times.
 - If movement has improved tighten off screws and cycle again.

Main Specifications

Processor	Intel® Pentium® M 1.8 GHz or Intel® Celeron® M 1.3 GHz
Lithium-Battery	Type: CR2032; 3.0 V; 0.22Ah; LIXING
Drive bays at the front side & internal	3x 5.25", outside accessible (horizontal position) 1x 3.5" (internal HDD) or 1x Slim
External Interfaces at the rear side	for systems with SBC (ePCI-101): 2x Ethernet interface (10/100 Mbps) 2x USB (2.0/1.1) interface 1x VGA interface 2x serial interface (on-board [1x COM1 (RS232)] 1x COM2 (RS232/RS422/RS485)]) for systems with motherboard (886LCD-M/Flex): 1x PS/2 mouse 1x PS/2 keyboard 1x serial interface (RS232 only) 1x LPT 1x VGA 3x Ethernet (RJ45) 2x USB (2.0/1.1) 1x Microphone (pink) 1x Line-out (green) 1x Line-in (blue)
External Interfaces at the front side	2x USB (2.0/1.1)
Operating elements at the front side	1x ATX Power button 1x Reset button
Operating element at the rear side	1x PSU switch 1x Voltage selector switch
LED-indicators at the front side	1x Power LED 1x HDD activity LED
Expansion slots at the rear side	for systems with SBC: 1x PICMG 1.2 (half size) for SBC up to max. 9x PCI slot, 32 bit @ 33 MHz for systems with motherboard: 1x AGP x4-slot 3x PCI slot 32 bit @ 33 MHz
AC power plug	at the rear side

Power Specification (max. power value for additional customised applications)	Total power of all additional customised applications	max. 170 W
	Power consumption pro slot (PCI)	max. 25 W
	Power consumption at +3.3 VDC and +5 VDC (combined)	max. 115 W

Electrical Specifications

KISS Short Version	Integrated PSU	Input
2-A0E1-0000	ATX 275 W	115/230 V 60/50 Hz max. 3 A
2-A0E2-0000	ATX 275 W	115/230 V 60/50 Hz max. 3 A

Mechanical Specifications

Dimension	
Height	4HE (177 mm)
Width	Front: 19"; Chassis: 430 mm (16.929")
Depth	Chassis: 317 mm (12.48")
Weight	Approx. 13 kg (28.66 lbs); (without packaging)
Chassis	Sheet metal steel zinc plated, black Steel front panel, blue

Environmental Specifications

Thermal Management	1x power supply fan (temperature controlled) 2x system fans (temperature controlled)
Operating Temperature / relative Humidity	0 ... +50°C / 5 - 90 % not condensing (32 ... 122 °F / 5 - 90% not condensing)
Storage / Transit Temp. / relative Humidity	-25 ... +70 °C / 0 - 95 % not condensing (-13 ... 158 °F / 5 - 95 % not condensing)
Operating Altitude	3,048 m (10,000 ft)
Storage / Transit Altitude	10,000 m (32,810 ft)
Operating Shock	5 G, 11 ms duration, half sine
Storage / Transit Shock	30 G, 11 ms duration, half sine
Operating Vibration	10 – 500 Hz, 0.5 G
Storage / Transit Vibration	10 – 500 Hz, 1.0 G
Acoustic Noise	<35 dB at 1 m in front of the system, full load

CE Directives and Standards

CE Directives	
Low Voltage Directive (Electrical Safety)	73/23/ECC
EMC Directive	89/336/ECC modified by 92/31/ECC
CE Marking	93/68/ECC

Electrical Safety	Standards
EUROPE	EN 60950-1: 2001
U.S.A.	to meet UL 60950-1: 2003, First Edition

EMC	Standards
EUROPE	Generic emission standard for industrial environments (Emission): EN 61000-6-4: 2001 Generic standards - Immunity for industrial environments (Immunity): EN 61000-6-2: 2001
U.S.A.	FCC 47 CFR Part 15, Class A

Standard Interfaces - Pin Assignments

Low-active are indicated by a minus sign.

COM1 / COM2 (RS232)

Pin	Signal Name	9-pin D-SUB Plug
1	DCD (Data Carrier Detect)	
2	RXD (Receive Data)	
3	TXD (Transmit Data)	
4	DTR (Data Terminal Ready)	
5	GND (Signal Ground)	
6	DSR (Data Set Ready)	
7	RTS (Request to Send)	
8	CTS (Clear to Send)	
9	RI (Ring Indicator)	

Parallel Port

Pin	Signal Name	25-pin D-SUB Socket
1	-STROBE	<p>The diagram shows a vertical 25-pin D-SUB socket. The pins are arranged in two columns of 12 pins each, with a gap between the two columns. Pin 1 is at the top left, pin 13 is at the bottom left, pin 14 is at the top right, and pin 25 is at the bottom right. There are also two hexagonal pins at the top and bottom center of the socket.</p>
2	DATA0	
3	DATA1	
4	DATA2	
5	DATA3	
6	DATA4	
7	DATA5	
8	DATA6	
9	DATA7	
10	-ACKN	
11	BUSY	
12	PE	
13	SELECT	
14	-AUTOFD	
15	-ERROR	
16	-INIT	
17	-SLCTIN	
18-25	GND	

PS/2 Mouse Connector

Pin	Signal Name	6-pin Mini-DIN Socket
1	Mouse data	
2	N.C.	
3	GND	
4	+5 V	
5	Mouse clock	
6	N.C.	

PS/2 Keyboard Connector

Pin	Signal Name	6-pin Mini-DIN Socket
1	Keyboard data	
2	N.C.	
3	GND	
4	+5 V	
5	Keyboard clock	
6	N.C.	

VGA Port

Pin	Signal Name	15-pin D-SUB Socket (female)
1	Analog red output	
2	Analog green output	
3	Analog blue output	
4	N.C.	
5-8	GND	
9	+5 V (DDC)	
10	GND	
11	N.C.	
12	SDA (DDC)	
13	TTL HSync	
14	TTL VSync	
15	SCL (DDC)	

USB Port

Pin	Signal Name	4-pin USB Socket Type A Version 2.0/1.1
1	VCC	
2	Data-	
3	Data+	
4	GND	

Technical Support

For technical support, please contact our Technical Support department.

German headquarter Hotline:

Tel: +49 (0)9461 950-104

Fax: +49 (0)9461 950-200

E-mail: support@kontron.com

Make sure you have the following information on hand when you call:

- the unit part id number (P/No #),
- and the serial number (S/No #) of the unit (provide the serial number found on the type label, placed on the right side of the system).

Be ready to explain the nature of your problem to the service technician.

If you have questions about Kontron Embedded Computers or our products and services, you may reach us at the aforementioned numbers, or at :

www.kontron-EMEA.com or by writing to:

Kontron Embedded Computers GmbH

Oskar-von-Miller-Str. 1

85386 Eching

Germany

Returning Defective Merchandise

Before returning any merchandise, please:

1. Contact our Service and request an RMA number (Return Material Authorization) by :
Fax: (+49) 8165-77 412
E-mail: service@kontron.com
2. Make sure that you receive an RMA number from Kontron Embedded Computers-Service before returning any merchandise. Clearly write or mark this number on the outside of the package you are returning.
3. Describe the device failure behavior.
4. When returning goods, include the name and telephone number of a person whom we can contact for further explanations if necessary. Where applicable, always include all duty papers and invoice(s) associated with the item(s) in question.
5. When returning a unit.
 - Ensure that the unit is properly packed in the original box.
 - Include a copy of the RMA form.