



# PMC240

## Dual Channel Gigabit Ethernet Controller

Manual ID: 25270, Rev. Index 01  
June 2002



The product described in this manual is in compliance with all applied CE standards.



## Revision History

Manual/Product Title:		PMC240	
Manual ID Number:		25270	
Rev. Index	Brief Description of Changes	Board Index	Date of Issue
01	Initial Issue	00	June 2002

## Imprint

Copyright © 2002 PEP Modular Computers GmbH. All rights reserved. This manual may not be copied, photocopied, reproduced, translated or converted to any electronic or machine-readable form in whole or in part without prior written approval of PEP Modular Computers GmbH.



**DISCLAIMER:**

PEP Modular Computers GmbH rejects any liability for the correctness and completeness of this manual as well as its suitability for any particular purpose.

This manual was realized by: **TPD/Engineering, PEP Modular Computers GmbH.**



## Table of Contents

<i>Revision History</i> .....	<i>ii</i>
<i>Imprint</i> .....	<i>ii</i>
<i>Table of Contents</i> .....	<i>iii</i>
<i>List of Tables</i> .....	<i>vii</i>
<i>List of Figures</i> .....	<i>ix</i>
<i>Proprietary Note</i> .....	<i>xi</i>
<i>Trademarks</i> .....	<i>xi</i>
<i>Environmental Protection Statement</i> .....	<i>xi</i>
<i>Explanation of Symbols</i> .....	<i>xii</i>
<i>For Your Safety</i> .....	<i>xiii</i>
<i>High Voltage Safety Instructions</i> .....	<i>xiii</i>
<i>Special Handling and Unpacking Instructions</i> .....	<i>xiii</i>
<i>General Instructions on Usage</i> .....	<i>xiv</i>
<i>Two Year Warranty</i> .....	<i>xv</i>

# Chapter **1**

<i>1. Introduction</i> .....	<i>1 - 3</i>
<i>1.1 System Overview</i> .....	<i>1 - 3</i>
<i>1.2 Product Overview</i> .....	<i>1 - 4</i>
<i>1.3 Board Overview</i> .....	<i>1 - 5</i>
<i>1.3.1 Board Introduction</i> .....	<i>1 - 5</i>
<i>1.3.2 Board Specific Information</i> .....	<i>1 - 5</i>
<i>1.3.3 DRIVER Software</i> .....	<i>1 - 6</i>
<i>1.4 Board Diagrams</i> .....	<i>1 - 6</i>
<i>1.4.1 System Level Interfacing</i> .....	<i>1 - 6</i>
<i>1.4.2 Front Panels</i> .....	<i>1 - 10</i>
<i>1.4.3 Board Layouts</i> .....	<i>1 - 10</i>
<i>1.5 Technical Specifications</i> .....	<i>1 - 13</i>
<i>1.6 Applied Standards</i> .....	<i>1 - 15</i>
<i>1.7 Related Publications</i> .....	<i>1 - 15</i>



## Chapter 2

2.	<i>Functional Description</i>	2 - 3
2.1	<i>General Information</i>	2 - 3
2.1.1	<i>Signal Conditioning</i>	2 - 3
2.1.2	<i>Gigabit Ethernet Controller</i>	2 - 4
2.1.3	<i>System Interfaces</i>	2 - 4
2.1.4	<i>On Board Memory</i>	2 - 4
2.1.5	<i>Monitor and Control</i>	2 - 4
2.1.6	<i>Software</i>	2 - 4
2.2	<i>Board-Level Interfacing Diagram</i>	2 - 5
2.3	<i>System Interfaces</i>	2 - 7
2.3.1	<i>Ethernet Wire Cabling Interface</i>	2 - 7
2.3.2	<i>Ethernet Fiber Optic Interface</i>	2 - 8
2.3.3	<i>PCI / PCI-X Interface</i>	2 - 8
2.4	<i>Onboard Memory</i>	2 - 10
2.4.1	<i>Configuration EEPROM</i>	2 - 10
2.4.2	<i>Flash Memory</i>	2 - 10
2.5	<i>Monitor and Control (M/C)</i>	2 - 10
2.5.1	<i>Pre-Operation M/C</i>	2 - 10
2.5.2	<i>Operation M/C</i>	2 - 10

## Chapter 3

3.	<i>Installation</i>	3 - 3
3.1	<i>Hardware Installation</i>	3 - 3
3.1.1	<i>Safety Requirements</i>	3 - 3
3.1.2	<i>Installation Procedures</i>	3 - 4
3.1.3	<i>Removal Procedures</i>	3 - 6
3.2	<i>Software Installation</i>	3 - 6



---

*Chapter* **4**

4. *Configuration* ..... 4 - 3



This page was intentionally left blank.





## List of Tables

1-1	<i>PMC240 Product Overview</i> .....	1 - 4
1-2	<i>PMC240 Main Specifications</i> .....	1 - 13
1-3	<i>PMC240 Power Consumption</i> .....	1 - 14
1-4	<i>Applied Standards</i> .....	1 - 15
1-5	<i>Related Publications</i> .....	1 - 15
2-1	<i>Pinouts of CON1 and CON5 Based on the Implementation</i> .....	2 - 7
2-2	<i>Pinouts of CON3, CON4, and CON2</i> .....	2 - 9



---

This page was intentionally left blank.





## List of Figures

1-1	<i>System Level Interfacing with PMC Carrier Board</i> .....	1 - 7
1-2	<i>System Level Interfacing with CPU Board</i> .....	1 - 9
1-3	<i>PMC240 Front Panel Standard Variant Views</i> .....	1 - 10
1-4	<i>PMC240 Variant A</i> .....	1 - 11
1-5	<i>PMC240 Variant B</i> .....	1 - 11
1-6	<i>PMC240 Variant C</i> .....	1 - 12
1-7	<i>PMC240 Variant D</i> .....	1 - 12
2-1	<i>PMC240 Board Level Interfacing</i> .....	2 - 6
2-2	<i>CON1 and CON5 Connectors</i> .....	2 - 7
2-3	<i>CON6 and CON7 Fiber Optic Receptacles</i> .....	2 - 8
2-4	<i>Pinouts of CON3, CON4, and CON2</i> .....	2 - 8
3-1	<i>Installation / Removal Diagrams</i> .....	3 - 5



---

This page was intentionally left blank.



---

## Proprietary Note

This document contains information proprietary to *PEP Modular Computers*. It may not be copied or transmitted by any means, disclosed to others, or stored in any retrieval system or media without the prior written consent of *PEP Modular Computers GmbH* or one of its authorized agents.

The information contained in this document is, to the best of our knowledge, entirely correct. However, *PEP Modular Computers* cannot accept liability for any inaccuracies or the consequences thereof, or for any liability arising from the use or application of any circuit, product, or example shown in this document.

*PEP Modular Computers* reserves the right to change, modify, or improve this document or the product described herein, as seen fit by *PEP Modular Computers* without further notice.

## Trademarks

*PEP Modular Computers*, the PEP logo and, if occurring in this manual, “CXM” are trade marks owned by *PEP Modular Computers GmbH*, Kaufbeuren (Germany). In addition, this document may include names, company logos, and trademarks which are registered trademarks and are, therefore, proprietary to their respective owners.

## Environmental Protection Statement

This product has been manufactured to satisfy environmental protection requirements where possible. Many of the components used (structural parts, printed circuit boards, connectors, batteries, etc.) are capable of being recycled.

Final disposition of this product after its service life must be accomplished in accordance with applicable country, state, or local laws or regulations.



## Explanation of Symbols



### ***CE Conformity***

This symbol indicates that the product described in this manual is in compliance with all applied CE standards. Please refer also to the section “Applied Standards” in this manual.



### ***Caution, Electric Shock!***

This symbol and title warn of hazards due to electrical shocks (> 60V) when touching products or parts of them. Failure to observe the precautions indicated and/or prescribed by the law may endanger your life/health and/or result in damage to your material.

Please refer also to the section “High Voltage Safety Instructions” on the following page.



### ***Warning, ESD Sensitive Device!***

This symbol and title inform that electronic boards and their components are sensitive to static electricity. Therefore, care must be taken during all handling operations and inspections of this product, in order to ensure product integrity at all times.

Please read also the section “Special Handling and Unpacking Instructions” on the following page.



### ***Warning!***

This symbol and title emphasize points which, if not fully understood and taken into consideration by the reader, may endanger your health and/or result in damage to your material.



### ***Note...***

This symbol and title emphasize aspects the reader should read through carefully for his or her own advantage.



## For Your Safety

Your new *PEP* product was developed and tested carefully to provide all features necessary to ensure its compliance with electrical safety requirements. It was also designed for a long fault-free life. However, the life expectancy of your product can be drastically reduced by improper treatment during unpacking and installation. Therefore, in the interest of your own safety and of the correct operation of your new *PEP* product, you are requested to conform with the following guidelines.

### High Voltage Safety Instructions



#### **Warning!**

All operations on this device must be carried out by sufficiently skilled personnel only.



#### **Caution, Electric Shock!**

Before installing your new *PEP* product into a system always ensure that your mains power is switched off. This applies also to the installation of piggybacks.

Serious electrical shock hazards can exist during all installation, repair and maintenance operations with this product. Therefore, always unplug the power cable and any other cables which provide external voltages before performing work.

### Special Handling and Unpacking Instructions



#### **ESD Sensitive Device!**

Electronic boards and their components are sensitive to static electricity. Therefore, care must be taken during all handling operations and inspections of this product, in order to ensure product integrity at all times.

Do not handle this product out of its protective enclosure while it is not used for operational purposes unless it is otherwise protected.

Whenever possible, unpack or pack this product only at EOS/ESD safe work stations. Where a safe work station is not guaranteed, it is important for the user to be electrically discharged before touching the product with his/her hands or tools. This is most easily done by touching a metal part of your system housing.

It is particularly important to observe standard anti-static precautions when changing piggybacks, ROM devices, jumper settings etc. If the product contains batteries for RTC or memory back-up, ensure that the board is not placed on conductive surfaces, including anti-static plastics or sponges. They can cause short circuits and damage the batteries or conductive circuits on the board.



---

## General Instructions on Usage

In order to maintain PEP's product warranty, this product must not be altered or modified in any way. Changes or modifications to the device, which are not explicitly approved by *PEP Modular Computers* and described in this manual or received from PEP Technical Support as a special handling instruction, will void your warranty.

This device should only be installed in or connected to systems that fulfill all necessary technical and specific environmental requirements. This applies also to the operational temperature range of the specific board version, which must not be exceeded. If batteries are present their temperature restrictions must be taken into account.

In performing all necessary installation and application operations, please follow only the instructions supplied by the present manual.

Keep all the original packaging material for future storage or warranty shipments. If it is necessary to store or ship the board please re-pack it as nearly as possible in the manner in which it was delivered.

Special care is necessary when handling or unpacking the product. Please, consult the special handling and unpacking instruction on the previous page of this manual.



## Two Year Warranty

*PEP Modular Computers* grants the original purchaser of PEP products a **TWO YEAR LIMITED HARDWARE WARRANTY** as described in the following. However, no other warranties that may be granted or implied by anyone on behalf of PEP are valid unless the consumer has the express written consent of *PEP Modular Computers*.

*PEP Modular Computers* warrants their own products, excluding software, to be free from manufacturing and material defects for a period of 24 consecutive months from the date of purchase. This warranty is not transferable nor extendible to cover any other users or long-term storage of the product. It does not cover products which have been modified, altered or repaired by any other party than *PEP Modular Computers* or their authorized agents. Furthermore, any product which has been, or is suspected of being damaged as a result of negligence, improper use, incorrect handling, servicing or maintenance, or which has been damaged as a result of excessive current/voltage or temperature, or which has had its serial number(s), any other markings or parts thereof altered, defaced or removed will also be excluded from this warranty.

If the customer's eligibility for warranty has not been voided, in the event of any claim, he may return the product at the earliest possible convenience to the original place of purchase, together with a copy of the original document of purchase, a full description of the application the product is used on and a description of the defect. Pack the product in such a way as to ensure safe transportation (see our safety instructions).

PEP provides for repair or replacement of any part, assembly or sub-assembly at their own discretion, or to refund the original cost of purchase, if appropriate. In the event of repair, refunding or replacement of any part, the ownership of the removed or replaced parts reverts to *PEP Modular Computers*, and the remaining part of the original guarantee, or any new guarantee to cover the repaired or replaced items, will be transferred to cover the new or repaired items. Any extensions to the original guarantee are considered gestures of goodwill, and will be defined in the "Repair Report" issued by PEP with the repaired or replaced item.

*PEP Modular Computers* will not accept liability for any further claims resulting directly or indirectly from any warranty claim, other than the above specified repair, replacement or refunding. In particular, all claims for damage to any system or process in which the product was employed, or any loss incurred as a result of the product not functioning at any given time, are excluded. The extent of *PEP Modular Computers* liability to the customer shall not exceed the original purchase price of the item for which the claim exists.

*PEP Modular Computers* issues no warranty or representation, either explicit or implicit, with respect to its products' reliability, fitness, quality, marketability or ability to fulfil any particular application or purpose. As a result, the products are sold "as is," and the responsibility to ensure their suitability for any given task remains that of the purchaser. In no event will PEP be liable for direct, indirect or consequential damages resulting from the use of our hardware or software products, or documentation, even if PEP were advised of the possibility of such claims prior to the purchase of the product or during any period since the date of its purchase.

Please remember that no *PEP Modular Computers* employee, dealer or agent is authorized to make any modification or addition to the above specified terms, either verbally or in any other form, written or electronically transmitted, without the company's consent.



This page was intentionally left blank.







---

*Chapter*

---

**1**

---

# Introduction

---



This page was intentionally left blank.





# 1. Introduction

## 1.1 System Overview

The CompactPCI PMC module described in this manual operates with the PCI bus architecture to support additional I/O and memory-mapped devices as required by various industrial applications. For detailed information concerning the CompactPCI standard, please consult the complete Peripheral Component Interconnect (PCI) and CompactPCI Specifications. For further information regarding these standards and their use, visit the homepage of the *PCI Industrial Computer Manufacturers Group (PICMG)*.

Many system relevant CompactPCI features that are specific to PEP Modular Computers CompactPCI systems may be found described in the PEP CompactPCI System Manual. Please refer to the section “Related Publications” at the end of this chapter for the relevant ordering information.

The CompactPCI System Manual includes the following information:

- Common information that is applicable to all system components, such as safety information, warranty conditions, standard connector pinouts etc.
- All the information necessary to combine PEP’s racks, boards, backplanes, power supply units and peripheral devices in a customized CompactPCI system, as well as configuration examples.
- Data on rack dimensions and configurations as well as information on mechanical and electrical rack characteristics.
- Information on the distinctive features of PEP CompactPCI boards, such as functionality, hot swap capability. In addition, an overview is given for all existing PEP CompactPCI boards with links to the relating data sheets.
- Generic information on the PEP CompactPCI backplanes, such as the slot assignment, PCB form factor, distinctive features, clocks, power supply connectors and signalling environment, as well as an overview of the PEP CompactPCI standard backplane family.
- Generic information on the PEP CompactPCI power supply units, such as the input/output characteristics, redundant operation and distinctive features, as well as an overview of the PEP CompactPCI standard power supply unit family.



## 1.2 Product Overview

The PMC240 Dual Channel Gigabit Ethernet Controller is a part of a comprehensive concept to provide CompactPCI system integrators with a complete range of CompactPCI communications products for high speed data networks. This concept ensures a maximum degree of system design flexibility thus allowing efficient and effective usage of available resources.

The basic function of this board is to provide applications with up to two high speed Ethernet interfaces per module and to support system expansion as required. The major components involved in this process are the Intel® chips: Intel 82546EB Dual Port Gigabit Ethernet Controller and the Intel 82545EM Single Port Gigabit Ethernet Controller.

Both controllers provide full support for 10Base-T, 100Base-TX, 1000Base-T, and 1000Base-SX operations. In addition to supporting the Ethernet functionality, they provide interfacing to the PCI-bus. Variant modules are available which provide a full spectrum of integration possibilities: single channel copper to dual channel fiber optic.

The following table provides a quick overview of the PMC240 module.

**Table 1-1: PMC240 Product Overview**

PMC240 FEATURES	DESCRIPTION
Ethernet Controller	<ul style="list-style-type: none"> <li>Fully compatible CMC / PMC module</li> <li>Single or dual channel Ethernet function (MAC and PHY / SERDES function layers integrated in chip)</li> <li>Designed for Plug and Play</li> </ul>
External Interfaces	Host: <ul style="list-style-type: none"> <li>PCI (2.2)</li> <li>PCI-X (1.0a)</li> </ul> Ethernet variants available: <ul style="list-style-type: none"> <li>single copper (RJ45 connector)</li> <li>dual copper (RJ45 connector)</li> <li>single copper, single fiber optic (RJ45 connector, SC multimode connector)</li> <li>dual fiber optic (SC multimode connector)</li> </ul>
Monitor and Control	<ul style="list-style-type: none"> <li>Link status LED's</li> <li>Ethernet driver software</li> </ul>



## 1.3 Board Overview

### 1.3.1 Board Introduction

The PMC240 Dual Channel Ethernet Controller is a CMC / PMC mezzanine card designed for use with compliant carrier boards or CPU boards which support PMC modules. This module incorporates a very flexible design which allows simple and easy integration of Ethernet functionality to any compliant system. As such, the PMC240 is an ideal solution for a very wide variety of application requirements: from simple starting systems which must use currently available resources to complex upgrade implementations employing newer technology.

The module itself may be equipped with either the single channel controller (Intel® 82545EM) or the dual channel controller (Intel® 82546EB). Except for the number of channels, the functionality provided by both controllers is essentially the same. The module supports either chip using the same board design. This concept reduces the solution expenditure while providing maximum performance and implementation flexibility.

Network interfacing is accomplished using either CAT5 UTP cabling for 10Base-T, 100Base-TX, 1000Base-T operation, or multimode fiber optic links for 1000Base-SX operation. For copper solutions, all MAC and PHY functions are integrated into the controller chips. Only galvanic isolation is performed externally. For fiber optic solutions, the controller chips also provide all MAC and PHY functions (including SERDES) except for the optical transceiver interface. This is accomplished using an external transceiver module for each channel which also includes the connectors to the optical links.

Host interfacing is provided by CMC / PMC compliant connectors and a single on-chip PCI interface which supports both the PCI 2.2 as well as PCI-X 1.0a specifications. Depending on application requirements, the PMC240 provides 32 or 64 bit data addressing and 33 / 66 MHz PCI or 66 / 133 MHz PCI-X bus operation. Whether single or dual channel operation, the controller chips represent only one electrical load to the PCI / PCI-X bus.

### 1.3.2 Board Specific Information

Specific board components involved in the Ethernet communications and data handling process are:

- Front panel connectors (dependent on variant):
  - Up to two RJ45 connectors
  - Up to two Magnetics modules for galvanic isolation (RJ45 front end)
  - Up to two Agilent HFBR-53A5VEM Fiber Optic Transceivers (with built-in connectors)
- Gigabit Ethernet controllers: (either)
  - One single port Intel® 82545EM Gigabit Ethernet Controller, or
  - One dual port Intel® 82546EB Dual Port Gigabit Ethernet Controller
- Three CMC / PMC compliant, 64 contact, male connectors (Pn1, Pn2, Pn3)
- Two linear voltage regulators
- Front panel LED's:
  - Four per channel with RJ45 copper front end
  - Two per channel with SC-type optical front end
- One EEPROM (Configuration EEPROM)
- Optionally, up to 512 kB of soldered Flash memory



## 1.3.3 DRIVER Software

The PMC240 is supplied with appropriate driver software which provides software interfacing to the carrier CPU or system master.

## 1.4 Board Diagrams

The following diagrams provide additional information concerning board functionality and component layout.

### 1.4.1 System Level Interfacing

Because the PMC240 may be used with either a separate carrier board or with a CPU board which provides interfacing to a PMC module, two System Level Interfacing (SLI) diagrams have been provided to demonstrate these implementation possibilities. SLI Figure 1-1 demonstrates system interfacing when used with a CPCI carrier board, and SLI Figure 1-2 demonstrates the interfacing with a CPU board which supports PMC modules.

In the case of CPU boards, the PMC module may directly be installed on the CPU board itself or be coupled to the CPU board through an intermediate carrier board. In either event, the functional interfacing to the CPU board is not through a backplane bus.

#### 1.4.1.1 SLI with PMC Carrier Board

This implementation depends on application requirements and available system resources. The implementation can range anywhere from a single 3U PMC carrier board to multiple 6U dual PMC carrier boards.



Figure 1-1: System Level Interfacing with PMC Carrier Board

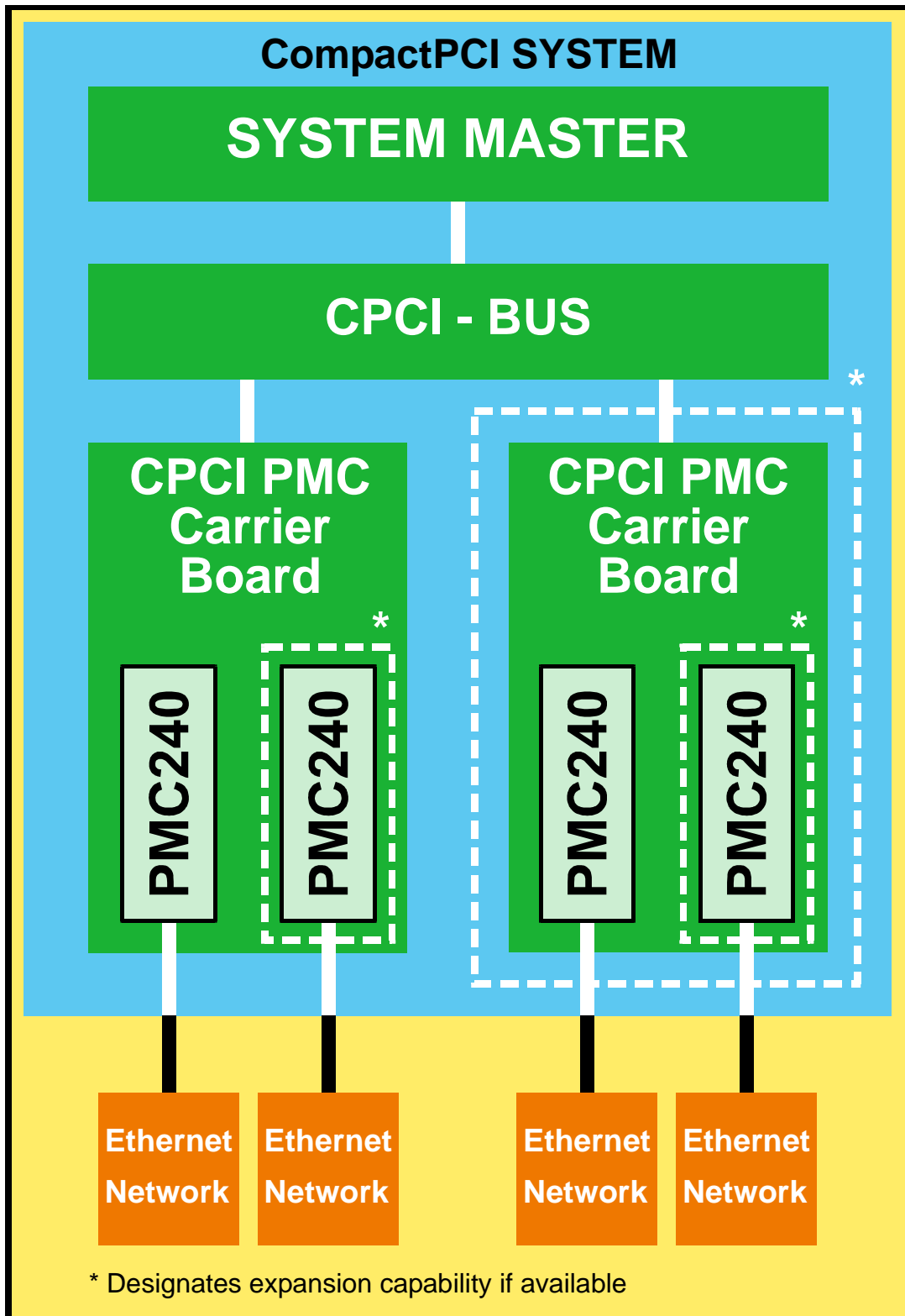



#### 1.4.1.2 SLI with CPU Board

This implementation primarily depends on the type of CPU board in use. As the PMC240's system interface is based on the PCI-bus, the CPU board must support this type of interfacing in some way. With CPU boards which are compliant with the CMC / PMC standard, the PMC240 may be directly installed in any available PMC socket. Other CPU board types may require the use of some intermediate carrier board for interfacing to the CPU board.

An example of such a configuration is *PEP Modular Computers'* VMP1 CPU board which interfaces with the VMP1-IO1 PMC carrier board. This board itself is a type of VME mezzanine board which interfaces directly to the VMP1 CPU board via the PCI Expansion Connector.

Application expansion capabilities using this implementation are a direct function of the type of CPU board used and its associated hardware.





Figure 1-2: System Level Interfacing with CPU Board

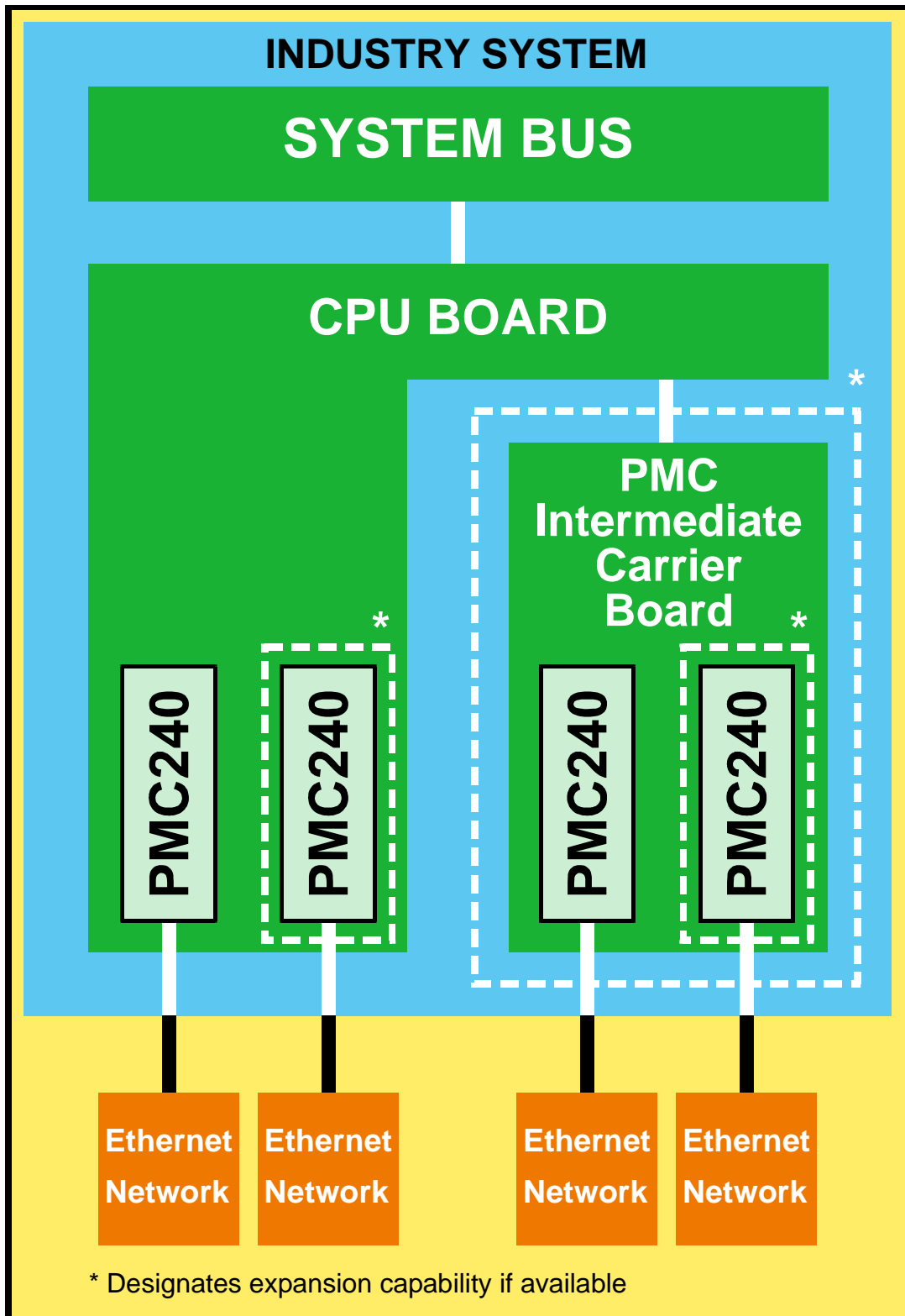



### 1.4.2 Front Panels

There are four standard variants of the PMC240 available:

- Variant A: Channel A, single RJ45 connector; Channel B not populated
- Variant B: Channels A and B, double RJ45 connectors
- Variant C: Channel A, RJ45 connector; Channel B, SC-type fiber optic connector
- Variant D: Channels A and B, SC-type fiber optic connectors

The figure below shows the front panel layout for each of the above variants:

**Figure 1-3: PMC240 Front Panel Standard Variant Views**

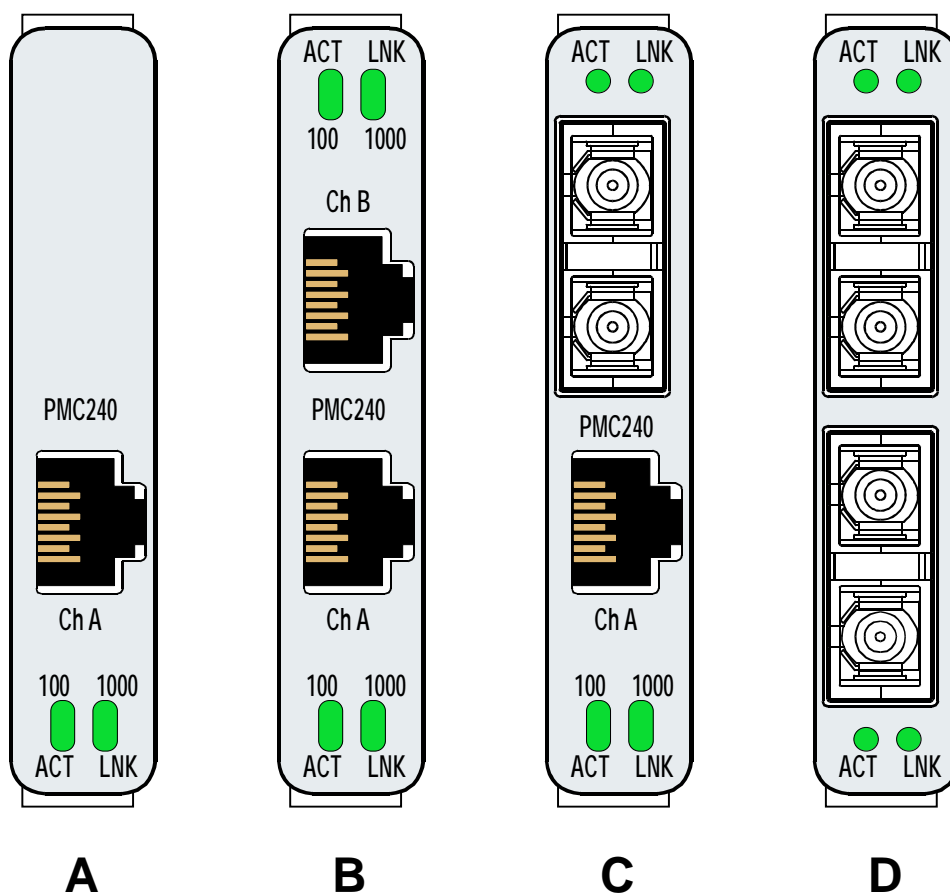

### 1.4.3 Board Layouts

The following figures show the board layouts for the above indicated variants of the PMC240 module.



Figure 1-4: PMC240 Variant A

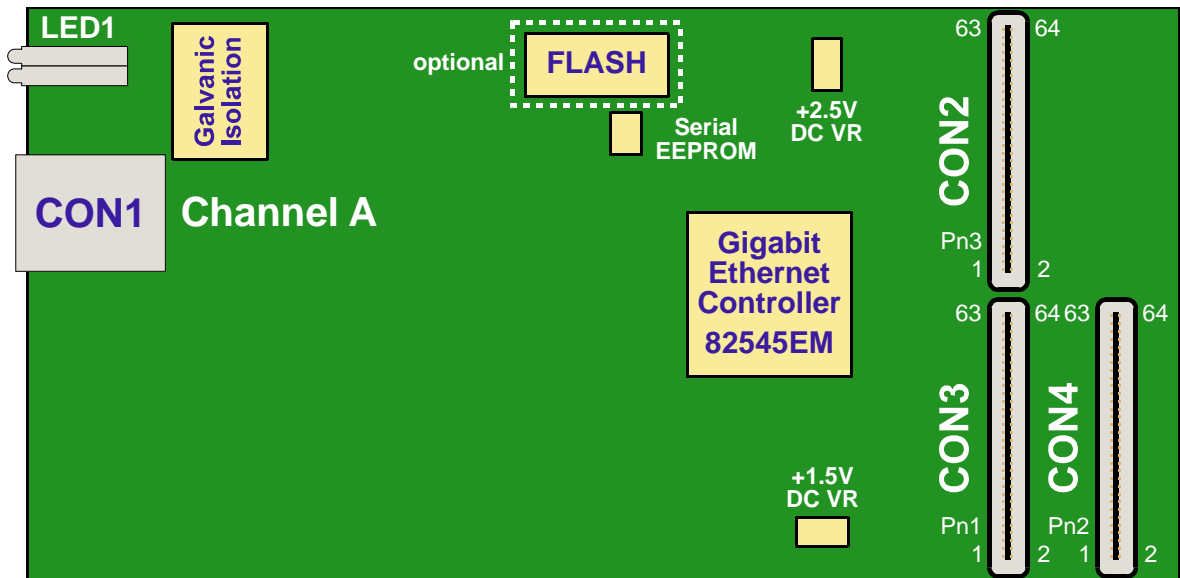

Figure 1-5: PMC240 Variant B

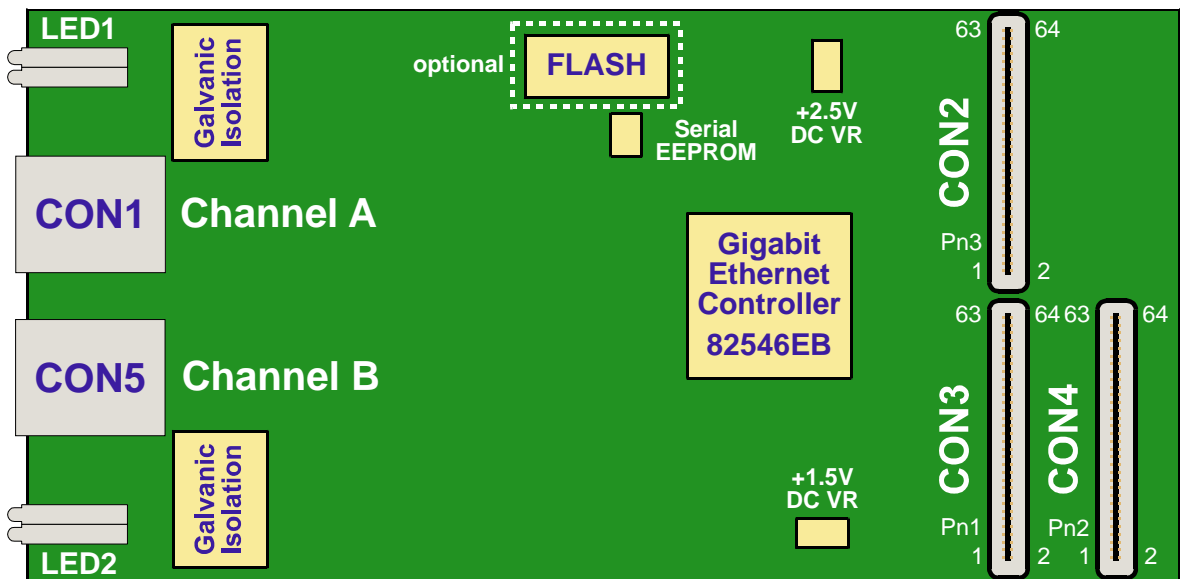



Figure 1-6: PMC240 Variant C

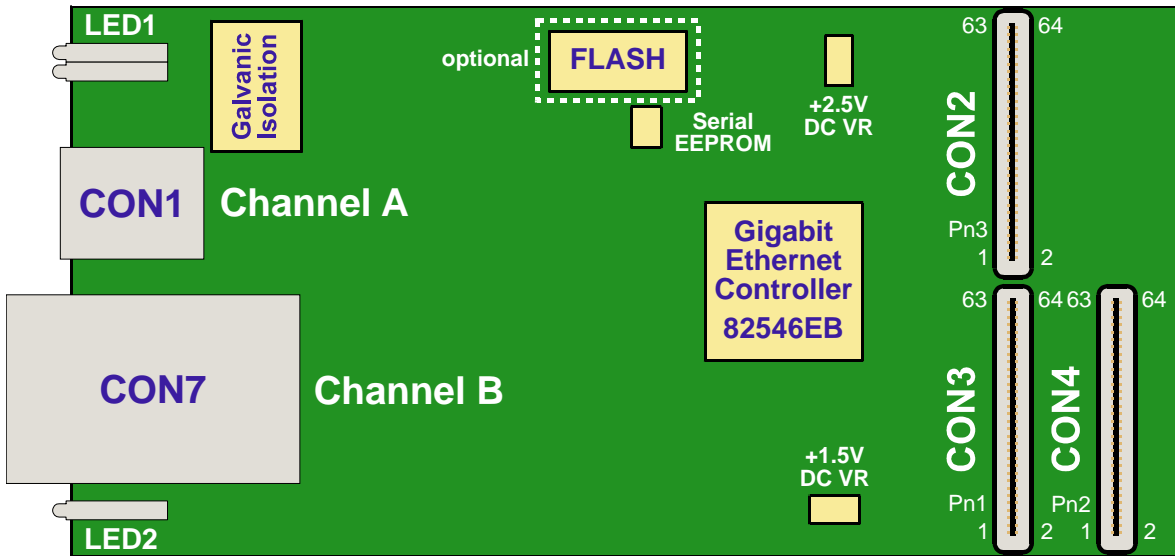
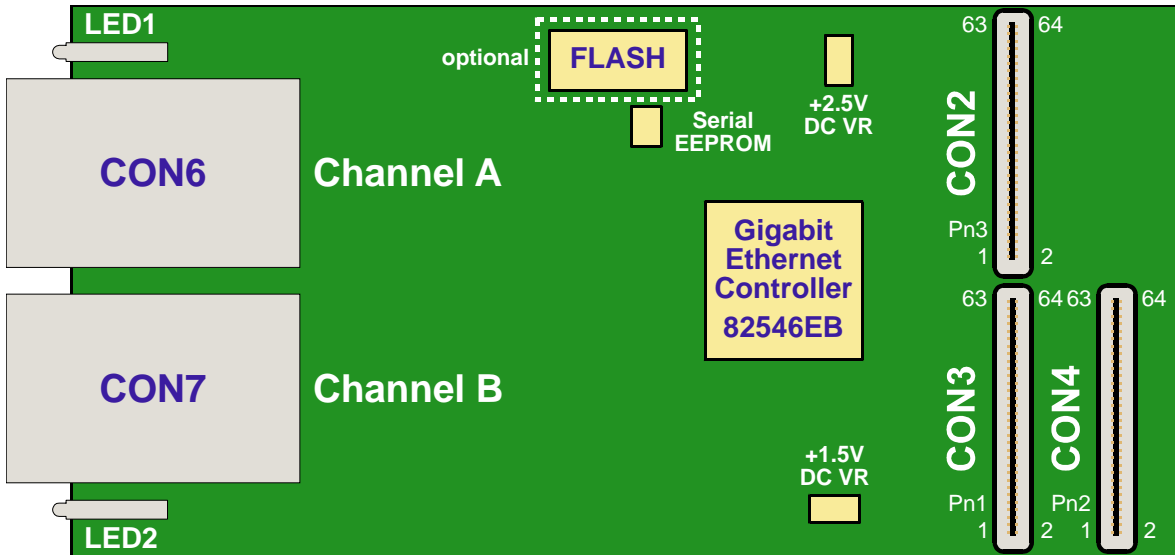

Figure 1-7: PMC240 Variant D





## 1.5 Technical Specifications

Table 1-2: PMC240 Main Specifications

GROUP	TYPE	DESCRIPTION
CONTROLLER	Intel® Gigabit Ethernet Controller:	Provides single or dual channel Gigabit Ethernet functionality including PHY / SERDES and PCI interfacing. Ethernet standards supported: <ul style="list-style-type: none"> <li>• 10Base-T</li> <li>• 100Base-TX</li> <li>• 1000Base-T</li> <li>• 1000Base-SX</li> </ul>
	82545EM single channel 82546EB dual channel	
Peripheral Memory	Configuration EEPROM	1 Mbit (64 x 16 organization) EEPROM
	Flash Memory	Up to 512 kB of soldered Flash memory (optional)
External Interfaces	Ethernet copper	Up to two, 8-contact, female, RJ45 connector(s) Supports one or two channels of full or half duplex 10Base-T, 100Base-TX, or 1000Base-T Ethernet operation up to 100 meters cable length.
	Ethernet fiber optic	Up to two, SC type fiber optic, transceiver connector(s) Supports one or two channels of full duplex 1000Base-SX Ethernet operation up to 550 meters link length.
	PCI / PCI-X	Three, 64-contact, male, PMC connectors (Pn1, Pn2, Pn3) CMC/PMC standard compliant including: <ul style="list-style-type: none"> <li>• 33, 66, and 133 MHz operation</li> <li>• 32 and 64 bit addressing</li> <li>• PCI 2.2 and PCI-X 1.0a</li> </ul>
Indicators	Front Panel LED	Two sets of up to four, green LED's for indicating Ethernet channel operational status: LED1 and LED2: <ul style="list-style-type: none"> <li>• ACT: indicates channel activity</li> <li>• LNK: indicates Ethernet link status</li> <li>• 100: indicates link speed = 100 M-bits</li> <li>• 1000: indicates link speed = 1000 M-bits (Gigabit)</li> </ul>
General	Mechanical	Conforms with CMC: P1386.1/Draft 2.4a, 21-Mar-01
	Power Requirements	Voltages: board power supply: 3.3 V (± 5%) V (I/O): 3.3 or 5 V
	Power Consumption	See Table 1-3 for details
	Temperature Range	Operational: 0°C to +70°C Standard (see note) Storage: -40°C to +100°C Note: Ethernet controller: 82546EB requires cooling air flow of 1 m/s or more for operation above 55° C.
	Humidity	0% to 95% non-condensing
	Dimensions	74 mm x 149 mm single height CMC/PMC card
	Board Weight	152 g (2 fiber optic transceivers)

**Table 1-2: PMC240 Main Specifications (Continued)**

GROUP	TYPE	DESCRIPTION
Software Driver Information	PCI Header	Device ID: 0x1010 (copper); 0x1012 (fiber optic) Vendor ID: 0x8086 Class Code: 0x020000 Subsystem Device ID: 0x1010 (copper only) 0x1012 (fiber optic only) 0x1011 (copper / fiber optic mixed) Subsystem Vendor ID: 0x8086

**Table 1-3: PMC240 Power Consumption**

VARIANT *	POWER CONSUMPTION AT 3.3 V (typical)			
	OPERATIONAL CONFIGURATION **			
	NO LINK	10 MBITS	100 MBITS	1000 MBITS
A	380 mA	420 mA	490 mA	980 mA
B	250 mA	310 mA	460 mA	1470 mA
C	460 mA	480 mA (copper only)	550 mA (copper only)	1060 mA (copper only) 470 mA (optical only) 1070 mA (both)
D	670 mA	—	—	700 mA

- \* Variants: A: single channel, copper  
B: dual channel, copper  
C: single channel, copper; single channel, optical  
D: dual channel, optical

\*\* Operational Configuration: All available channels in operation except where otherwise noted. All measurements at 33 MHz PCI bus operation.



## 1.6 Applied Standards

The PMC240 complies with the requirements of the following standards:

**Table 1-4: Applied Standards**

	TYPE	STANDARD
CE	Emission	EN50081-1
	Immunity, Industrial Environment	EN50082-2
	Immunity, IT Equipment	EN55024
	Electrical Safety	EN60950
MECHANICAL	Mechanical Dimensions	CMC: P1386.1 / Draft 2.4a, 21-Mar-01
ENVIRONMENTAL TESTS	Vibration, Sinusoidal	IEC68-2-6
	Random Vibration, Broadband	IEC68-2-64 (3U boards)
	Permanent Shock	IEC68-2-29
	Single Shock	IEC68-2-27

## 1.7 Related Publications

**Table 1-5: Related Publications**

	ISSUED BY	DOCUMENT
CompactPCI Systems	PICMG	CompactPCI Specification, V. 2.0, Rev. 3.0
	<i>PEP Modular Computers</i>	CompactPCI Systems Manual (ID 19953)
PCI Local Bus	PCI Special Interest Group	PCI Local Bus Specification, 2.2, December 18, 1998
		PCI-X Addendum to the PCI Local Bus Specification, Revision 1.0a (PCI-X 1.0a), August 29, 2000



This page was intentionally left blank.







*Chapter*

**2**

---

# Functional Description

---



This page was intentionally left blank.





## 2. Functional Description

The following chapters present more detailed, board level information about the PMC240 Dual Channel Gigabit Ethernet Controller whereby the board components and their basic functionality are discussed in general.

### 2.1 General Information

The PMC240 is comprised basically of the following:

- Signal conditioning: either (depends on the variant)
  - Galvanic isolation for CAT5 UTP cabling, or
  - Full duplex transceiver for fiber optic links
- Gigabit Ethernet controller
  - Dual or single channel controller
  - Integrated (on single chip):
    - PCI / PCI-X interface
    - MAC
    - Gigabit PHY
    - SERDES
- System interfaces for:
  - Up to two Gigabit Ethernet channels
    - One RJ45, 8-contact, female connector per channel for CAT5 UTP cabling (CON1 and CON5 if populated)
    - One SC-type fiber optic transceiver connector per channel for fiber optic linking (CON6 and CON7 if populated)
  - PCI / PCI-X compliant bus
    - Three 64-contact, male, CMC / PMC compliant connectors (CON2, CON3, CON4)
    - Interfacing direct with CPU or PMC carrier board
- On board memory:
  - Configuration EEPROM
  - Up to 512 kB soldered Flash memory (optional)
- Monitor and Control
  - Depending on variant, up to two sets of four green operational status LED's for monitoring of link status, operational mode (link speed), and channel activity
- Software
  - Windows® driver from Intel®
  - Linux®
  - VxWorks®

#### 2.1.1 Signal Conditioning

Signal conditioning is a function of the type of network being serviced by the individual PMC240 channel. Copper cabling networks are provided with galvanic isolation whereas fiber optic links are interfaced using SC-type fiber optic connectors with integrated transceivers for full duplex operation.



## 2.1.2 Gigabit Ethernet Controller

Within the PMC240, the Gigabit Ethernet controller is responsible for providing up to two channels of full Gigabit Ethernet MAC and PHY layer functionality and for PCI / PCI-X bus interfacing for system communications either direct with a CPU host or via a carrier board to a CPU host or system master. In addition, there is on-chip SERDES for both Ethernet channels to service fiber optic links thus eliminating the need for a separate, external SERDES chip.

Because the design of the PMC240 allows for either of the two Intel® Gigabit Ethernet Controllers (82546EB for dual port; 82545EM for single port) to be populated, there are various configurations possible ranging from a single channel copper solution to dual channel fiber optic solution.

## 2.1.3 System Interfaces

The PMC240 provides interfacing capability for the following system elements:

- One or two Gigabit Ethernet interfaces
- PCI / PCI-X bus interfacing

Ethernet interfacing is achieved either via the CON1(RJ45), CON5 (RJ45), CON6 (SC), or CON7 (SC) connectors depending on the PMC240 variant in use and the type of network link: copper or fiber optic. One of the features of the Gigabit Ethernet controller is that it can automatically detect signal polarity so there is no need for using crossover cabling for direct copper links to a CPU board.

Interfacing to the PCI / PCI-X bus is accomplished via the CON2 (Pn3), CON3 (Pn1), and CON4 (Pn2) CMC / PMC standard compliant connectors.

## 2.1.4 On Board Memory

There is 1 Mbit of EEPROM memory available for storing configuration information for use by the Gigabit Ethernet controller. This EEPROM is factory programmed, and for standard operation implementations no changes are required. In addition, up to 512 kByte of soldered Flash memory is available as an option for onboard storage of data or executable binary images.

## 2.1.5 Monitor and Control

Various LED's are available depending on the variant in use for monitoring network operation. Basically there is always the possibility to determine if a link is available (LNK on) and if there is activity on the link (ACT blinking). In addition, with copper links the operational mode (10, 100, 1000 Mbits) is indicated accordingly whereby when neither the 100 or 1000 LED is on the operational mode is 10 Mbit. For fiber optic interfaces the mode is always 1000 Mbits.

## 2.1.6 Software

The PMC240 requires operating system driver software to operated. For the PMC240 drivers are available for Windows®, Linux®, and VxWorks®.



## 2.2 Board-Level Interfacing Diagram

The following figure demonstrates the interfacing structure between the internal processing modules of the PMC240 and other major PMC240 system components. Where PMC240 system elements have common interfacing they are grouped into a block. Interfacing common to only one element of a block is indicated with a direct connecting line. The interfacing lines are shown in white where they are on board and in black for board external interfacing.

The “\*” (asterisk) in the figure blocks indicate that the actual implementation depends on the system configuration and the PMC240 variant employed. As a minimum, at least one channel of up to 1000Base-T capability is available. A maximum of two channels of the same or varying link type can be implemented. Flash memory is always an optional feature which must be stipulated along with the variant.

Legend for Figure 2-1:

- GALV.ISOL. = galvanic isolation for copper links
- SC TRCV = SC-type transceiver for fiber optic links
- CAT5 UTP = category 5, unshielded twisted pair cabling (copper links)
- T/R FO = transmit and receive fiber optic links

As the Gigabit Ethernet controller provides automatic detection of the Ethernet standard in use on copper links the PMC240 may be used with any mix of Ethernet networks from 10Base-T to 1000Base-T.



Figure 2-1: PMC240 Board Level Interfacing

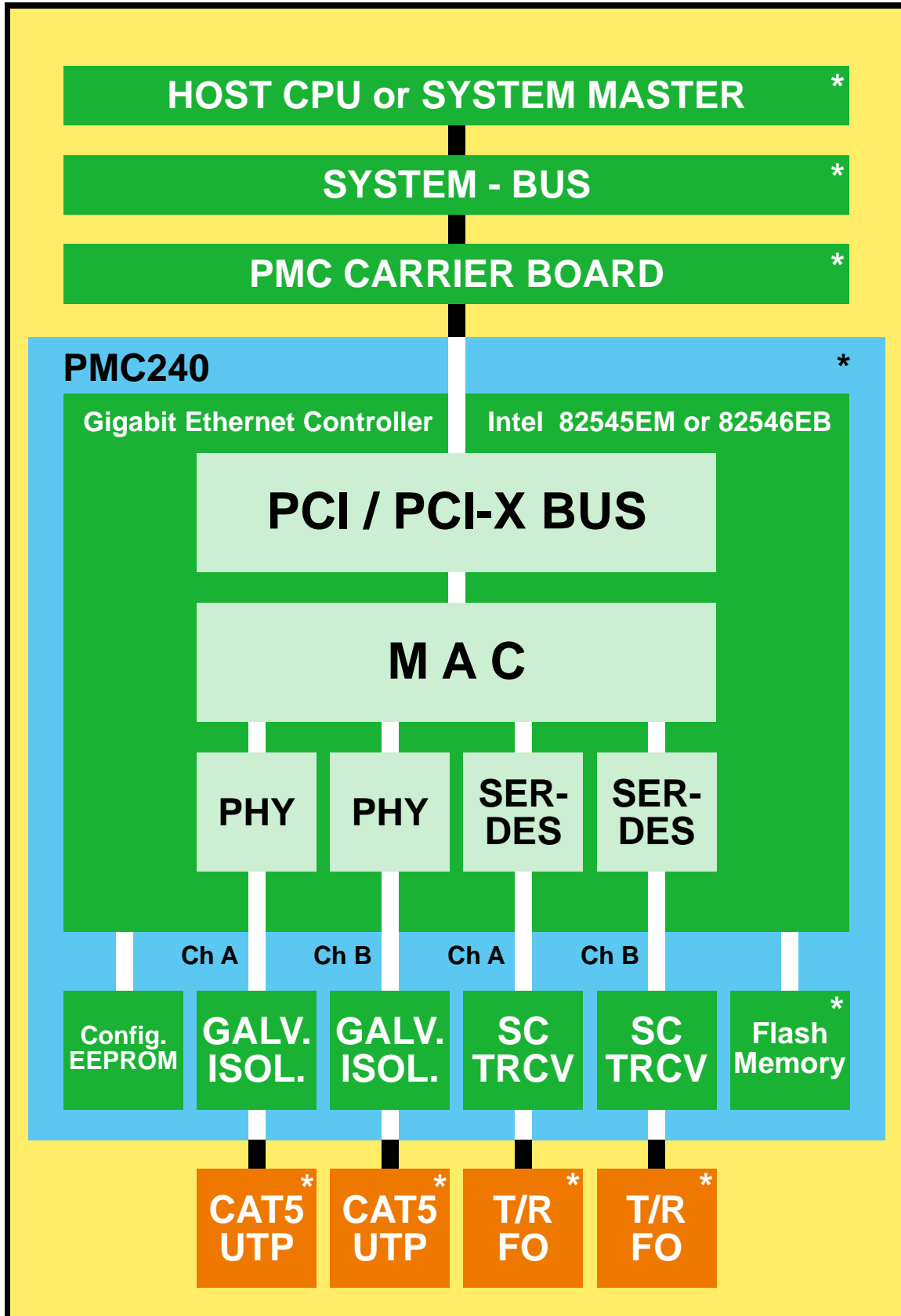



## 2.3 System Interfaces

### 2.3.1 Ethernet Wire Cabling Interface

The Ethernet wire cabling interface is implemented using up to two 8-contact, female, RJ45 connectors. CON1 is implemented as Channel A when installed, and CON5 is implemented as Channel B when installed. As the Gigabit Ethernet controller is able to automatically detect the cabling configuration and Ethernet standard in use, the pinout of the individual connectors is a function of the implementation.

**Figure 2-2: CON1 and CON5 Connectors**

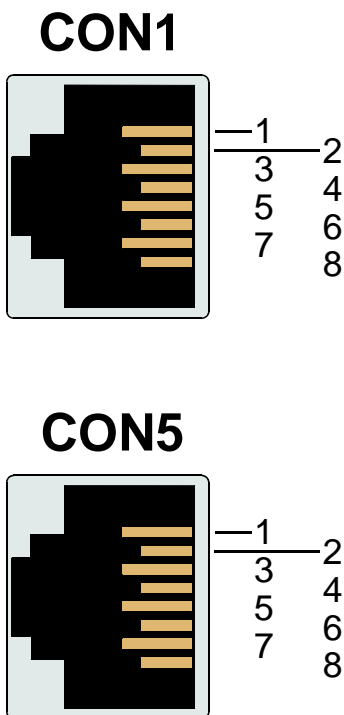

The following figure and table indicate the pin assignment and signal function for each connector as a function of the implementation.

The signal pinouts on the left side of the table are for the standard Media Dependent Interface (MDI) using appropriate CAT5 UTP cabling for the Ethernet standard in use.

The signal pinouts on the right side of the table are for the Media Dependent Interface Crossed (MDIX) using appropriate CAT5 UTP cabling for the Ethernet standard in use.

In addition, the input / output status of each signal is also indicated in the table.

**Table 2-1: Pinouts of CON1 and CON5 Based on the Implementation**

MDI / Standard Ethernet Cable						PIN	MDIX / Crossed Ethernet Cable					
10BASE-T		100BASE-TX		1000BASE-T			10BASE-T		100BASE-TX		1000BASE-T	
I/O	SIGNAL	I/O	SIGNAL	I/O	SIGNAL		I/O	SIGNAL	I/O	SIGNAL	I/O	SIGNAL
O	TX+	O	TX+	I/O	BI_DA+	1	I	RX+	I	RX+	I/O	BI_DB+
O	TX-	O	TX-	I/O	BI_DA-	2	I	RX-	I	RX-	I/O	BI_DB-
I	RX+	I	RX+	I/O	BI_DB+	3	O	TX+	O	TX+	I/O	BI_DA+
-	-	-	-	I/O	BI_DC+	4	-	-	-	-	I/O	BI_DD+
-	-	-	-	I/O	BI_DC-	5	-	-	-	-	I/O	BI_DD-
I	RX-	I	RX-	I/O	BI_DB-	6	O	TX-	O	TX-	I/O	BI_DA-
-	-	-	-	I/O	BI_DD+	7	-	-	-	-	I/O	BI_DC+
-	-	-	-	I/O	BI_DD-	8	-	-	-	-	I/O	BI_DC-



### 2.3.2 Ethernet Fiber Optic Interface

The Ethernet fiber optic interface is realized using one Agilent HFBR-53A5VEM Fiber Optic Transceiver for each Ethernet channel. These transceivers support full duplex 1000Base-SX operation and are fitted with a duplex SC-type connector receptacle for interfacing to fiber optic links. CON6 is implemented as Channel A when installed, and CON7 is implemented as Channel B when installed.

The following figure indicates the positioning of the transmit and receive receptacles and orientation of the connectors and keying of the receptacles. The SC-type receptacle is designed to support self-locking duplex SC-type male connectors. This ensures that the fiber optic links are securely fastened to the receptacles.

Figure 2-3: CON6 and CON7 Fiber Optic Receptacles

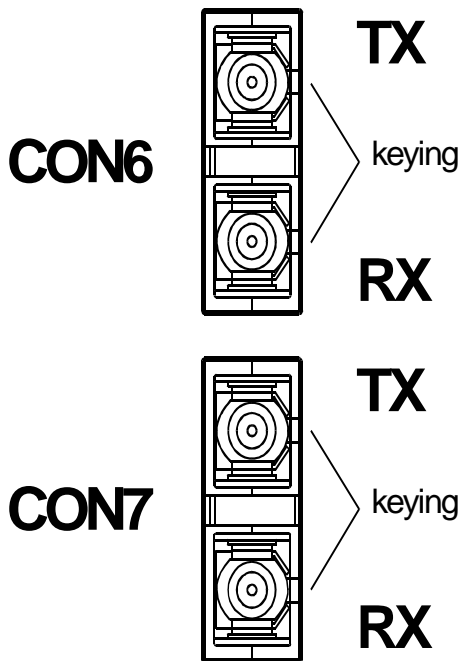

### 2.3.3 PCI / PCI-X Interface

The PCI / PCI-X interface is CMC / PMC compliant and is realized using three, 64-contact, male connectors: CON2 (Pn3), CON3 (Pn1), and CON4 (Pn2). The following figure and tables provide pinout information for this interface.

Figure 2-4: Pinouts of CON3, CON4, and CON2

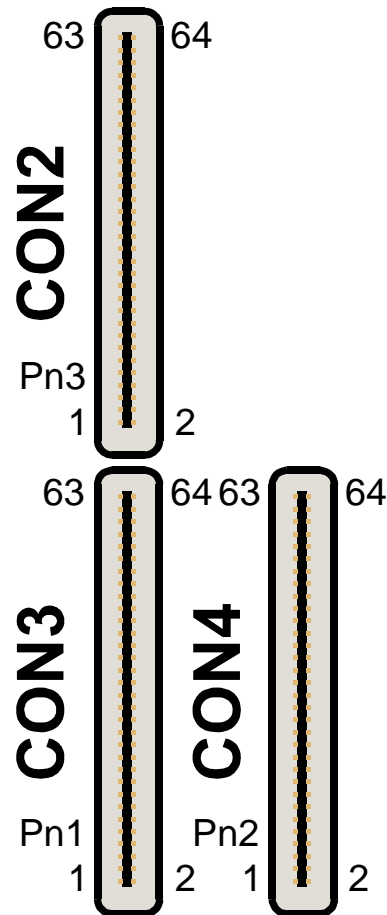





Table 2-2: Pinouts of CON3, CON4, and CON2

CON2	CON4	CON3	PIN	PIN	CON3	CON4	CON2
Pn3	Pn2	Pn1			Pn1	Pn2	Pn3
reserved	+12V	TCK	1	2	-12V	TRST#	GND
GND	TMS	GND	3	4	INTA#	TDO	C/BE[7]#
C/BE[6]#	TDI	INTB#	5	6	INTC#	GND	C/BE[5]#
C/BE[4]#	GND	BUSMODE1#	7	8	+5V	reserved	GND
V (I/O)	reserved	INTD#	9	10	reserved	reserved	PAR64
AD[63]	BUSMODE2#	GND	11	12	3.3Vaux	+3.3V	AD[62]
AD[61]	RST#	CLK	13	14	GND	BUSMODE3#	GND
GND	+3.3V	GND	15	16	GNT#	BUSMODE4#	AD[60]
AD[59]	PME#	REQ#	17	18	+5V	GND	AD[58]
AD[57]	AD[30]	V (I/O)	19	20	AD[31]	AD[29]	GND
V (I/O)	GND	AD[28]	21	22	AD[27]	AD[26]	AD[56]
AD[55]	AD[24]	AD[25]	23	24	GND	+3.3V	AD[54]
AD[53]	IDSEL	GND	25	26	C/BE[3]#	AD[23]	GND
GND	+3.3V	AD[22]	27	28	AD[21]	AD[20]	AD[52]
AD[51]	AD[18]	AD[19]	29	30	+5V	GND	AD[50]
AD[49]	AD[16]	V (I/O)	31	32	AD[17]	C/BE[2]#	GND
GND	GND	FRAME#	33	34	GND	reserved	AD[48]
AD[47]	TRDY#	GND	35	36	IRDY#	+3.3V	AD[46]
AD[45]	GND	DEVSEL#	37	38	+5V	STOP#	GND
V (I/O)	PERR#	GND	39	40	LOCK#	GND	AD[44]
AD[43]	+3.3V	reserved	41	42	reserved	SERR#	AD[42]
AD[41]	C/BE[1]#	PAR	43	44	GND	GND	GND
GND	AD[14]	V (I/O)	45	46	AD[15]	AD[13]	AD[40]
AD[39]	M66EN	AD[12]	47	48	AD[11]	AD[10]	AD[38]
AD[37]	AD[08]	AD[09]	49	50	+5V	+3.3V	GND
GND	AD[07]	GND	51	52	C/BE[0]#	reserved	AD[36]
AD[35]	+3.3V	AD[06]	53	54	AD[05]	reserved	AD[34]
AD[33]	reserved	AD[04]	55	56	GND	GND	GND
V (I/O)	reserved	V (I/O)	57	58	AD[03]	reserved	AD[32]
reserved	GND	AD[02]	59	60	AD[01]	reserved	reserved
reserved	ACK64#	AD[00]	61	62	+5V	+3.3V	GND
GND	GND	GND	63	64	REQ64#	reserved	reserved



## 2.4 Onboard Memory

### 2.4.1 Configuration EEPROM

The Configuration EEPROM is a 1 MBit (128 kB, 64 x 16 organization) EEPROM for storing board control relevant information for the operation of the Gigabit Ethernet controller as well as the PCI / PCI-X interfacing to a host CPU or System Master.

### 2.4.2 Flash Memory

The PMC240 has provision for adding up to 512 kB of optional Flash memory for additional data storage. This memory is controlled by the Gigabit Ethernet device but is accessible from a host CPU or System Master. As such this memory can be used for a variety of functionality including the ability to boot a host CPU or System Master from LAN.

## 2.5 Monitor and Control (M/C)

Monitor and Control functions are divided essentially into Pre-operation and Operation. Pre-operation M/C deals with board configuration and system requirements. Operation M/C covers direct operator interfaces.

### 2.5.1 Pre-Operation M/C

Pre-operation M/C is a direct function of the application and the system requirements. These requirements dictate the module configuration as well as the overall system integration. Overall system integration and compliance with its requirements is beyond the scope of this manual.

### 2.5.2 Operation M/C

Operation M/C is a function of the PMC240 driver software and the application. Direct interaction by the operator is limited to the functionality provided by the LED's assigned to the respective Ethernet channels. These LED's can be used to determine the basic operational status of a channel and if data is being transferred.



---

*Chapter*

---

**3**

---

# Installation

---



This page was intentionally left blank.





## 3. Installation

The PMC240 has been designed for easy installation. However, the following standard precautions, installation procedures, and general information must be observed to ensure proper installation and to preclude damage to the board or injury to personnel.

### 3.1 Hardware Installation

The product described in this manual can be installed in any available CMC / PMC compliant carrier or CPU board (host).

#### 3.1.1 Safety Requirements

The board must be securely fastened to the host using appropriate retaining screws and stand-offs to ensure proper grounding and to avoid loosening caused by vibration or shock.

In addition the following electrical and mechanical hazard precautions must be observed.



#### **Caution, Electric Shock Hazard!**

Ensure that the system main power is removed prior to installing or removing this board. Ensure that there are no other external voltages or signals being applied to this board or other boards within the system. Failure to comply with the above could endanger your life or health and may cause damage to this board or other system components including process-side signal conditioning equipment.



#### **ESD Equipment!**

This PEP board contains electrostatically sensitive devices. Please observe the following precautions to avoid damage to your board:

Discharge your clothing before touching the assembly. Tools must be discharged before use.

If working at an anti-static workbench with professional discharging equipment, ensure compliance with its usage when handling this product. Otherwise, avoid as much as possible contact with on board components, connector pins, or board conductive circuits.



#### **Warning!**

Variants of the PMC240 with fiber optic connectors have connector EMC shielding which can be damaged by improper handling during installation or removal. **DO NOT USE ANY FORCE** when (de-)mating the PMC240 bezel and the front panel. It can happen that the shielding tabs snag on the host board and get damaged if force is applied!

If necessary, partially disassemble the host front panel to free the PMC240.



### 3.1.2 Installation Procedures

To install the board proceed as follows:

1. Ensure that the safety requirements indicated above are observed.



#### **Warning!**

Failure to comply with the instruction below may cause damage to the board or result in improper system operation.

2. Ensure that the board is properly configured for operation before installing.



#### **Warning!**

Care must be taken when applying the procedures below to ensure that neither the PMC240 nor the host board is physically damaged by the application of these procedures.

3. To install the PMC240 perform the following referring to Figure 3-1 as required:
  1. Obtain host board and ensure that it satisfies application requirements and will allow for proper installation of the PMC240: e.g. connectors match, front panel cutout matches, holes for mounting screws are available and match, standoffs can be properly installed, except for prescribed contact points no other contact between host and PMC240 after mating occurs, etc.
  2. Attach the two 10 mm standoffs supplied with the PMC240 to the PMC240.
  3. Ensure that the EMC gasket is properly installed on PMC240 bezel.
  4. Carefully insert the PMC240 into the front panel cutout of the host board ensuring that the EMC gasket is properly seated on the front panel.
  5. Ensuring that Pn1, Pn2, and Pn3 are properly aligned with Jn1, Jn2, and Jn3 of the host board, press the PMC240 and host board together so that their connectors are completely engaged.
  6. Install the four PMC240 retaining screws ensuring that the PMC240 is properly mated to the host board: e.g. PMC bezel flush with front panel, no misalignment of connectors, no contact between host and PMC240 except as prescribed, etc.
4. For installation of the host board with the PMC240 mounted in a system refer to the installation procedures for the host board.



#### **Warning!**

Proper and safe operation of the PMC240 Dual Gigabit Ethernet Controller depends on the correct configuration of input signals and signal conditioning. System integrators must ensure that all signals presented to the PMC240 comply with the specifications set forth in this manual.

Failure to comply with the above may cause damage to the board or result in improper system operation.



Figure 3-1: Installation / Removal Diagrams

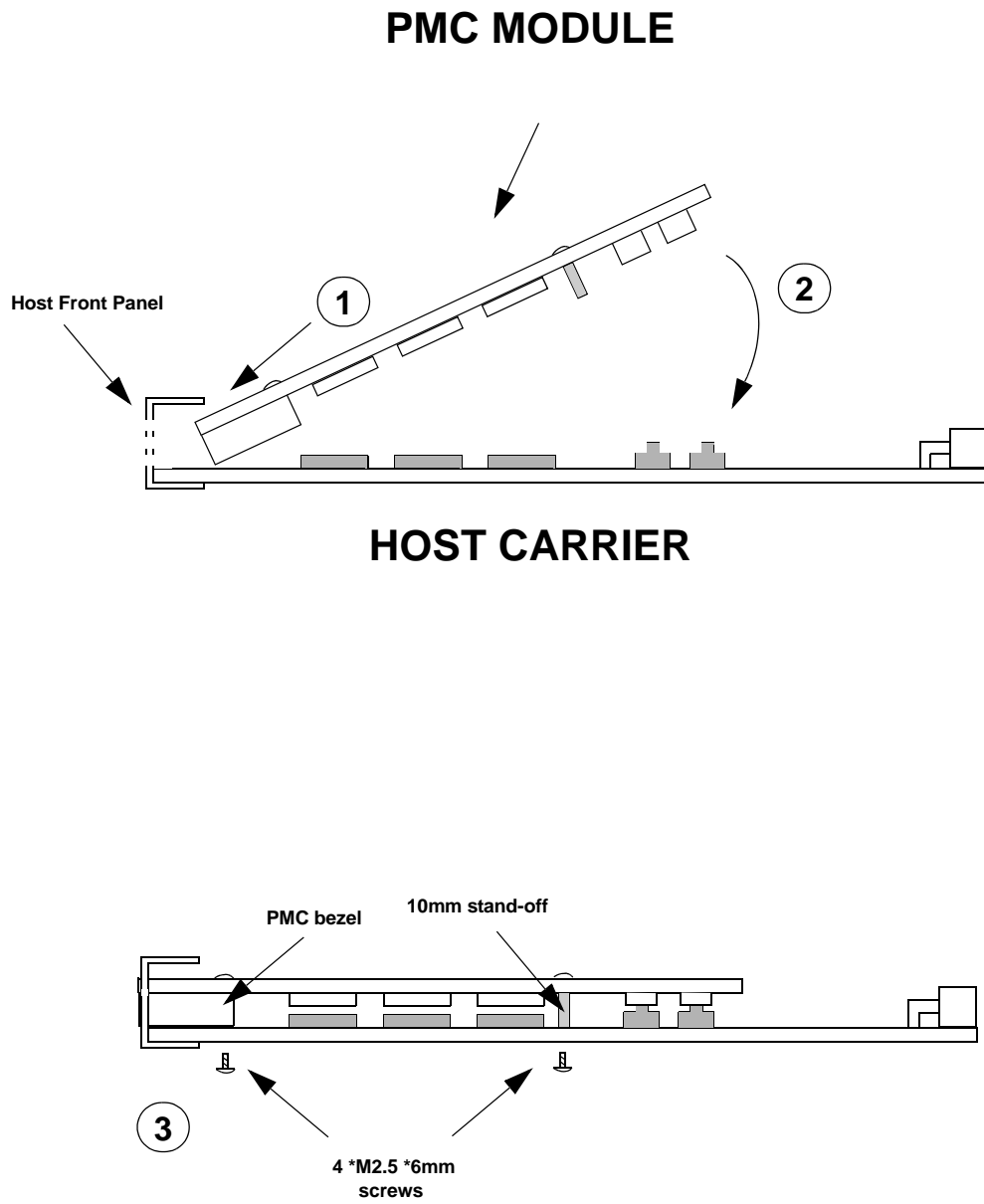



### 3.1.3 Removal Procedures

To remove the PMC240 from the host board proceed as follows:

1. Ensure that the safety requirements indicated above are observed.



#### **Warning!**

Care must be taken when applying the procedures below to ensure that neither the PMC240 nor the host board is physically damaged by the application of these procedures.

2. If applicable, remove the host board from system using host board removal procedures.
3. To remove the PMC240 perform the following referring to Figure 3-1 as required:
  1. Obtain host board.
  2. Remove the four PMC240 retaining screws.
  3. Carefully disengage the Pn1, Pn2, and Pn3 connectors so that no force or movement is applied to the PMC240 bezel.
  4. Ensure that the PMC240 bezel is not jammed or hung up on the host board. If necessary, partially disassemble the host board front panel to free the PMC240 bezel.
  5. Slide the PMC240 away from the front panel.
  6. Dispose of the PMC240 as required.
4. Dispose of the host board as required.

## 3.2 Software Installation

Installation of the PMC240 driver software is a function of the application operating system. For further information refer to the appropriate software documentation.





---

*Chapter*

---



---

# Configuration

---



This page was intentionally left blank.





## 4. Configuration

The PMC240 is designed for plug and play operation, and, as such, it does not have any user configurable board settings which are required for operation.

For application usage of onboard functionality refer to appropriate software documentation.



This page was intentionally left blank.

