

ECX-HSW-U

Doc. User Guide, Rev. 1.2

Doc. ID: [To be Determined]

This page has been intentionally left blank

 ECX-HSW-U - USER GUIDE

Disclaimer

Kontron would like to point out that the information contained in this user guide may be subject to alteration, particularly as a result of the constant upgrading of Kontron products. This document does not entail any guarantee on the part of Kontron with respect to technical processes described in the user guide or any product characteristics set out in the user guide. Kontron assumes no responsibility or liability for the use of the described product(s), conveys no license or title under any patent, copyright or mask work rights to these products and makes no representations or warranties that these products are free from patent, copyright or mask work right infringement unless otherwise specified. Applications that are described in this user guide are for illustration purposes only. Kontron makes no representation or warranty that such application will be suitable for the specified use without further testing or modification. Kontron expressly informs the user that this user guide only contains a general description of processes and instructions which may not be applicable in every individual case. In cases of doubt, please contact Kontron.

This user guide is protected by copyright. All rights are reserved by Kontron. No part of this document may be reproduced, transmitted, transcribed, stored in a retrieval system, or translated into any language or computer language, in any form or by any means (electronic, mechanical, photocopying, recording, or otherwise), without the express written permission of Kontron. Kontron points out that the information contained in this user guide is constantly being updated in line with the technical alterations and improvements made by Kontron to the products and thus this user guide only reflects the technical status of the products by Kontron at the time of publishing.

Brand and product names are trademarks or registered trademarks of their respective owners.

©2021 by Kontron AG

Kontron AG

Lise-Meitner-Str. 3-5
86156 Augsburg
Germany
www.kontron.com

High Risk Applications Hazard Notice

THIS DEVICE AND ASSOCIATED SOFTWARE ARE NOT DESIGNED, MANUFACTURED OR INTENDED FOR USE OR RESALE FOR THE OPERATION OF NUCLEAR FACILITIES, THE NAVIGATION, CONTROL OR COMMUNICATION SYSTEMS FOR AIRCRAFT OR OTHER TRANSPORTATION, AIR TRAFFIC CONTROL, LIFE SUPPORT OR LIFE SUSTAINING APPLICATIONS, WEAPONS SYSTEMS, OR ANY OTHER APPLICATION IN A HAZARDOUS ENVIRONMENT, OR REQUIRING FAIL-SAFE PERFORMANCE, OR IN WHICH THE FAILURE OF PRODUCTS COULD LEAD DIRECTLY TO DEATH, PERSONAL INJURY, OR SEVERE PHYSICAL OR ENVIRONMENTAL DAMAGE (COLLECTIVELY, "HIGH RISK APPLICATIONS").

You understand and agree that your use of Kontron devices as a component in High Risk Applications is entirely at your risk. To minimize the risks associated with your products and applications, you should provide adequate design and operating safeguards. You are solely responsible for compliance with all legal, regulatory, safety, and security related requirements concerning your products. You are responsible to ensure that your systems (and any Kontron hardware or software components incorporated in your systems) meet all applicable requirements. Unless otherwise stated in the product documentation, the Kontron device is not provided with error-tolerance capabilities and cannot therefore be deemed as being engineered, manufactured or setup to be compliant for implementation or for resale as device in High Risk Applications. All application and safety related information in this document (including application descriptions, suggested safety measures, suggested Kontron products, and other materials) is provided for reference only.

Revision History

Revision	Brief Description of Changes	Date of Issue
1.0	Initial Issue	2017-Dec-21
1.1	Add a LPS power supply notice in Sec. 2.1	2020-Apr-13
1.2	Audio codec chip replacement	2021-Apr-07

Terms and Conditions

Kontron warrants products in accordance with defined regional warranty periods. For more information about warranty compliance and conformity, and the warranty period in your region, visit <http://www.kontron.com/terms-and-conditions>.

Kontron sells products worldwide and declares regional General Terms & Conditions of Sale, and Purchase Order Terms & Conditions. Visit <http://www.kontron.com/terms-and-conditions>.

For contact information, refer to the corporate offices contact information on the last page of this user guide or visit our website [CONTACT US](#).

Customer Support

Find Kontron contacts by visiting: <http://www.kontron.com/support>.

Customer Service

As a trusted technology innovator and global solutions provider, Kontron extends its embedded market strengths into a services portfolio allowing companies to break the barriers of traditional product lifecycles. Proven product expertise coupled with collaborative and highly-experienced support enables Kontron to provide exceptional peace of mind to build and maintain successful products.

For more details on Kontron's service offerings such as: enhanced repair services, extended warranty, Kontron training academy, and more visit <http://www.kontron.com/support-and-services/services>.

Customer Comments

If you have any difficulties using this user guide, discover an error, or just want to provide some feedback, contact [Kontron support](#). Detail any errors you find. We will correct the errors or problems as soon as possible and post the revised user guide on our website.

Symbols

The following symbols may be used in this user guide

⚠ DANGER

DANGER indicates a hazardous situation which, if not avoided, will result in death or serious injury.

⚠ WARNING

WARNING indicates a hazardous situation which, if not avoided, could result in death or serious injury.

NOTICE

NOTICE indicates a property damage message.

⚠ CAUTION

CAUTION indicates a hazardous situation which, if not avoided, may result in minor or moderate injury.



Electric Shock!

This symbol and title warn of hazards due to electrical shocks (> 60 V) when touching products or parts of products. Failure to observe the precautions indicated and/or prescribed by the law may endanger your life/health and/or result in damage to your material.



ESD Sensitive Device!

This symbol and title inform that the electronic boards and their components are sensitive to static electricity. Care must therefore be taken during all handling operations and inspections of this product in order to ensure product integrity at all times.



HOT Surface!

Do NOT touch! Allow to cool before servicing.



Laser!

This symbol inform of the risk of exposure to laser beam and light emitting devices (LEDs) from an electrical device. Eye protection per manufacturer notice shall review before servicing.



This symbol indicates general information about the product and the user guide.

This symbol also indicates detail information about the specific product configuration.



This symbol precedes helpful hints and tips for daily use.

For Your Safety

Your new Kontron product was developed and tested carefully to provide all features necessary to ensure its compliance with electrical safety requirements. It was also designed for a long fault-free life. However, the life expectancy of your product can be drastically reduced by improper treatment during unpacking and installation. Therefore, in the interest of your own safety and of the correct operation of your new Kontron product, you are requested to conform with the following guidelines.

High Voltage Safety Instructions

As a precaution and in case of danger, the power connector must be easily accessible. The power connector is the product's main disconnect device.

CAUTION

Warning

All operations on this product must be carried out by sufficiently skilled personnel only.

CAUTION



Electric Shock!

Before installing a non hot-swappable Kontron product into a system always ensure that your mains power is switched off. This also applies to the installation of piggybacks. Serious electrical shock hazards can exist during all installation, repair, and maintenance operations on this product. Therefore, always unplug the power cable and any other cables which provide external voltages before performing any work on this product.

Earth ground connection to vehicle's chassis or a central grounding point shall remain connected. The earth ground cable shall be the last cable to be disconnected or the first cable to be connected when performing installation or removal procedures on this product.

Special Handling and Unpacking Instruction

NOTICE



ESD Sensitive Device!

Electronic boards and their components are sensitive to static electricity. Therefore, care must be taken during all handling operations and inspections of this product, in order to ensure product integrity at all times.

Do not handle this product out of its protective enclosure while it is not used for operational purposes unless it is otherwise protected.

Whenever possible, unpack or pack this product only at EOS/ESD safe work stations. Where a safe work station is not guaranteed, it is important for the user to be electrically discharged before touching the product with his/her hands or tools. This is most easily done by touching a metal part of your system housing.

It is particularly important to observe standard anti-static precautions when changing piggybacks, ROM devices, jumper settings etc. If the product contains batteries for RTC or memory backup, ensure that the product is not placed on conductive surfaces, including anti-static plastics or sponges. They can cause short circuits and damage the batteries or conductive circuits on the product.

Lithium Battery Precautions

If your product is equipped with a lithium battery, take the following precautions when replacing the battery.

CAUTION

Danger of explosion if the battery is replaced incorrectly.

- ▶ Replace only with same or equivalent battery type recommended by the manufacturer.
- ▶ Dispose of used batteries according to the manufacturer's instructions.

General Instructions on Usage

In order to maintain Kontron's product warranty, this product must not be altered or modified in any way. Changes or modifications to the product, that are not explicitly approved by Kontron and described in this user guide or received from Kontron Support as a special handling instruction, will void your warranty.

This product should only be installed in or connected to systems that fulfill all necessary technical and specific environmental requirements. This also applies to the operational temperature range of the specific board version that must not be exceeded. If batteries are present, their temperature restrictions must be taken into account.

In performing all necessary installation and application operations, only follow the instructions supplied by the present user guide.

Keep all the original packaging material for future storage or warranty shipments. If it is necessary to store or ship the product then re-pack it in the same manner as it was delivered.

Special care is necessary when handling or unpacking the product. See Special Handling and Unpacking Instruction.

Quality and Environmental Management

Kontron aims to deliver reliable high-end products designed and built for quality, and aims to complying with environmental laws, regulations, and other environmentally oriented requirements. For more information regarding Kontron's quality and environmental responsibilities, visit <http://www.kontron.com/about-kontron/corporate-responsibility/quality-management>.

Disposal and Recycling

Kontron's products are manufactured to satisfy environmental protection requirements where possible. Many of the components used are capable of being recycled. Final disposal of this product after its service life must be accomplished in accordance with applicable country, state, or local laws or regulations.

WEEE Compliance

The Waste Electrical and Electronic Equipment (WEEE) Directive aims to:

- ▶ Reduce waste arising from electrical and electronic equipment (EEE)
- ▶ Make producers of EEE responsible for the environmental impact of their products, especially when the product become waste
- ▶ Encourage separate collection and subsequent treatment, reuse, recovery, recycling and sound environmental disposal of EEE
- ▶ Improve the environmental performance of all those involved during the lifecycle of EEE



Environmental protection is a high priority with Kontron.

Kontron follows the WEEE directive

You are encouraged to return our products for proper disposal.

Table of Contents

Symbols	6
For Your Safety	7
High Voltage Safety Instructions	7
Special Handling and Unpacking Instruction	7
Lithium Battery Precautions.....	8
General Instructions on Usage	8
Quality and Environmental Management	8
Disposal and Recycling.....	8
WEEE Compliance.....	8
Table of Contents	9
List of Tables	10
List of Figures	11
1/ Introduction	13
2/ Installation Procedures	14
2.1. Installing the Board	14
2.2. Chassis Safety Standards.....	15
2.3. Lithium Battery Replacement	15
3/ System Specifications	17
3.1. System Block Diagram.....	17
3.2. Component Main Data	18
3.3. Environmental Conditions	19
3.4. Standards and Certifications.....	19
3.5. Processor Support.....	19
3.6. System Memory Support.....	20
3.6.1. Memory Operating Frequencies	20
3.7. On-board Graphics Subsystem.....	21
3.8. Power Supply.....	21
4/ Connector Locations	22
4.1. Top Side.....	22
4.2. Connector Panel Side	24
5/ Connector Definitions	25
6/ I/O-Area Connectors	26
6.1. DP Connector (DP1 & DP2)	26
6.2. Ethernet Connectors (CN11, CN12 & CN13)	27
6.3. USB Connectors (I/O Area).....	28
7/ Internal Connectors	30
7.1. Power Connector	30
7.1.1. Power Input Wafer (CN4).....	30
7.1.2. CR2032 Battery Power Input Wafer (BAT1).....	30
7.2. CPU Fan Wafer (FAN1).....	31
7.3. SATA (Serial ATA) Port 0, 1 Connector (SATA1 & SATA2).....	32
7.4. SATA HDD Power Output Wafer (CN1).....	33
7.5. USB Connectors (Internal) (CN5).....	34
7.6. Audio AMP Output Wafer (CN7 & CN8)	35
7.7. Audio Pin Header (CN9).....	35
7.8. Front Panel Pin Header (FP1 & FP2)	36

7.9. Serial COM1 - COM2 Ports (CN15 & CN16).....	38
7.10. Primary LVDS Panel Connector (LVDS1).....	39
7.11. Backlight Power Output Wafer (CN18).....	41
7.12. Digital Input / Output Wafer (CN10).....	42
7.13. mPCIe Socket (MPCIE1 & MPCIE2).....	43
7.14. SIM Interface Wafer for MPCIE2 (CN17).....	47
7.15. Switches and Jumpers.....	48
7.15.1. Panel & Backlight Power Selection for LVDS1 (JP1).....	48
7.15.2. AT _ATX Mode / MPCIE1 mSATA / mPCIe Selection (JP2).....	48
7.15.3. Backlight Power Enable Selection for LVDS1 (JP3).....	49
7.15.4. MPCIE Activity LED Indication (JP4).....	49
7.15.5. USB Power Selection (JP5).....	50
7.15.6. Flash Description Security Over-ride (JP6).....	50
7.15.7. RTC Reset Selection (JP7).....	51
7.15.8. SRTC Reset Selection (JP8).....	51
8/ On-Board Connectors & Mating Connector Types	52
9/ BIOS.....	53
9.1. Starting the uEFI BIOS.....	53
9.2. Setup Menus	54
9.2.1. Main Setup Menu.....	54
9.2.2. Advanced Setup Menu.....	56
9.2.3. Power Setup Menu	68
9.2.4. Boot Setup Menu.....	70
9.2.5. Security Setup Menu	71
9.2.5.1. Remember the password	72
9.2.6. Save & Exit Setup Menu.....	73
Appendix A: List of Acronyms.....	74
About Kontron	75

List of Tables

Table 1: Component Main Data	18
Table 2: Environmental Conditions	19
Table 3: Standards and Certifications	19
Table 4: Processor Support.....	20
Table 5: Memory Operating Frequencies	20
Table 6: Three-displays Configurations	21
Table 7: Supply Voltages.....	21
Table 8: Jumper List.....	22
Table 9: Top Side Internal Connector Pin Assignment.....	22
Table 10: Connector Panel Side Connector List	24
Table 11: Pin Assignment DP Connector DP1, DP2.....	26
Table 12: Pin Assignment Ethernet Connectors CN11, CN12, CN13.....	27
Table 13: Pin Assignment USB3.0 / USB2.0 Connector CN2, CN3	28
Table 14: Signal Description.....	29
Table 15: Pin Assignment CN4	30
Table 16: Pin Assignment BAT1	30
Table 17: Pin Assignment FAN1	31
Table 18: Signal description	31
Table 19: Pin Assignment SATA1, SATA2	32
Table 20: Signal Description	32

Table 21: Pin Assignment CN1.....	33
Table 22: Pin Assignment CN5	34
Table 23: Signal Description	34
Table 24: Pin Assignment CN7, CN8	35
Table 25: Pin Assignment CN9	35
Table 26: Pin Assignment FP1.....	36
Table 27: Signal Description.....	36
Table 28: Pin Assignment FP2.....	37
Table 29: Signal Description	37
Table 30: Pin Assignment CN15, CN16.....	38
Table 31: Signal Description.....	38
Table 32: Pin Assignment LVDS1	39
Table 33: Signal Description	40
Table 34: Pin Assignment CN18	41
Table 35: Signal Description	41
Table 36: Pin Assignment CN10	42
Table 37: Pin Assignment MPCIE1	43
Table 38: Pin Assignment MPCIE2	44
Table 39: Pin Assignment CN17.....	47
Table 40: Pin Assignment JP1	48
Table 41: Pin Assignment JP2	49
Table 42: Pin Assignment JP3.....	49
Table 43: Pin Assignment JP4	50
Table 44: Pin Assignment JP5.....	50
Table 45: Pin Assignment JP6.....	50
Table 46: Pin Assignment JP7.....	51
Table 47: Pin Assignment JP8.....	51
Table 48: On-Board Connectors & Mating Connector Types.....	52
Table 49: Font Size Table.....	53
Table 50: Main Setup Menu Sub-Screens and Functions	54
Table 51: List of Acronyms.....	74

List of Figures

Figure 1: System Block Diagram ECX-HSW-U	17
Figure 2: Top Side	22
Figure 3: Connector Panel Side	24
Figure 4: DP Connector DP1, DP2.....	26
Figure 5: Ethernet Connectors CN11, CN12, CN13.....	27
Figure 6: USB 3.0 Connector CN2, CN3.....	28
Figure 7: USB 2.0 High Speed Cable.....	29
Figure 8: USB 3.0 High Speed Cable.....	29
Figure 9: Power Input Wafer CN4.....	30
Figure 10: CR2032 Battery Power Input Wafer BAT1	30
Figure 11: CPU Fan Wafer FAN1.....	31
Figure 12: SATA Port 0, 1 Connector SATA1, SATA2.....	32
Figure 13: SATA HDD Power Output Wafer CN1	33
Figure 14: USB 2.0 Port 10, 11 Pin Header CN5.....	34
Figure 15: 2W Audio AMP Output Wafer CN7 (Right Channel), CN8 (Left Channel).....	35
Figure 16: Audio Pin Header CN9.....	35
Figure 17: Front Panel 1 Pin Header FP1.....	36
Figure 18: Front Panel 2 Pin Header FP2.....	36
Figure 19: Serial COM CN15, CN16	38
Figure 20: Primary LVDS Panel Connector LVDS1.....	39
Figure 21: Backlight Power Output Wafer CN18	41
Figure 22: Digital Input / Output Wafer CN10.....	42

Figure 23: mPCIe Socket MPCIE1, MPCIE2 43

Figure 24: SIM Interface Wafer CN17 47

Figure 25: Jumper Connector 48

Figure 26: Panel & Backlight Power Selection JP1 48

Figure 27: AT_ATX Mode / MPCIE1 mSATA / mPCIe Selection JP2 48

Figure 28: Backlight Power Enable Selection JP3 49

Figure 29: MPCIE Activity LED Indication JP4 49

Figure 30: USB Power Selection JP5 50

Figure 31: Flash Description Security Over-ride JP6 50

Figure 32: RTC Reset Selection JP7 51

Figure 33: SRTC Reset Selection JP8 51

Figure 34: BIOS Main Menu Screen System Data and Time 55

Figure 35: BIOS Advanced Menu 57

Figure 36: BIOS Advanced Menu - Display Configuration 58

Figure 37: BIOS Advanced Menu - Super IO Configuration 59

Figure 38: BIOS Advanced Menu - Super IO Configuration - Serial Port 1 Configuration 59

Figure 39: BIOS Advanced Menu - Super IO Configuration - Serial Port 2 Configuration 60

Figure 40: BIOS Advanced Menu - CPU Chipset Configuration 61

Figure 41: BIOS Advanced Menu - SATA Configuration 63

Figure 42: BIOS Advanced Menu - USB Configuration 64

Figure 43: BIOS Advanced Menu - Intel® Rapid Start Technology 65

Figure 44: BIOS Advanced Menu - DIO Configuration 66

Figure 45: BIOS Advanced Menu - H/W Monitor 67

Figure 46: BIOS Power Setup Menu 68

Figure 47: BIOS Power Setup Menu - WatchDog Timer Configuration 69

Figure 48: BIOS Boot Setup Menu 70

Figure 49: BIOS Boot Setup Menu 71

Figure 50: BIOS Boot Setup Menu 73

1/ Introduction

This user guide describe the ECX-HSW-U board made by Kontron. This board will also be denoted ECX-HSW-U within this user guide.

Use of this user guide implies a basic knowledge of PC-AT hardware and software. This user guide focuses on describing the ECX-HSW-U board's special features and is not intended to be a standard PC-AT textbook.

New users are recommended to study the short installation procedure stated in the following chapter before switching on the power.

All configuration and setup of the CPU board is either carried out automatically or manually by the user via the BIOS setup menus.

Latest revision of this user guide, datasheet, thermal simulations, BIOS, drivers, BSP's (Board Support Packages), mechanical drawings (2D and 3D) can be download from Kontron's Web Page.

2/ Installation Procedures

2.1. Installing the Board

NOTICE



ESD Sensitive Device

Electrostatic discharge (ESD) can damage equipment and impair electrical circuitry.

- ▶ Wear ESD-protective clothing and shoes
- ▶ Wear an ESD-preventive wrist strap attached to a good earth ground
- ▶ Check the resistance value of the wrist strap periodically (1 MΩ to 10 MΩ)
- ▶ Transport and store the board in its antistatic bag
- ▶ Handle the board at an approved ESD workstation
- ▶ Handle the board only by the edges

To get the board running follow these steps. If the board shipped from KONTRON already has components like RAM and CPU cooler mounted, then skip the relevant steps below.

1. Turn off the PSU (Power Supply Unit)

NOTICE

Turn off PSU (Power Supply Unit) completely (no mains power connected to the PSU) or leave the Power Connectors unconnected while configuring the board. Otherwise, components (RAM, LAN cards etc.) might get damaged. Make sure to use +12 V DC single supply only. Alternatively, use a standard ATX PSU with suitable cable kit and PS-ON# active.

NOTICE

The power supply unit shall comply with the requirements as defined in IEC 62368-1 according Clause 6.2.2 to power source category PS2 "Limited Power Source".

2. Insert the DDR3L 1333 / 1600 module(s)

Be careful to push the memory module(s) in the slot(s) before locking the tabs.

3. Connecting interfaces

Insert all external cables for hard disk, keyboard etc. A monitor must be connected in order to change BIOS settings.

4. Connect and turn on PSU

Connect PSU to the board by the +12 V 3.0mm pitch 1x4-pin wafer connector.

5. BIOS setup

Enter the BIOS setup by pressing the key during boot up.

Enter "Exit Menu" and Load Setup Defaults.



To clear all BIOS setting, including Password protection, activate "Clear CMOS Jumper" for 10 sec (without power connected).

6. Mounting the board in chassis

NOTICE

When mounting the board to chassis etc. please note that the board contains components on both sides of the PCB that can easily be damaged if board is handled

without reasonable care. A damaged component can result in malfunction or no function at all.

When fixing the board on a chassis, it is recommended to use screws with an integrated washer and a diameter of > 7 mm. Do not use washers with teeth, as they can damage the PCB and cause short circuits.

2.2. Chassis Safety Standards

Before installing the ECX-HSW-U in the chassis, users must evaluate the end product to ensure compliance with the requirements of the IEC60950-1 safety standard:

- ▶ The board must be installed in a suitable mechanical, electrical and fire enclosure.
- ▶ The system, in its enclosure, must be evaluated for temperature and airflow considerations.
- ▶ The board must be powered by a CSA or UL approved power supply that limits the maximum input current.
- ▶ For interfaces having a power pin such as external power or fan, ensure that the connectors and wires are suitably rated. All connections from and to the product shall be with SELV circuits only.
- ▶ Wires have suitable rating to withstand the maximum available power.
- ▶ The peripheral device enclosure fulfils the IEC60950-1 fire protecting requirements.

2.3. Lithium Battery Replacement

If replacing the lithium battery follow the replacement precautions stated in the notification below:

⚠ CAUTION

Danger of explosion if the lithium battery is incorrectly replaced.

- ▶ Replace only with the same or equivalent type recommended by the manufacturer
- ▶ Dispose of used batteries according to the manufacturer's instructions

VORSICHT! Explosionsgefahr bei unsachgemäßem Austausch der Batterie.

- ▶ Ersatz nur durch denselben oder einen vom Hersteller empfohlenen gleichwertigen Typ
- ▶ Entsorgung gebrauchter Batterien nach Angaben des Herstellers

ATTENTION! Risque d'explosion avec l'échange inadéquat de la batterie.

- ▶ Remplacement seulement par le même ou un type équivalent recommandé par le producteur
- ▶ L'évacuation des batteries usagées conformément à des indications du fabricant

PRECAUCION! Peligro de explosi3n si la bater3a se sustituye incorrectamente.

- ▶ Sustituya solamente por el mismo o tipo equivalente recomendado por el fabricante
- ▶ Disponga las bater3as usadas seg3n las instrucciones del fabricante

ADVARSEL! Lithiumbatteri – Eksplosjonsfare ved feilagtig h3ndtering.

- ▶ Udsiftning m3 kun ske med batteri af samme fabrikat og type
- ▶ Lev3r det brugte batteri tilbage til leverand3ren

ADVARSEL! Eksplosjonsfare ved feilaktig skifte av batteri.

- ▶ Benytt samme batteritype eller en tilsvarende type anbefalt av apparatfabrikanten
- ▶ Brukte batterier kasseres i henhold til fabrikantens instruksjoner

WARNING! Explosionsfara vid felaktigt batteribyte.

- ▶ Anv3nd samma batterityp eller en ekvivalent typ som rekommenderas av apparattillverkaren
 - ▶ Kassera anv3nt batteri enligt fabrikantens instruktion
-

VAROITUS! Paristo voi räjähtää, jos se on virheellisesti asennettu.

- ▶ Vaihda paristo ainoastaan lalteval- mistajan suosittelemaan tyyppiln
 - ▶ Hävitä käytetty paristo valmistajan ohjeiden mukaisesti
-

3/ System Specifications

3.1. System Block Diagram

Figure 1: System Block Diagram ECX-HSW-U

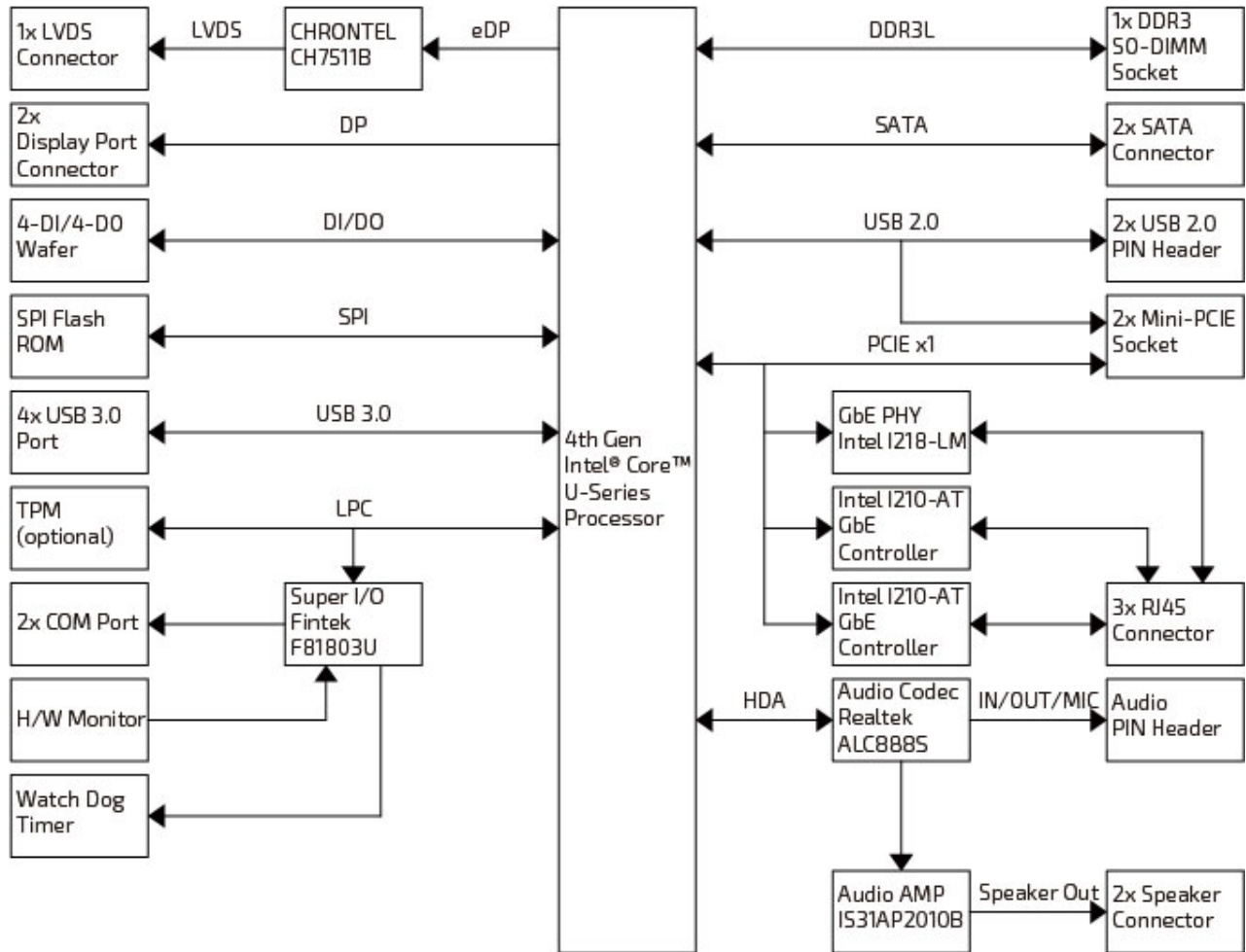

3.2. Component Main Data

The table below summarizes the features of the ECX-HSW-U single board computer.

Table 1: Component Main Data

System	
Processor	4th Generation Intel® Core™ U-Series Processors
Memory	1x DDR3L SO-DIMM memory socket
Video	
Display Interface	<ul style="list-style-type: none"> ▶ 1x LVDS (18/24-bit, 1/2-ch) ▶ 2x DP (on rear, 3200 x 2000 @ 60 Hz)
Multiple Display	Triple
Audio	
Audio Codec	Realtek ALC8885
Audio Interface	<ul style="list-style-type: none"> ▶ 2x Speaker-out (3 W) ▶ 1x Line-in (by header) ▶ 1x Line-out (by header) ▶ 1x Mic-in (by header)
Network Connection	
Ethernet	<ul style="list-style-type: none"> ▶ 3x GbE LAN (RJ45 on rear, 2x Intel® I210-AT, 1x Intel® I218-LM) ▶ LAN1 shared with half-sized mPCIe and enabled by default
Peripheral Connection	
USB	<ul style="list-style-type: none"> ▶ 4x USB 3.0 (Type A on rear) ▶ 2x USB 2.0 (by header)
Serial Port	▶ 2x RS232/422/485 (by header)
Other I/Os	▶ 1x 8-bit DIO (by header)
Storage & Expansion	
Storage & Expansion	<ul style="list-style-type: none"> ▶ 2x SATA 3.0 ▶ 1x mSATA / mPCIe (full size) ▶ 1x mPCIe (half size, shared with LAN1 and disabled by default) ▶ 1x SIM Card Cage (by wafer)
Power	
Input Voltage	DC 12 V
Connector	1x 4-pin pitch 3.0 mm Wafer
Firmware	
BIOS	AMI uEFI BIOS w/ 128 Mb SPI Flash
Watchdog	Programmable WDT to generate system reset event
H/W Monitor	Voltages, Temperatures
Real Time Clock	Processor integrated RTC
TPM	Supported for models w/ Core™ i7 / i5 (Infineon SLB 9635 TPM 1.2)
iAMT	Supported for models w/ Core™ i7 / i5
System Control & Monitoring	

FP Header	<ul style="list-style-type: none"> ▶ 1x Header for Reset button, HDD LED & External Speaker ▶ 1x Header for Power button, Power LED & SM bus ▶ 1x Header for mPCIe activity LED
Cooling	
FAN	1x Wafer for CPU Smart Fan
Software	
OS Support	Windows 7, Windows 8, Linux
Mechanical	
Dimension (L x W)	3.5" ECX (146 mm x 105 mm / 5.75" x 4.13")

3.3. Environmental Conditions

The ECX-HSW-U is compliant with the following environmental conditions. It is the customer's responsibility to provide sufficient airflow around each of the components to keep them within the allowed temperature range.

Table 2: Environmental Conditions

Operating Temperature	0 °C ~ 60 °C / 32 °F ~ 140 °F (Standard) -20 °C ~ 70 °C / -4 °F ~ 158 °F (Extended)
Storage Temperature	-20 °C ~ 80 °C / -4 °F ~ 176 °F (Standard) -40 °C ~ 85 °C / -40 °F ~ 185 °F (Extended)
Humidity	0 % ~ 95 %

3.4. Standards and Certifications

The ECX-HSW-U meets the following standards and certification tests.

Table 3: Standards and Certifications

CE	<ul style="list-style-type: none"> ▶ EN 55022: 2010 + AC: 2011 Class A ▶ EN 55024: 2010 ▶ EN 61000-3-2: 2006 + A1: 2009 + A2: 2009 Class D ▶ EN 61000-3-3: 2013 ▶ EN 60950-1: 2006 + A11: 2009 + A1: 2010 + A12: 2011 + A2: 2013 ▶ IEC 60950-1: 2005 (Second Edition) + Am 1: 2009 + Am 2: 2013
FCC	<ul style="list-style-type: none"> ▶ FCC CFR Title 47 Part 15 Subpart B: 2014 ▶ ANSI C63.4-2009 ▶ ICES-003 Issue 5: 2012 ▶ CISPR 22: 2008 ▶ CAN/CSA-CISPR 22-10

3.5. Processor Support

The ECX-HSW-U is designed to support 4th Generation Intel® Core™ U-Series Processors. The BGA CPU is remounted from factory. Kontron has defined the board versions as listed in the following table, so far all based on Embedded CPUs. Other versions are expected at a later date.

Table 4: Processor Support

Name	Core #	Speed	Turbo	Embedded	Cache	Socket	TDP	Tj
Core™ i3-4010U	2	1.70 GHz	-	Yes	3M	FCBGA1168	15 W	100 °C
Core™ i5-4300U	2	1.90 GHz	2.90 GHz	Yes	3M	FCBGA1168	15 W	100 °C
Core™ i7-4650U	2	1.70 GHz	3.30 GHz	Yes	3M	FCBGA1168	15 W	100 °C

Sufficient cooling must be applied to the CPU in order to remove the effect as listed as TDP (Thermal Design Power) in above table. The sufficient cooling is also depending on the worst case maximum ambient operating temperature and the actual worst case load of processor.

3.6. System Memory Support

The ECX-HSW-U has one DDR3L SO-DIMM socket. The socket supports the following memory features:

- ▶ 1x DDR3L SO-DIMM 204-pin
- ▶ Up to 8GB
- ▶ SPD timing supported
- ▶ ECC not supported

The installed DDR3L SO-DIMM should support the Serial Presence Detect (SPD) data structure. This allows the BIOS to read and configure the memory controller for optimal performance. If non-SPD memory is used, the BIOS will attempt to configure the memory settings, but performance and reliability may be impacted, or the board may not be able to boot totally.

3.6.1. Memory Operating Frequencies

In all modes, the frequency of system memory is the lowest frequency of all the memory modules placed in the system. Each memory module's frequency can be determined through the SPD registers on the memory modules.

The table below lists the resulting operating memory frequencies based on the combination of SO-DIMMs and processor.

Table 5: Memory Operating Frequencies

SO-DIMM Type	Module Name	Memory Data Transfer (MT/s)	Processor System Bus Frequency (MHz)	Resulting Memory Clock Frequency (MHz)	Peak Transfer Rate (MB/s)
DDR3L 1333	PC3-10600	1333	667	167	10667
DDR3L 1600	PC3-12800	1600	800	200	12800

Memory modules have in general a much lower longevity than embedded motherboards, and therefore EOL of modules can be expected several times during lifetime of the motherboard.

As a minimum it is recommend using Kontron memory modules for prototype system(s) in order to prove stability of the system and as for reference.

For volume production you might request to test and qualify other types of RAM. In order to qualify RAM it is recommend configuring 3 systems running RAM Stress Test program in heat chamber at 60° C for a minimum of 24 hours.

3.7. On-board Graphics Subsystem

The ECX-HSW-U supports Intel® HD Graphics technology for high quality graphics capabilities. All ECX-HSW-U versions support three displays pipes.

Three displays can be used simultaneously and be used to implement independent or cloned display configuration.

Table 6: Three-displays Configurations

Display 1	Display 2	Display	Max. Resolution (Px) at 60 Hz		
			Display 1	Display 2	Display 3
LVDS	DP	DP	1920x1200	3200x2000	3200x2000

3.8. Power Supply

In order to ensure safe operation of the board, the input power supply must monitor the supply voltage and shut down if the supply is out of range – refer to the actual power supply specification. Please note, in order to keep the power consumption to a minimal level, boards do not implement a guaranteed minimum load. In some cases, this can lead to compatibility problems with ATX power supplies that require a minimum load to stay in regulation. The ECX-HSW-U board must be powered through the ATX+12V-4p (4-pole) connector using standard ATX power supply.

ATX12V supply: ATX+12V-4p connector must be used in according to the ATX12V PSU standard.

NOTICE

Hot Plugging power supply is not supported. Hot plugging might damage the board.

The requirements to the supply voltages are as follows:

Table 7: Supply Voltages

Supply	Min.	Max.	Note
+12 V	11.4 V	12.6 V	Should be ±5% for compliance with the ATX specification

4/ Connector Locations

4.1. Top Side

Figure 2: Top Side

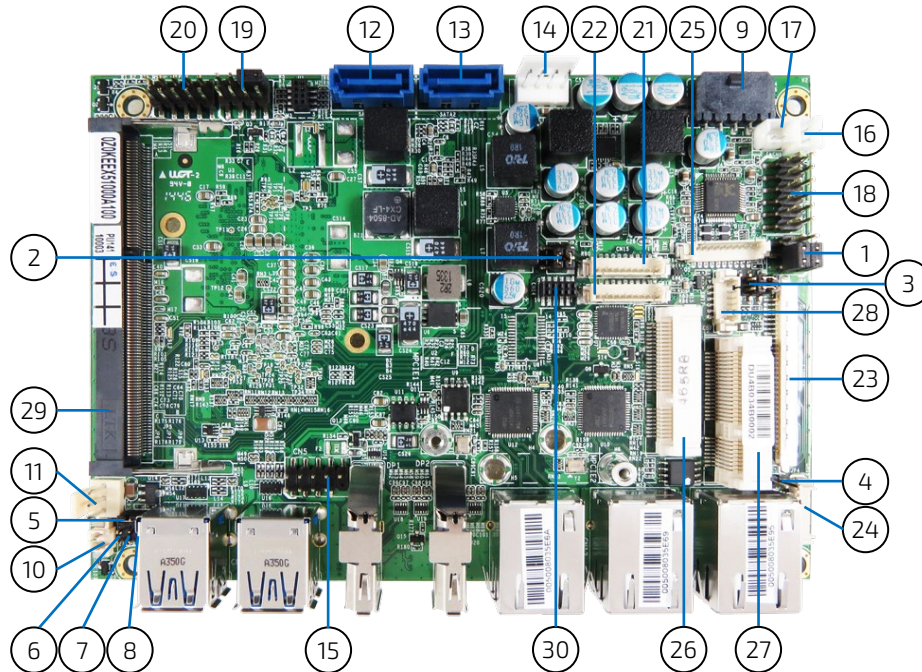

Table 8: Jumper List

Item	Designation	Description	See Chapter
1	JP1	Panel & Backlight Power Selection for LVDS1	7.17.1
2	JP2	AT_ATX Mode / MPCIE1 mSATA / mPCIE Selection	7.17.2
3	JP3	Backlight Power Enable Selection for LVDS1	7.17.3
4	JP4	MPCIE Activity LED Indication	7.17.4
5	JP5	USB Power Selection	7.17.5
6	JP6	Flash Description Security Over-ride	7.17.6
7	JP7	RTC Reset Selection	7.17.7
8	JP8	SRTC Reset Selection	7.17.8

Table 9: Top Side Internal Connector Pin Assignment

Item	Designation	Description	See Chapter
9	CN4	Power Input Wafer	7.1.1
10	BAT1	CR2032 Battery Power Input Wafer	7.1.2
11	FAN1	CPU FAN Wafer	7.2
12	SATA1	Serial ATA Port 0 Connector	7.3
13	SATA2	Serial ATA Port 1 Connector	7.3
14	CN1	SATA HDD Power Output Wafer	7.4
15	CN5	USB 2.0 Port 10, 11 Pin Header	7.5
16	CN7	Right Channel 2W Audio AMP Output Wafer	7.6

Item	Designation	Description	See Chapter
17	CN8	Left Channel 2W Audio AMP Output Wafer	7.6
18	CN9	Audio Pin Header	7.7
19	FP1	Front Panel 1 Pin Header	7.8
20	FP2	Front Panel 2 Pin Header	7.8
21	CN15	RS232/422/485 Port 1 Wafer	7.9
22	CN16	RS232/422/485 Port 2 Wafer	7.9
23	LVDS1	Primary LVDS Panel Connector	7.10
24	CN18	Backlight Power Output Wafer for LVDS1	7.11
25	CN10	Digital Input / Output Wafer	7.12
26	MPCIE1	Mini-PCIE Express v1.2 Socket (Full Size)	7.13
27	MPCIE2	Mini-PCIE Express v1.2 Socket (Half Size)	7.13
28	CN17	SIM Interface Wafer for MPCIE2	7.14
29	DIMM1	DDR3 Memory SO-DIMM Socket	3.6
30	CN14	P80 Header	

4.2. Connector Panel Side

Figure 3: Connector Panel Side

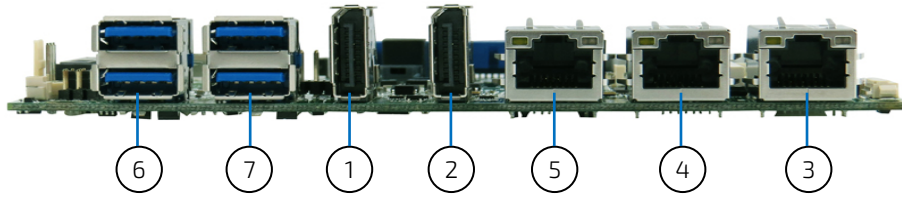

Table 10: Connector Panel Side Connector List

Item	Designation	Description	See Chapter
1	DP1	DP Connector	6.1
2	DP2	DP Connector	6.1
3	CN11	GbE LAN1 RJ45 Connector	6.2
4	CN12	GbE LAN2 RJ45 Connector	6.2
5	CN13	GbE LAN3 RJ45 Connector	6.2
6	CN2	USB3.0 Port 0,1 Connector	6.3
7	CN3	USB3.0 Port 2,3 Connector	6.3

5/ Connector Definitions

The following defined terms are used within this user guide to give more information concerning the pin assignment and to describe the connector's signals.

Defined Term	Description
Pin	Shows the pin numbers in the connector
Signal	The abbreviated name of the signal at the current pin The notation "XX#" states that the signal "XX" is active low
Note	Special remarks concerning the signal
Designation	Type and number of item described
See Chapter	Number of the chapter within this user guide containing a detailed description

The abbreviation TBD is used for specifications that are not available yet or which are not sufficiently specified by the component vendors.

6/ I/O-Area Connectors

6.1. DP Connector (DP1 & DP2)

The DP (DisplayPort) connectors are based on standard DP female port.

Figure 4: DP Connector DP1, DP2

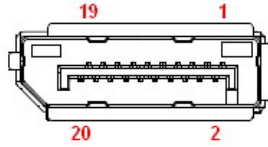

Table 11: Pin Assignment DP Connector DP1, DP2

Pin	Signal	Description	Note
1	TX0+		
2	GND		
3	TX0-		
4	TX1+		
5	GND		
6	TX1-		
7	TX2+		
8	GND		
9	TX2-		
10	TX3+		
11	GND		
12	TX3-		
13	GND		
14	GND		
15	AUX+		
16	GND		
17	AUX-		
18	HPD		
19	GND		
20	PWR		

6.2. Ethernet Connectors (CN11, CN12 & CN13)

The ECX-HSW-U supports three channels of 10/100/1000 Mbit Ethernet, which are based Intel® I218-LM (LAN1 (CN11)) and Intel® I210-AT (LAN2 (CN12) & LAN3 (CN13)) controllers respectively. LAN1 (CN11) is shared with half-sized mPCIe (MPCIE2) and is enabled by default.

In order to achieve the specified performance of the Ethernet port, Category 5 twisted pair cables must be used with 10/100 MByte and Category 5E, 6 or 6E with 1 Gbit LAN networks.

The signals for the Ethernet ports are as follows:

Figure 5: Ethernet Connectors CN11, CN12, CN13

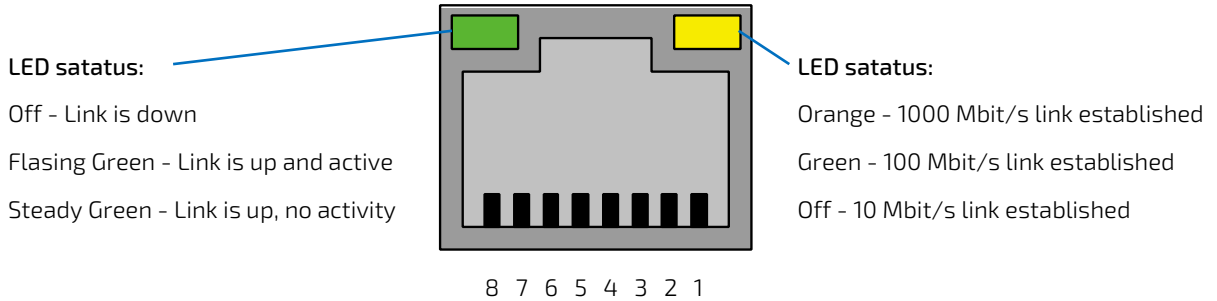

Table 12: Pin Assignment Ethernet Connectors CN11, CN12, CN13

Pin	Signal	Note
1	TX1+	
2	TX1-	
3	TX2+	
4	TX3+	
5	TX3-	
6	TX2-	
7	TX4+	
8	TX4-	

Signal Description

Signal	Description
TX1+ / TX1-	In MDI mode, this is the first pair in 1000Base-T, i.e. the BI_DA+/- pair, and is the transmit pair in 10Base-T and 100Base-TX. In MDI crossover mode, this pair acts as the BI_DB+/- pair, and is the receive pair in 10Base-T and 100Base-TX.
TX2+ / TX2-	In MDI mode, this is the second pair in 1000Base-T, i.e. the BI_DB+/- pair, and is the receive pair in 10Base-T and 100Base-TX. In MDI crossover mode, this pair acts as the BI_DA+/- pair, and is the transmit pair in 10Base-T and 100Base-TX.
TX3+ / TX3-	In MDI mode, this is the third pair in 1000Base-T, i.e. the BI_DC+/- pair. In MDI crossover mode, this pair acts as the BI_DD+/- pair.
TX4+ / TX4-	In MDI mode, this is the fourth pair in 1000Base-T, i.e. the BI_DD+/- pair. In MDI crossover mode, this pair acts as the BI_DC+/- pair.

'MDI' – media dependent Interface

6.3. USB Connectors (I/O Area)

The external I/O connector panel supports two dual USB 3.0 connectors.



USB3.0 ports are backward compatible with USB2.0.

Figure 6: USB 3.0 Connector CN2, CN3

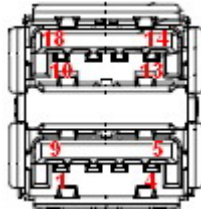

Table 13: Pin Assignment USB3.0 / USB2.0 Connector CN2, CN3

Pin	Signal	Note
Top		
18	USBB_TX+	USB 3.0 Tx. Differential Pair (+)
17	USBB_TX-	USB 3.0 Tx. Differential Pair (-)
16	GND	
15	USBB_RX+	USB 3.0 Tx. Differential Pair (+)
14	USBB_RX-	USB 3.0 Tx. Differential Pair (-)
13	GND	
12	USBB_D-	USB 2.0 Differential Pair (+)
11	USBB_D-	USB 2.0 Differential Pair (-)
10	+USBB_VCC*	+5 V Supply for USB device
Bottom		
9	USBA_TX+	USB 3.0 Tx. Differential Pair (+)
8	USBA_TX-	USB 3.0 Tx. Differential Pair (-)
7	GND	
6	USBA_RX+	USB 3.0 Tx. Differential Pair (+)
5	USBA_RX-	USB 3.0 Tx. Differential Pair (-)
4	GND	
3	USBA_D-	USB 2.0 Differential Pair (+)
2	USBA_D-	USB 2.0 Differential Pair (-)
1	+USBA_VCC*	+5 V Supply for USB device



* The power source of +USBVCC can be selected by JP5.

Table 14: Signal Description

Signal	Description
USBn_TX+, USBn_TX-, USBn_RX+, USBn_RX-, USBn_D-, USBn_D-	Differential pair works as serial differential receive/transmit data lines. (n= A, B)
+USBn_VCC	5 V supply for external devices. VCC is supplied during power-down to allow wakeup on USB device activity. Protected by a 1A current limiting IC covering each of the USB port. (n= A, B)

For HiSpeed rates it is required to use a USB cable, which is specified in USB 2.0 standard:

Figure 7: USB 2.0 High Speed Cable

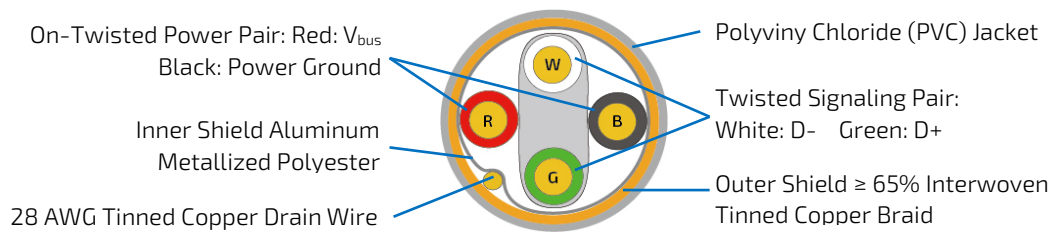

For USB 3.0 cabling it is required to use only HiSpeed USB cable, specified in USB3.0 standard:

Figure 8: USB 3.0 High Speed Cable

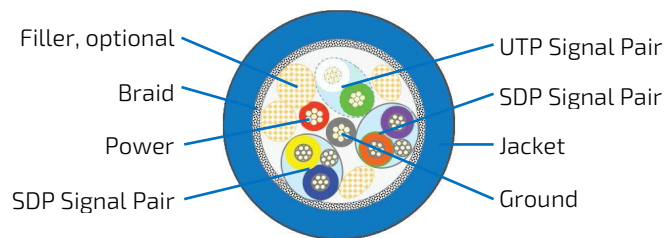

7/ Internal Connectors

7.1. Power Connector

Power connector must be used to supply the board with +12 VDC ($\pm 10\%$).

NOTICE

Hot plugging any of the power connector is not allowed.

Hot plugging might damage the board. In other words, turn off main supply etc. to make sure all the power lines are turned off when connecting to the motherboard.

7.1.1. Power Input Wafer (CN4)

Figure 9: Power Input Wafer CN4

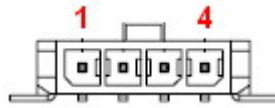

Table 15: Pin Assignment CN4

Pin	Signal	Description
1	+Vin	Power +12 V
2	GND	Ground
3	GND	Ground
4	+Vin	Power +12 V

7.1.2. CR2032 Battery Power Input Wafer (BAT1)

Figure 10: CR2032 Battery Power Input Wafer BAT1



Table 16: Pin Assignment BAT1

Pin	Signal	Description
1	+VBAT	
2	GND	

7.2. CPU Fan Wafer (FAN1)

The CPU Fan Wafer (FAN1) is used for the connection of the Fan for the CPU.

Figure 11: CPU Fan Wafer FAN1

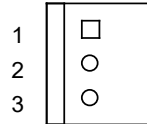

Table 17: Pin Assignment FAN1

Pin	Signal	Description
1	GND	Ground
2	+12V*	Power +12V*
3	FAN_RPM	Rotations Per Minute of the FAN



* It supports PWM (Pulse Width Modulation) Fan control.

Table 18: Signal description

Signal	Description
GND	Power Supply GND signal
+12V	+12 V supply for fan
FAN_RPM	Sense input signal from the fan, for rotation speed supervision RPM (Rotations Per Minute). The signal shall be generated by an open collector transistor or similar.

7.3. SATA (Serial ATA) Port 0, 1 Connector (SATA1 & SATA2)

The SATA connectors supply the data connection for the SATA hard disk and is SATA 3.0 compatible.

Figure 12: SATA Port 0, 1 Connector SATA1, SATA2

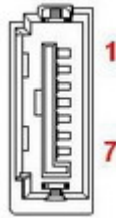

Table 19: Pin Assignment SATA1, SATA2

Pin	Signal	Note
1	GND	
2	TX+	
3	TX-	
4	GND	
5	RX-	
6	RX+	
7	GND	

Table 20: Signal Description

Signal	Description
RX+ / RX-	Host transmitter differential signal pair
TX+ / TX-	Host receiver differential signal pair

7.4. SATA HDD Power Output Wafer (CN1)

Figure 13: SATA HDD Power Output Wafer CN1

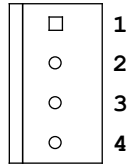

Table 21: Pin Assignment CN1

Pin	Signal	Note
1	+12V	
2	GND	
3	GND	
4	+5V	

7.5. USB Connectors (Internal) (CN5)

The USB port pin header CN5 supports two USB 2.0 ports.

Figure 14: USB 2.0 Port 10, 11 Pin Header CN5

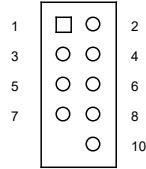

Table 22: Pin Assignment CN5

Pin	Signal	Note
1	+USBVCC	
2	+USBVCC	
3	USB_A-	
4	USB_B-	
5	USB_A+	
6	USB_B+	
7	GND	
8	GND	
9	KEY	
10	GND	



The power source of +USBVCC can be selected by JP7.

Table 23: Signal Description

Signal	Description
+USBVCC	5 V supply for external devices. SB5V is supplied during power down to allow wakeup on USB device activity. Protected by active power switch 1 A fuse for each USB port.
USB_A-/+ USB_B-/+	Universal Serial Bus Differentials: Bus Data / Address / Command Bus.

7.6. Audio AMP Output Wafer (CN7 & CN8)

The Speaker audio-out interface is available through the wafers CN7 and CN8. These outputs are shared with the audio output (Line-out) signals of the audio pin header CN9.

Figure 15: 2W Audio AMP Output Wafer CN7 (Right Channel), CN8 (Left Channel)

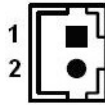

Table 24: Pin Assignment CN7, CN8

Pin	Signal	Note
1	Speaker+	
2	Speaker-	

7.7. Audio Pin Header (CN9)

The audio pin header provides audio output (Line-Out), audio input (Line-In) and microphone (Mic-In) signals through the wafer CN9. The audio output signals are shared with those of the speaker connectors CN7 & CN8.

Figure 16: Audio Pin Header CN9

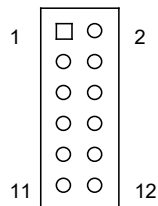

Table 25: Pin Assignment CN9

Pin	Signal	Note
1	MIC-In_L	
2	MIC-In_R	
3	MIC-In_JD	
4	GND	
5	Line-In_L	
6	Line-In_R	
7	Line-In_JD	
8	GND	
9	Line-Out_L	
10	Line-Out_R	
11	Line-Out_JD	

Pin	Signal	Note
12	GND	

7.8. Front Panel Pin Header (FP1 & FP2)

Figure 17: Front Panel 1 Pin Header FP1

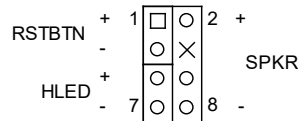

Table 26: Pin Assignment FP1

Pin	Signal	Note
1	Reset Button +	
2	Speaker +	
3	Reset Button -	
4	NC	
5	HDD LED +	
6	Internal Speaker -	
7	HDD LED -	
8	Speaker -	



Internal Buzzer is enabled when Pin6-8 is shorted.

Table 27: Signal Description

Signal	Description
Reset Button -/+	Reset Button. This 2-pin connector is for chassis mounted reset button for system reboot without turning off the system power.
HDD LED -/+	Hard Disk Drive Activity LED. This 2-pin connector is for HDD Activity LED. Connect the HDD Activity LED cable to this connector. The HDD LED lights up or flashes when data is read from or written to the HDD.
Internal Speaker - Speaker -/+	System warning speaker. The speaker allows user to hear beeps and warnings.

Figure 18: Front Panel 2 Pin Header FP2

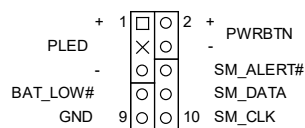

Table 28: Pin Assignment FP2

Pin	Signal	Note
1	Power LED +	
2	Power Button +	
3	NC	
4	Power Button -	
5	Power LED -	
6	SMBALERT#	
7	BATLOW#	
8	SMBus Data	
9	GND	
10	SMBus Clock	

Table 29: Signal Description

Signal	Description
Power LED - /+	System Power LED. The power LED lights up when users turn on the system power, and blinks when the system is in sleep mode.
Power Button -/+	The 2-pin connector is for the system power button. Pressing the power button turns the system on or puts the system in sleep or soft-off mode depending on the operating system settings. Pressing the power switch for more than four seconds while the system turns from ON to OFF.
SMBALERT#	System Management Bus Alert
SMBus Data	System Management Bus bidirectional data line
SMBus Clock	System Management Bus bidirectional clock line
BATLOW#	Battery low input. This signal may be driven low by external circuitry to signal that the system battery is low. It also can be used to signal some other external power management event.

7.9. Serial COM1 - COM2 Ports (CN15 & CN16)

Figure 19: Serial COM CN15, CN16

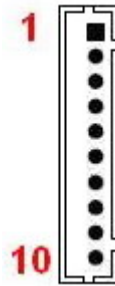

Table 30: Pin Assignment CN15, CN16

Pin	RS232 Signal	RS422 Signal	Half Duplex RS485 Signal	Full Duplex RS485 Signal	Note
1	DCD	TX-	DATA-	TX-	
2	DSR	TX+	DATA+	TX+	
3	RXD	RX+	N/A	RX+	
4	RTS	RX-	N/A	RX-	
5	TXD	N/A	N/A	N/A	
6	CTS	N/A	N/A	N/A	
7	DTR	N/A	N/A	N/A	
8	RI	N/A	N/A	N/A	
9	GND	GND	GND	GND	
10	+5V	+5V	+5V	+5V	



The COM ports need to install an OS patch from ITE. The patch is only available for Windows and is not available Linux.

Table 31: Signal Description

Signal	Description
TXD	Transmitted Data, sends data to the communications link. The signal is set to the marking state (-12 V) on hardware reset when the transmitter is empty or when loop mode operation is initiated.
RXD	Received Data, receives data from the communications link.
DTR	Data Terminal Ready, indicates to the modem etc. that the on-board UART is ready to establish communication link.
DSR	Data Set Ready, indicates that the modem etc. is ready to establish a communications link.
RTS	Request To Send, indicates to the modem etc. that the on-board UART is ready to exchange data.
CTS	Clear To Send, indicates that the modem or data set is ready to exchange data.
DCD	Data Carrier Detect, indicates that the modem or data set has detected the data carrier.
RI	Ring Indicator, indicates that the modem has received a ringing signal from the telephone line.
TX+/-	Transmitted Data differential pair sends data to the communications link.

Signal	Description
RX+/-	Received Data differential pair receives data from the communications link.
GND	Power Supply GND signal

7.10. Primary LVDS Panel Connector (LVDS1)

The primary 18/24-bit, 1/2-channel LVDS connector is based on 30-pole connector type JAE FI-X30SSL-HF.

Figure 20: Primary LVDS Panel Connector LVDS1

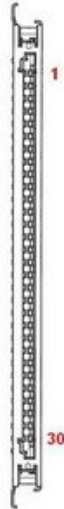

Table 32: Pin Assignment LVDS1

Pin	Signal	Note
1	LVDS_A0-	
2	LVDS_A0+	
3	LVDS_A1-	
4	LVDS_A1+	
5	LVDS_A2-	
6	LVDS_A2+	
7	GND	
8	LVDS_ACLK-	
9	LVDS_ACLK+	
10	LVDS_A3-/NC	
11	LVDS_A3+/NC	
12	LVDS_B0-	
13	LVDS_B0+	
14	GND	
15	LVDS_B1-	
16	LVDS_B1+	
17	GND	

Pin	Signal	Note
18	LVDS_B2-	
19	LVDS_B2+	
20	LVDS_BCLK-	
21	LVDS_BCLK+	
22	LVDS_B3-/NC	
23	LVDS_B3+/NC	
24	GND	
25	DDC_DATA	
26	VDDEN	
27	DDC_CLK	
28	+3.3V / +5V *	
29	+3.3V / +5V*	
30	+3.3V / +5V*	



* Panel Power can be selected by JP1.

Table 33: Signal Description

Signal	Description
LVDS_A0..A3	LVDS A Channel data
LVDS_ACLK	LVDS A Channel clock
LVDS_B0..B3	LVDS B Channel data
LVDS_BCLK	LVDS B Channel clock
VDDEN	Output Display Enable
DDC_DATA	DDC channel Data
DDC_CLK	DDC Channel Clock

7.11. Backlight Power Output Wafer (CN18)

Figure 21: Backlight Power Output Wafer CN18



Table 34: Pin Assignment CN18

Pin	Signal	Note
1	BL_ADJ_PWM*	
2	BL_ADJ_VOL*	
3	GND	
4	+5V / +12V**	
5	+5V / +12V**	
6	GND	
7	BL_EN***	



* BL_ADJ can be setting in BIOS setup.



** Backlight Power can be selected by JP1.



*** BL_EN can be selected by JP3.

Table 35: Signal Description

Signal	Description
BL_ADJ_PWM	Backlight Adjustment PWM (Pulse Width Modulation) signal
BL_ADJ_VOL	Backlight Adjustment Voltage signal
BL_EN	Backlight Enable signal

7.12. Digital Input / Output Wafer (CN10)

Figure 22: Digital Input / Output Wafer CN10

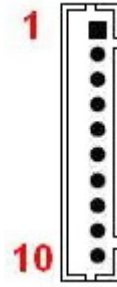

Table 36: Pin Assignment CN10

Pin	Signal	Note
1	+5V	
2	Digital Input 0	
3	Digital Output 0	
4	Digital Input 1	
5	Digital Output 1	
6	Digital Input 2	
7	Digital Output 2	
8	Digital Input 3	
9	Digital Output 3	
10	GND	

7.13. mPCIe Socket (MPCIE1 & MPCIE2)

Full-sized Mini-PCI Express V1.2 socket (MPCIE1) and half-sized Mini-PCI Express V1.2 socket (MPCIE2). Socket MPCIE1 supports mPCIe, mSATA and USB2.0 while Socket MPCIE2 supports mPCIe, USB 2.0 and SIM-card socket. The SIM-card socket makes it possible to use a 3G/4G-wireless modem in this mPCIe slot. The USB does support WAKE function.

Figure 23: mPCIe Socket MPCIE1, MPCIE2

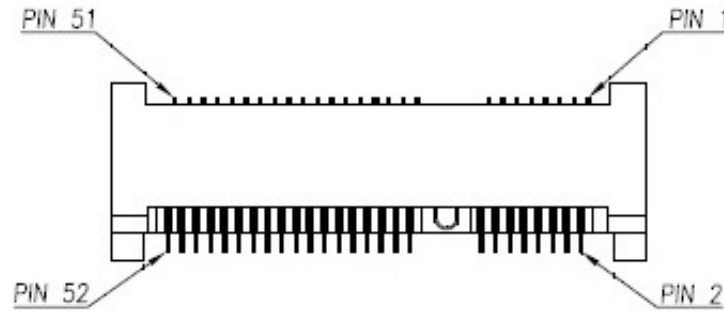

Table 37: Pin Assignment MPCIE1

Pin	Signal	Note
1	WAKE#	
2	+3.3VSB	
3	Reserved	
4	Ground	
5	Reserved	
6	+1.5V	
7	CLKREQ#	
8	NC	
9	Ground	
10	NC	
11	REFCLK-	
12	NC	
13	REFCLK+	
14	NC	
15	Ground	
16	NC	
17	Reserved	
18	Ground	
19	Reserved	
20	W_Disable#	
21	Ground	
22	PERST#	
23	PERn0	
24	+3.3VSB	
25	PERp0	

Pin	Signal	Note
26	Ground	
27	Ground	
28	+1.5V	
29	Ground	
30	SMB_CLK	
31	PETn0	
32	SMB_DATA	
33	PETp0	
34	Ground	
35	Ground	
36	USB_D-	
37	Ground	
38	USB_D+	
39	+3.3VSB	
40	Ground	
41	+3.3VSB	
42	LED_WWAN#	
43	Ground	
44	LED_WLAN#	
45	Reserved	
46	LED_WPAN#	
47	Reserved	
48	+1.5V	
49	Reserved	
50	Ground	
51	Reserved	
52	+3.3VSB	

Table 38: Pin Assignment MPCIE2

Pin	Signal	Note
1	WAKE#	
2	+3.3VSB	
3	Reserved	
4	Ground	
5	Reserved	
6	+1.5V	
7	CLKREQ#	
8	UIM_PWR*	
9	Ground	
10	UIM_DATA*	
11	REFCLK-	
12	UIM_CLK*	

Pin	Signal	Note
13	REFCLK+	
14	UIM_RESET*	
15	Ground	
16	UIM_VPP*	
17	Reserved	
18	Ground	
19	Reserved	
20	W_Disable#	
21	Ground	
22	PERST#	
23	PERn0	
24	+3.3VSB	
25	PERp0	
26	Ground	
27	Ground	
28	+1.5V	
29	Ground	
30	SMB_CLK	
31	PETn0	
32	SMB_DATA	
33	PETp0	
34	Ground	
35	Ground	
36	USB_D-	
37	Ground	
38	USB_D+	
39	+3.3VSB	
40	Ground	
41	+3.3VSB	
42	LED_WWAN#	
43	Ground	
44	LED_WLAN#	
45	Reserved	
46	LED_WPAN#	
47	Reserved	
48	+1.5V	
49	Reserved	
50	Ground	
51	Reserved	
52	+3.3VSB	



* These pins are connected to CN17 SIM Interface directly.



MPCIE2 is shared with CN11 GbE LAN1 and disabled by default.

7.14. SIM Interface Wafer for MPCIE2 (CN17)

Figure 24: SIM Interface Wafer CN17



Table 39: Pin Assignment CN17

Pin	Signal	Description	Note
1	UIM_PWR	Power +5V or +3.3V	
2	UIM_DATA	Input or Output for serial data	
3	UIM_RESET	Reset signal	
4	UIM_VPP	Programming voltage input	
5	UIM_CLK	Clock signal	
6	GND	Ground	

7.15. Switches and Jumpers

The product has several jumpers which must be properly configured to ensure correct operation.

Figure 25: Jumper Connector

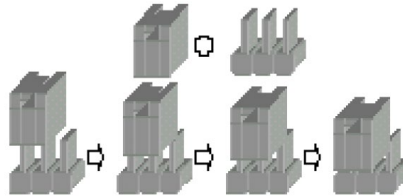

For a three-pin jumper (see Figure 25), the jumper setting is designated "1-2" when the jumper connects pins 1 and 2. The jumper setting is designated "2-3" when pins 2 and 3 are connected and so on. You will see that one of the lines surrounding a jumper pin is thick, which indicates pin No.1.

To move a jumper from one position to another, use needle-nose pliers or tweezers to pull the pin cap off the pins and move it to the desired position.

7.15.1. Panel & Backlight Power Selection for LVDS1 (JP1)

Figure 26: Panel & Backlight Power Selection JP1

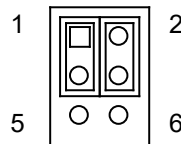

Table 40: Pin Assignment JP1

Jumper 1 Position		Description
Pin 1-3	Pin 3-5	
X	-	Backlight Power = +12V
-	X	Backlight Power = +5V
Jumper 2 Position		Description
Pin 2-4	Pin 4-6	
X	-	Panel Power = +3,3V
-	X	Panel Power = +5V

"X" = Jumper set (short) and "-" = jumper not set (open)

7.15.2. AT _ATX Mode / MPCIE1 mSATA / mPCIE Selection (JP2)

Figure 27: AT _ATX Mode / MPCIE1 mSATA / mPCIE Selection JP2

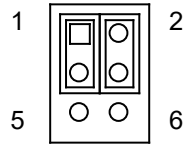

Table 41: Pin Assignment JP2

Jumper 1 Position		Description
Pin 1-3	Pin 3-5	
X	-	ATX Mode (Default)
-	X	AT Mode
Jumper 2 Position		Description
Pin 2-4	Pin 4-6	
X	-	MPCIE1 mSATA Selected (Default)
-	X	MPCIE1 mPCIE Selected

"X" = Jumper set (short) and "-" = jumper not set (open)

7.15.3. Backlight Power Enable Selection for LVDS1 (JP3)

Figure 28: Backlight Power Enable Selection JP3

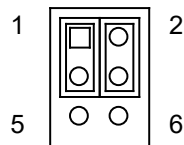

Table 42: Pin Assignment JP3

Jumper 1 Position		Description
Pin 1-3	Pin 3-5	
X	-	Backlight Enable Voltage = +3.3V
-	X	Backlight Enable Voltage = +5V
Jumper 2 Position		Description
Pin 2-4	Pin 4-6	
X	-	Active High
-	X	Active Low

"X" = Jumper set (short) and "-" = jumper not set (open)

7.15.4. MPCIE Activity LED Indication (JP4)

Figure 29: MPCIE Activity LED Indication JP4

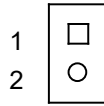

Table 43: Pin Assignment JP4

Pin	Signal	Note
1	LED+	
2	LED-	

7.15.5. USB Power Selection (JP5)

Figure 30: USB Power Selection JP5

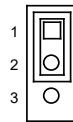

Table 44: Pin Assignment JP5

Jumper Position		Description
Pin 1-2	Pin 2-3	
X	-	USB power will be cut off in S4 & S5 state.
-	X	USB power will be cut off in Deep S5 state.

"X" = Jumper set (short) and "-" = jumper not set (open)

7.15.6. Flash Description Security Over-ride (JP6)

Figure 31: Flash Description Security Over-ride JP6

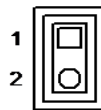

Table 45: Pin Assignment JP6

Jumper Position		Description
Pin 1-2		
X		Enabled
-		Disabled

"X" = Jumper set (short) and "-" = jumper not set (open)

7.15.7. RTC Reset Selection (JP7)

The "RTC Reset" jumper (JP7) can be used to reset the Real Time Clock (RTC) and drain RTC well.

The jumper has one position: Pin 1-2 and not mounted (default position). More information on setting the "RTC Reset" jumper can be found in the following table.

Figure 32: RTC Reset Selection JP7

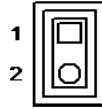

Table 46: Pin Assignment JP7

Jumper Position	Description
Pin 1-2	
X	Enable Clear CMOS RTC content (board does not boot with the jumper in this position)
-	Normal operation (default position)

"X" = Jumper set (short) and "-" = jumper not set (open)



Do not leave the jumper in position 1-2, otherwise if the power is disconnected, the battery will fully deplete within a few weeks.

7.15.8. SRTC Reset Selection (JP8)

Figure 33: SRTC Reset Selection JP8

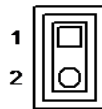

Table 47: Pin Assignment JP8

Jumper Position	Description
Pin 1-2	
X	Clear ME Registers
-	Normal Operation

"X" = Jumper set (short) and "-" = jumper not set (open)

8/ On-Board Connectors & Mating Connector Types

The Mating connectors / Cables are connectors or cable kits which are fitting the On-board connector.

The cable kits marked with "*" are included in the "ECX-HSW-U Cable & Driver Kit".

Table 48: On-Board Connectors & Mating Connector Types

Connector	On-Board Connectors		Mating Connectors / Cables	
	Manufact.	Type No.	Manufact.	Type No.
Battery Input (BAT1)	Pinrex	712-73-02TWR0		
DC 12V Power Input (CN4)	Pinrex	733-97-04TBR1		0C5020000001580L
HDD Power Output (CN1)	YIMTEX	512CW45T-2R		0C5020000002370L
USB 2.0 (CN5)	YIMTEX	3362*05SANGR-09		0C502USB0201010L
Audio AMP (CN7, CN8)	YIMTEX	503PW1*02STR		
Audio Input / Output (CN9)	Pinrex	212-92-06GB01		0C5020000002050L
DIO (CN10)	Pinrex	712-73-10TWB0		0C5020000002060L
COM (CN15, CN16)	Pinrex	712-73-10TWB0		0C5020000000910L
SIM (CN17)	Pinrex	712-73-06TWB0		0ZHK12003GSIM003
Backlight Power (CN18)	YIMTEX	501MW1X07MTR-1R		
SO-DIMM (DIMM1)	LINKTEK	DDRRK-20401-TP7B		
FAN (FAN1)	YIMTEX	521AW1*03STR		
Front Panel (FP1)	YIMTEX	3362*04SANGR		
Front Panel (FP2)	YIMTEX	3362*05SANGR		
LVDS Panel (LVDS1)	JAE	FI-X305SL-HF		
mPCIe (MPCIE1)	FOXCONN	A50B226-S56Q-7H		
mPCIe (MPCIE2)	FOXCONN	A50B226-S99Q-7H		
SATA (SATA1, SATA2)	FOXCONN	LD1807V-S52U		0C5020000004240L



Please note that standard connectors like DP, mPCIe, Audio Jack, Ethernet and USB are not included in the list.

9/ BIOS

9.1. Starting the uEFI BIOS

The ECX-HSW-U is provided with a Kontron-customized, pre-installed and configured version of AMI Aptio® V uEFI BIOS. AMI BIOS firmware is based on the Unified Extensible Firmware Interface (UEFI) specification and the Intel® Platform Innovation Framework for EFI. This uEFI BIOS provides a variety of new and enhanced functions specifically tailored to the hardware features of the ECX-HSW-U.

The uEFI BIOS comes with a setup program that provides quick and easy access to the individual function settings for control or modification of the uEFI BIOS configuration. The setup program allows the accessing of various menus that provide functions or access to sub-menus with more specific functions of their own.

To start the uEFI BIOS setup program, follow the steps below:

1. Power on the board.
2. Wait until the first characters appear on the screen (POST messages or splash screen).
3. Press the key.
4. If the uEFI BIOS is password-protected, a request for password will appear. Enter either the User Password or the Supervisor Password (see Security menu), press <RETURN>, and proceed with step 5.
5. A setup menu will appear.

The ECX-HSW-U uEFI BIOS setup program uses a hot key-based navigation system. A hot key legend bar is located on the bottom of the setup screens.

The following table provides information concerning the usage of these hot keys.

Table 49: Font Size Table

Hotkeys	Description
<F1>	The <F1> key invokes the General Help window.
<->	The <Minus> key selects the next lower value within a field.
<+>	The <Plus> key selects the next higher value within a field.
<F2>	The <F2> key loads the previous values.
<F3>	The <F3> key loads the standard default values.
<F4>	The <F4> key saves the current settings and exit the uEFI BIOS setup.
<→> or <←>	The <Left/Right> arrows selects major setup menus on the menu bar. For example: Main, Advanced, Security, etc.
<↑> or <↓>	The <Up/Down> arrows selects fields in the current menu. For example: A setup function or a sub-screen.
<ESC>	The <ESC> key exits a major setup menu and enter the Exit setup menu. Pressing the <ESC> key in a sub-menu displays the next higher menu level.
<RERURN>	The <RETURN> key executes a command or select a submenu.

9.2. Setup Menus

The Setup utility features shows six menus in the selection bar at the top of the screen:

- ▶ Main
- ▶ Advanced
- ▶ Power
- ▶ Boot
- ▶ Security
- ▶ Save & Exit

The Setup menus are selected via the left and right arrow keys. The currently active menu and the currently active uEFI BIOS Setup item are highlighted in white. Each Setup menu provides two main frames. The left frame displays all available functions. Functions that can be configured are displayed in blue. Functions displayed in gray provide information about the status or the operational configuration. The right frame displays an Item Specific Help window providing an explanation of the respective function.

9.2.1. Main Setup Menu

Upon entering the uEFI BIOS Setup program, the Main Setup menu is displayed. This screen lists the Main Setup menu sub-screens and provides basic system information. Additionally functions for setting the system time and date are offered.

Table 50: Main Setup Menu Sub-Screens and Functions

Function	Description
BIOS Information	Read only field. Displays information about the system BIOS
Memory Information	Read only field. Displays information about total memory
ME Information	Read only field. Displays information about Intel Management Engine (ME) version
TXE Information	Read only field. Displays information about TXE information
Firmware Information	Code version and firmware information
System Date	Set System Date
System Time	Set System Time

Figure 34: BIOS Main Menu Screen System Data and Time

BIOS SETUP UTILITY					
Main	Advanced	Power	Boot	Security	Save & Exit
Product Information					
Product Name		ECX-HSW-U-4010U			
BIOS Version		Z0.05 (x64)			
BIOS Build Date		01/28/2015			
ME FW Version		N/A			
CPU Information					
Intel® Core™ i3-4010U @ 1.70GHz					
Microcode Revision		1c			
Processor Cores		2		→ ←: Select Screen	
Memory Information					
Total Size		4096 MB (DDR3)		↑ ↓: Select Item	
Frequency		1600 MHz		Enter: Select	
System Date		[Fri 02/14/2014]		+/-: Change Opt.	
System Time		[13:23:12]		F1: General Help	
Access Level		Administrator		F2: Previous Values	
				F3: Optimized Defaults	
				F4: Save & Exit	
				ESC: Exit	
Version 2.17.1246. Copyright (C) 2015, American Megatrends, Inc.					

Feature	Option	Description
System Date	[dd/mm/yyyy]	Set the Date. Use Tab to switch between Data elements.
System Time	[hh:mm:ss]	Set the Time. Use Tab to switch between Time elements.

9.2.2. Advanced Setup Menu

The Advanced setup menu provides sub-screens and functions for advanced configurations. The following sub-screen functions are included in the menu:

- ▶ LAN & Audio Configuration
- ▶ Display Configuration
- ▶ Super IO Configuration
- ▶ CPU Chipset Configuration
- ▶ SATA Configuration
- ▶ USB Configuration
- ▶ Intel® Rapid Start Technology
- ▶ DIO Configuration
- ▶ H/W Monitor

NOTICE

Setting items on this screen to incorrect values may cause the system to malfunction.

Figure 35: BIOS Advanced Menu

BIOS SETUP UTILITY					
Main	Advanced	Power	Boot	Security	Save & Exit
Onboard LAN1 Controller		[Enabled]			
Onboard LAN1 Boot		[Disabled]			
Onboard LAN2 Controller		[Enabled]			
Onboard LAN2 Boot		[Disabled]			
Onboard LAN3 Controller		[Enabled]			
Onboard LAN3 Boot		[Disabled]			
Audio Controller		[Enabled]			
> Display Configuration					
> Super IO Configuration					
> CPU Chipset Configuration					
> SATA Configuration					
> USB Configuration					
> DIO Configuration					
> H/W Monitor					
				→ ←: Select Screen	
				↑ ↓: Select Item	
				Enter: Select	
				+/-: Change Opt.	
				F1: General Help	
				F2: Previous Values	
				F3: Optimized Defaults	
				F4: Save & Exit	
				ESC: Exit	
Version 2.17.1246. Copyright (C) 2015, American Megatrends, Inc.					

Feature	Option	Description
Onboard LAN1/2/3 Controller	[Disabled], [Enabled]	Select whether to enable or disable Onboard LAN1/2/3 Controller.
Onboard LAN1/2/3 Boot	[Disabled], [Enabled]	Select whether to enable or disable load onboard PXE (Preboot Execution Environment).
Audio Controller	[Disabled], [Enabled]	Select whether to enable or disable Audio Controller.

Figure 36: BIOS Advanced Menu - Display Configuration

BIOS SETUP UTILITY					
Main	Advanced	Power	Boot	Security	Save & Exit
Display Configuration					
UWA Frame Buffer Size		[256MB]	→ ←: Select Screen		
DVMT Pre-Allocated		[64M]	↑ ↓: Select Item		
DVMT Total Gfx Mem		[256M]	Enter: Select		
Primary IGFX Boot Display		[VBIOS Default]	+/-: Change Opt.		
Active LVDS		[Disabled]	F1: General Help		
			F2: Previous Values		
			F3: Optimized Defaults		
			F4: Save & Exit		
			ESC: Exit		
Version 2.17.1246. Copyright (C) 2015, American Megatrends, Inc.					

Feature	Option	Description
UWA Frame Buffer Size	[128MB], [256MB], [512MB]	Select the Aperture Size.
DVMT Pre-Allocated	[32M], [64M], [96M], [128M], [160M], [192M], [224M], [256M], [288M], [320M], [352M], [384M], [416M], [448M], [480M], [512M], [1024M]	Select DVMT Pre-Allocated (Fixed) Graphics Memory size used by the Internal Graphics Device.
DVMT Total Gfx Mem	[128M], [256M], [MAX]	Select DVMT Total Graphic Memory size used by the Internal Graphics Device.
Primary IGFC Boot Display	[VBIOS Default], [DP1], {DP2}, [LVDS]	Select the Video Device which will be activated during POST. This has no effect if external graphics present. Secondary boot display selection will appear based on your selection. DOS modes will be supported only on primary display.
Active LVDS	[Disabled], [Enabled]	Select the Active LVDS Configuration. [Disabled]: VBIOS does not enable LVDS. [Enabled]: VBIOS will enable LVDS.

Figure 37: BIOS Advanced Menu - Super IO Configuration

BIOS SETUP UTILITY					
Main	Advanced	Power	Boot	Security	Save & Exit
Super IO Configuration					
> Serial Port 1 Configuration > Serial Port 2 Configuration				→ ←: Select Screen ↑ ↓: Select Item Enter: Select +/-: Change Opt. F1: General Help F2: Previous Values F3: Optimized Defaults F4: Save & Exit ESC: Exit	
Version 2.17.1246. Copyright (C) 2015, American Megatrends, Inc.					

Figure 38: BIOS Advanced Menu - Super IO Configuration - Serial Port 1 Configuration

BIOS SETUP UTILITY					
Main	Advanced	Power	Boot	Security	Save & Exit
Serial Port 1 Configuration					
Serial Port		[Enabled]		→ ←: Select Screen ↑ ↓: Select Item Enter: Select +/-: Change Opt. F1: General Help F2: Previous Values F3: Optimized Defaults F4: Save & Exit ESC: Exit	
Device Settings		IO=3F8h; IRQ=4;			
Change Setting		[Auto]			
Serial Port 1 Type		[RS232]			
RS485 Deplx Mode*		[Half Duplex]			
RS485 Auto Flow Control		[Disabled]			
Version 2.17.1246. Copyright (C) 2015, American Megatrends, Inc.					

* These items appear only when selecting RS485 for the Serial Port 1 Type.

Feature	Option	Description
Serial Port	[Disabled], [Enabled]	Select whether to enable or disable Serial Port (COM).
Change Settings	[Auto], [IO=3F8h; IRQ=4;], [IO=3F8h; IRQ=3, 4, 5, 6, 7, 9, 10, 11, 12;], [IO=2F8h; IRQ=3, 4, 5, 6, 7, 9, 10, 11, 12;], [IO=3E8h; IRQ=3, 4, 5, 6, 7, 9, 10, 11, 12;], [IO=2E8h; IRQ=3, 4, 5, 6, 7, 9, 10, 11, 12;]	Select an optional setting for Super IO device.

Feature	Option	Description
Serial Port 1 Type	[RS232], [RS422], [RS485]	Select an appropriate type for Serial Port 1.
RS485 Duplex Mode	[Half Duplex], [Full Duplex]	Select an appropriate RS485 Duplex Mode.
RS485 Auto Flow Control	[Disabled], [Enabled]	Select whether to enable or disable RS485 Auto Flow Control.

Figure 39: BIOS Advanced Menu - Super IO Configuration - Serial Port 2 Configuration

BIOS SETUP UTILITY					
Main	Advanced	Power	Boot	Security	Save & Exit
Serial Port 2 Configuration					
Serial Port		[Enabled]		→ ←: Select Screen	
Device Settings		IO=2F8h; IRQ=3;		↑ ↓: Select Item	
Change Setting		[Auto]		Enter: Select	
Serial Port 2 Type		[RS232]		+/-: Change Opt.	
RS485 Deplx Mode*		[Half Duplex]		F1: General Help	
RS485 Auto Flow Control		[Disabled]		F2: Previous Values	
				F3: Optimized Defaults	
				F4: Save & Exit	
				ESC: Exit	
Version 2.17.1246. Copyright (C) 2015, American Megatrends, Inc.					

* These items appear only when selecting RS485 for the Serial Port 2 Type.

Feature	Option	Description
Serial Port	[Disabled], [Enabled]	Select whether to enable or disable Serial Port (COM).
Change Settings	[Auto], [IO=2F8h; IRQ=3;], [IO=3F8h; IRQ=3, 4, 5, 6, 7, 9, 10, 11, 12;], [IO=2F8h; IRQ=3, 4, 5, 6, 7, 9, 10, 11, 12;], [IO=3E8h; IRQ=3, 4, 5, 6, 7, 9, 10, 11, 12;], [IO=2E8h; IRQ=3, 4, 5, 6, 7, 9, 10, 11, 12;]	Select an optional setting for Super IO device.
Serial Port 2 Type	[RS232], [RS422], [RS485]	Select an appropriate type for Serial Port 2.
RS485 Duplex Mode	[Half Duplex], [Full Duplex]	Select an appropriate RS485 Duplex Mode.
RS485 Auto Flow Control	[Disabled], [Enabled]	Select whether to enable or disable RS485 Auto Flow Control.

Figure 40: BIOS Advanced Menu - CPU Chipset Configuration

BIOS SETUP UTILITY					
Main	Advanced	Power	Boot	Security	Save & Exit
CPU Chipset Configuration					
EIST		[Enabled]			
Hyper-threading		[Enabled]			
VT-d		[Enabled]			
Active Processor Cores		[All]			
Limit CPUID Maximum		[Disabled]			
Execute Disable Bit		[Enabled]			
Intel Virtualization Technology		[Disabled]			
Package Power Limit		[Enabled]			
Cpu Power Limit1		0			
Cpu Power Limit1 Time		0			→ ←: Select Screen
Cpu Power Limit2		20			↑ ↓: Select Item
Platform Power limit lock		[Enabled]			Enter: Select
Cpu Power Limit3		0			+/-: Change Opt.
Cpu Power Limit3 Time		0			F1: General Help
Cpu Power Limit Duty Cycle		0			F2: Previous Values
DDR Power Limit 1		0			F3: Optimized Defaults
DDR Power Limit1 Time		0			F4: Save & Exit
DDR Power Limit2		0			ESC: Exit
Version 2.17.1246. Copyright (C) 2015, American Megatrends, Inc.					

Feature	Option	Description
EIST	[Disabled], [Enabled]	Select whether to enable or disable Enhanced Intel SpeedStep Technology.
Hyper-threading	[Disabled], [Enabled]	Select whether to enable or disable Hyper-threading technology. [Enabled] for Windows XP and Linux (OS optimized for Hyper-Threading Technology). [Disabled] for other OS (OS not optimized for Hyper-Threading Technology).
VT-d	[Disabled], [Enabled]	Select whether to enable or disable VT-d capability.
Active Processor Cores	[All], [1]	Select the number of cores to enable in each processor package.
Limit CPUID Maximum	[Disabled], [Enabled]	Select whether to limit CPUID maximum value.
Execute Disable Bit	[Disabled], [Enabled]	Select whether to enable or disable Execute Disable Bit functionality, which prevents malicious buffer overflow attacks..
Intel Virtualization Technology	[Disabled], [Enabled]	Select whether to enable or disable Intel Virtualization Technology.
Package Power Limit	[Disabled], [Enabled]	Select whether to lock the power limit of the entire processor. A system reset is required to unlock the register when enabling this feature.

Feature	Option	Description
Platform Power Limit Lock	{Disabled}, [Enabled]	Select whether to lock the power limit of the motherboard. A system reset is required to unlock the register when enabling this feature.

Figure 41: BIOS Advanced Menu - SATA Configuration

BIOS SETUP UTILITY					
Main	Advanced	Power	Boot	Security	Save & Exit
SATA Configuration					
SATA Controller(s)		[Enabled]		→ ←: Select Screen ↑ ↓: Select Item Enter: Select +/-: Change Opt. F1: General Help F2: Previous Values F3: Optimized Defaults F4: Save & Exit ESC: Exit	
SATA Mode Selection		[AHCI]			
SATA Controller Speed		[Default]			
Serial ATA Port 1		Empty			
Port 1		[Enabled]			
Serial ATA Port 2		Empty			
Port 2		[Enabled]			
mS ATA Port 1		Sandisk SSD U1 (32.0GB0			
Port 1		[Enabled]			
Version 2.17.1246. Copyright (C) 2015, American Megatrends, Inc.					

Feature	Option	Description
SATA Controller(s)	[Enabled], [Disabled]	Select whether to enable or disable SATA Controller(s).
SATA Mode Selection	[AHCI]	Determine how SATA controller(s) operate.
SATA Controller Speed	[Default], [Gen1], [Gen2], [Gen3]	Determine the maximum speed that the SATA controller can support.
Port 1/2	[Disabled], [Enabled]	Select whether to enable or disable SATA Port 1, 2 or mSATA Port 1.

Figure 42: BIOS Advanced Menu - USB Configuration

BIOS SETUP UTILITY					
Main	Advanced	Power	Boot	Security	Save & Exit
USB Configuration					
USB Devices: 1 Keyboard, 1 Mouse, 1 Hubs				→ ←: Select Screen ↑ ↓: Select Item Enter: Select +/-: Change Opt. F1: General Help F2: Previous Values F3: Optimized Defaults F4: Save & Exit ESC: Exit	
Legacy USB Support		[Enabled]			
xHCI Legacy Support		[Enabled]			
xHCI Hand-off		[Enabled]			
EHCI Hand-off		[Disabled]			
USB Mass Storage Driver Support		[Enabled]			
Version 2.17.1246. Copyright (C) 2015, American Megatrends, Inc.					

Feature	Option	Description
Legacy USB Support	[Enabled], [Disabled], [Auto]	Select whether to enable or disable Legacy USB support. AUTO option disables legacy support if no USB devices are connected.
XHCI Legacy Support	[Disabled], [Enabled]	Select whether to enable or disable XHCI controller legacy support.
XHCI Hand-off	[Enabled], [Disabled]	Select whether to enable or disable XHCI Hand-off function. This is a workaround for OSes without XHCI hand-off support. The XHCI ownership change should be claimed by XHCI driver.
EHCI Hand-off	[Disabled], [Enabled]	Select whether to enable or disable EHCI Hand-off function. This is a workaround for OSes without EHCI hand-off support. The EHCI ownership change should be claimed by EHCI driver.
USB Mass Storage Driver Support	[Disabled], [Enabled]	Select whether to enable or disable USB Mass Storage Driver Support.

Figure 43: BIOS Advanced Menu - Intel® Rapid Start Technology

BIOS SETUP UTILITY					
Main	Advanced	Power	Boot	Security	Save & Exit
Intel® Rapid Start Technology		[Disabled]			
				→ ←: Select Screen ↑ ↓: Select Item Enter: Select +/-: Change Opt. F1: General Help F2: Previous Values F3: Optimized Defaults F4: Save & Exit ESC: Exit	
Version 2.17.1246. Copyright (C) 2015, American Megatrends, Inc.					

Feature	Option	Description
Intel® Rapid Start Technology	[Disabled], [Enabled]	Select whether to enable or disable Intel® Rapid Start Technology.

Figure 44: BIOS Advanced Menu - DIO Configuration

BIOS SETUP UTILITY					
Main	Advanced	Power	Boot	Security	Save & Exit
DIO Configuration					
User Configuration		[Disabled]			
DO_1*		[Output Low]			
DO_2*		[Output Low]			
DO_3*		[Output Low]			
DO_4*		[Output Low]			
DI_1				→ ←: Select Screen	
DI_2				↑ ↓: Select Item	
DI_3				Enter: Select	
DI_4				+/-: Change Opt.	
DO_1				F1: General Help	
DO_2				F2: Previous Values	
DO_3				F3: Optimized Defaults	
DO_4				F4: Save & Exit	
				ESC: Exit	
Version 2.17.1246. Copyright (C) 2015, American Megatrends, Inc.					

* These items appear only when enabling User Configuration.

Feature	Option	Description
User Configuration	[Enabled], [Disabled]	Select whether or not to allow user to set the DO pin output value.
DO_1..4	[Output Low], [Output High]	Set up the DIO pin output value.

Figure 45: BIOS Advanced Menu - H/W Monitor

BIOS SETUP UTILITY					
Main	Advanced	Power	Boot	Security	Save & Exit
PC Health Status					
> Smart FAN Configuration					
CPU Temperature		: +80 C		→ ←: Select Screen ↑ ↓: Select Item Enter: Select +/-: Change Opt. F1: General Help F2: Previous Values F3: Optimized Defaults F4: Save & Exit ESC: Exit	
Memory Temperature		: +64 C			
System Temperature		: +54 C			
CPU Fan Speed		: N/A			
+V CORE		: +1.711 V			
+VIN		: +12.000 V			
+5V		: +5.114 V			
+3.3V		: +3.372 V			
Version 2.17.1246. Copyright (C) 2015, American Megatrends, Inc.					

BIOS SETUP UTILITY					
Main	Advanced	Power	Boot	Security	Save & Exit
Smart FAN Configuration					
CPU FAN Setting		[Manual]		→ ←: Select Screen ↑ ↓: Select Item Enter: Select +/-: Change Opt. F1: General Help F2: Previous Values F3: Optimized Defaults F4: Save & Exit ESC: Exit	
Manual Duty		255			
Version 2.17.1246. Copyright (C) 2015, American Megatrends, Inc.					

Feature	Option	Description
CPU FAN Setting	[Manual], [Smart]	Switch the CPU FAN control mode.

9.2.3. Power Setup Menu

The Power setup menu provides functions and a sub-screen for power configurations. The following sub-screen function is included in the menu:

- ▶ WatchDog Timer Configuration

Figure 46: BIOS Power Setup Menu

BIOS SETUP UTILITY					
Main	Advanced	Power	Boot	Security	Save & Exit
Power Configuration					
ACPI Sleep State		[S3 only (Suspend to RAM)]			
Restore AC Power Loss		[Power Off]			
Power Saving Mode		[Disabled]			
Resume Event Control					
Resume By PCIE Device		[Disabled]			
Resume By RTC Alarm		[Disabled]			
> WatchDog Timer Configuration					
				→ ←: Select Screen	
				↑ ↓: Select Item	
				Enter: Select	
				+/-: Change Opt.	
				F1: General Help	
				F2: Previous Values	
				F3: Optimized Defaults	
				F4: Save & Exit	
				ESC: Exit	
Version 2.17.1246. Copyright (C) 2015, American Megatrends, Inc.					

Feature	Option	Description
ACPI Sleep State	[Suspend Disabled], [S3 only (Suspend to RAM)]	Select whether to enable or disable suspend function and determine an appropriate suspend mode.
Restore AC Power Loss	[Power Off], [Power On], [Last State]	Control whether the system will stay on after AC power is removed and then restored. Select [Power Off] if you want the system to remain off after power restored. Select [Power On] if you use a power strip to turn the system on.
Power Saving Mode	[Disabled], [EUP Enabled], [DeepSx Enabled]	Select whether to enable Power Saving Mode.
Resume By PCIE Device	[Disabled], [Enabled]	Select whether to enable or disable Wake from PCIE Device.
Resume By RTC Alarm	[Disabled], [Enabled]	Select whether to enable or disable Wake Up on Alarm, to turn on your system on a special day of the month.

Figure 47: BIOS Power Setup Menu - WatchDog Timer Configuration

BIOS SETUP UTILITY					
Main	Advanced	Power	Boot	Security	Save & Exit
WatchDog Timer Configuration					
WDT Function		[Disabled]		→ ←: Select Screen ↑ ↓: Select Item Enter: Select +/-: Change Opt. F1: General Help F2: Previous Values F3: Optimized Defaults F4: Save & Exit ESC: Exit	
Version 2.17.1246. Copyright (C) 2015, American Megatrends, Inc.					

Feature	Option	Description
WDT Function	[Disabled], [Enabled]	Select whether to enable or disable WatchDog Timer function.

9.2.4. Boot Setup Menu

The boot setup menu lists the for boot device priority order, that is generated dynamically.

Figure 48: BIOS Boot Setup Menu

BIOS SETUP UTILITY					
Main	Advanced	Power	Boot	Security	Save & Exit
Boot Configuration					
Full Screen LOGO Display		[Disabled]			
Setup Prompt Timeout		1		→ ←: Select Screen	
Bootup NumLock State		[On]		↑ ↓: Select Item	
CSM Support		[Enabled]		Enter: Select	
Boot Option Filter		[Legacy Only]		+/-: Change Opt.	
Boot Option Priorities				F1: General Help	
				F2: Previous Values	
				F3: Optimized Defaults	
				F4: Save & Exit	
				ESC: Exit	
Version 2.17.1246. Copyright (C) 2015, American Megatrends, Inc.					

Feature	Option	Description
Full Screen LOGO Display	[Disabled], [Enabled]	Select whether to enable or disable to display logo screen.
Bootup NumLock State	[On], [Off]	Select the state of the NumLock feature of the keyboard after Startup. [On]: The keys on the keypad will act as numeric keys. [Off]: The keys on the keypad will act as cursor keys.
CSM Support	[Enabled], [Disabled]	Select whether to enable or disable CSM support.
Boot Option Filter	[UEFI and Legacy], [Legacy only], [UEFI only]	Control Legacy / UEFI ROMs priority.

9.2.5. Security Setup Menu

The Security setup menu provides information about the passwords and functions for specifying the security settings. The passwords are case-sensitive. The ECX-HSW-U provides no factory-set passwords.

NOTICE

If there is already a password installed, the system asks for this first. To clear a password, simply enter nothing and acknowledge by pressing <RETURN>. To set a password, enter it twice and acknowledge by pressing <RETURN>.

Figure 49: BIOS Boot Setup Menu

BIOS SETUP UTILITY					
Main	Advanced	Power	Boot	Security	Save & Exit
Password Description					
If ONLY the Administrator's password is set, then this only limits access to Setup and is only asked for when entering Setup					
If ONLY the User's password is set, then this is a power on password and must be entered to boot or enter Setup. In Setup the User will have Administrator rights					
The password length must be in the following range:				→ ←: Select Screen	
Minimum Length		3		↑ ↓: Select Item	
Maximum length		20		Enter: Select	
Administrator Password				+/-: Change Opt.	
User Password				F1: General Help	
Secure Boot menu				F2: Previous Values	
				F3: Optimized Defaults	
				F4: Save & Exit	
				ESC: Exit	
Version 2.17.1246. Copyright (C) 2015, American Megatrends, Inc.					

Feature	Description
Administrator Password	Set administrator password
User Password	Set user password



If only the administrator's password is set, then only access to setup is limited. The password is only entered when entering setup.

If only the user's password is set, then the password is a power on password and must be entered to boot or enter setup. Within the setup menu the user has administrator rights.

Password length requirements are maximum 20 characters and minimum 3 characters.

9.2.5.1. Remember the password

It is highly recommended to keep a record of all passwords in a safe place. Forgotten passwords results in being locked out of the system.

If the system cannot be booted because the User Password or the Supervisor Password are not know, contact Kontron Support for further assistance.



HDD security passwords cannot be cleared using the above method.

9.2.6. Save & Exit Setup Menu

The exit setup menu provides functions for handling changes made to the UEFI BIOS settings and the exiting of the setup program.

Figure 50: BIOS Boot Setup Menu

BIOS SETUP UTILITY					
Main	Advanced	Power	Boot	Security	Save & Exit
Save Changes and Reset					
Discard Changes and Reset					
Save Options				→ ←: Select Screen	
Save Changes				↑ ↓: Select Item	
Discard Changes				Enter: Select	
Restore Defaults				+/-: Change Opt.	
				F1: General Help	
				F2: Previous Values	
				F3: Optimized Defaults	
				F4: Save & Exit	
				ESC: Exit	
Version 2.17.1246. Copyright (C) 2015, American Megatrends, Inc.					

Feature	Description
Save Changes and Exit	Exit system setup after saving the changes. Once you are finished making your selections, choose this option from the Exit menu to ensure the values you selected are saved to the CMOS RAM. The CMOS RAM is sustained by an onboard backup battery and stays on even when the PC is turned off. When you select this option, a confirmation window appears. Select [Yes] to save changes and exit.
Discard Changes and Exit	Exit system setup without saving any changes. Select this option only if you do not want to save the changes that you made to the Setup program. If you made changes to fields other than system date, system time, and password, the BIOS asks for a confirmation before exiting.
Save Changes	Save changes done so far to any of the setup values. This option allows you to save the selections you made. After selecting this option, a confirmation appears. Select [Yes] to save any changes.
Discard Changes	Discards changes done so far to any of the setup values. This option allows you to discard the selections you made and restore the previously saved values. After selecting this option, a confirmation appears. Select [Yes] to discard any changes and load the previously saved values.
Restore Defaults	Restore Default values for all the setup values. This option allows you to load optimal default values for each of the parameters on the Setup menus, which will provide the best performance settings for your system. The F9 key can be used for this operation.

Appendix A: List of Acronyms



The following table does not contain the complete acronyms used in signal names, signal type definitions or similar. A description of the signals is included in the I/O Connector and Internal connector chapters within this user guide.

Table 51: List of Acronyms

2D	Two-Dimensional
3D	Three-Dimensional
AHCI	Advanced Host Controller Interface
AMT	Active Management Technology
AT	Advanced Technology
ATX	Advanced Technology eXtended
BGA	Ball Grid Array
BIOS	Basic Input / Output System
BSP	Board Support Package
CMOS	Complementary Metal Oxide Semiconductor
CPU	Central Processing Unit
DC	Direct Current
DDC	Display Data Channel
DIO	Digital Input / Output
DP	DisplayPort
ECC	Error-Correcting Code
ECX	Embedded Compact eXtended
EEE	Electrical and Electronic Equipment
EIST	Enhanced Intel SpeedStep Technology
EOS	Electrical OverStress
ESD	ElectroStatic Discharge
GbE	Gigabit Ethernet
HDD	Hard Disk Drive
HDMI	High Definition Multimedia Interface
LAN	Local Area Network
LED	Light Emitting Device
LVDS	Low-Voltage Differential Signaling
ME F/W	Management Engine Firmware
mPCIe	mini Peripheral Component Interconnect express
NGFF	Next Generation Form Factor
PC-AT	Personal Computer - Advanced Technology
PCB	Printed Circuit Board
PSU	Power Supply Unit
PVC	PolyViny Chloride
PWM	Pulse Width Modulation
RAM	Random Access Memory
ROM	Read-Only Memory
RTC	Real-Time Clock
SATA	Serial Advanced Technology Attachment
SD	Secure Digital memory card
SDP	Serial Download Protocol
SELV	Safety Extra-Low Voltage
SIM	Subscriber Identity Module
SMBus	System Management Bus
SoC	System on Chip
SO-DIMM	Small Outline Dual In-line Memory Module
SPD	Serial Presence Detect
SPI	Serial Peripheral Interface
TDP	Thermal Design Power
TPM	Trusted Platform Module
UEFI	Unified Extensible Firmware Interface
USB	Universal Serial Bus
UTP	Update Transfer Protocol
VGA	Video Graphics Array
WDT	WatchDog Timer
WEEE	Waste Electrical and Electronic Equipment



About Kontron

Kontron is a global leader in embedded computing technology (ECT). As a part of technology group S&T, Kontron offers a combined portfolio of secure hardware, middleware and services for Internet of Things (IoT) and Industry 4.0 applications. With its standard products and tailor-made solutions based on highly reliable state-of-the-art embedded technologies, Kontron provides secure and innovative applications for a variety of industries. As a result, customers benefit from accelerated time-to-market, reduced total cost of ownership, product longevity and the best fully integrated applications overall. Kontron is a listed company. Its shares are traded in the Prime Standard segment of the Frankfurt Stock Exchange and on other exchanges under the symbol "KBC". For more information, please visit: www.kontron.com

▼

PRODUCT CONTACT
POINT

KONTRON ASIA INC.

4F, No. 415, Ti-Ding Blvd.,
Sec. 2, Neihu District,
Taipei, Taiwan 11493
Tel.: + 886 2 2799 2789
Fax: + 886 2 2799 7399
SalesAsia@kontron.com