

3.5"-SBC-SKL

Doc. User Guide, Rev. 2.4

Doc. ID: [To be Determined]

This page has been intentionally left blank

 3.5"-SBC-SKL - USER GUIDE

Disclaimer

Kontron would like to point out that the information contained in this user guide may be subject to alteration, particularly as a result of the constant upgrading of Kontron products. This document does not entail any guarantee on the part of Kontron with respect to technical processes described in the user guide or any product characteristics set out in the user guide. Kontron assumes no responsibility or liability for the use of the described product(s), conveys no license or title under any patent, copyright or mask work rights to these products and makes no representations or warranties that these products are free from patent, copyright or mask work right infringement unless otherwise specified. Applications that are described in this user guide are for illustration purposes only. Kontron makes no representation or warranty that such application will be suitable for the specified use without further testing or modification. Kontron expressly informs the user that this user guide only contains a general description of processes and instructions which may not be applicable in every individual case. In cases of doubt, please contact Kontron.

This user guide is protected by copyright. All rights are reserved by Kontron. No part of this document may be reproduced, transmitted, transcribed, stored in a retrieval system, or translated into any language or computer language, in any form or by any means (electronic, mechanical, photocopying, recording, or otherwise), without the express written permission of Kontron. Kontron points out that the information contained in this user guide is constantly being updated in line with the technical alterations and improvements made by Kontron to the products and thus this user guide only reflects the technical status of the products by Kontron at the time of publishing.

Brand and product names are trademarks or registered trademarks of their respective owners.

©2022 by Kontron Europe GmbH

Kontron Europe GmbH

Gutenbergstraße 2
85737 Ismaning
Germany
www.kontron.com

High Risk Applications Hazard Notice

THIS DEVICE AND ASSOCIATED SOFTWARE ARE NOT DESIGNED, MANUFACTURED OR INTENDED FOR USE OR RESALE FOR THE OPERATION OF NUCLEAR FACILITIES, THE NAVIGATION, CONTROL OR COMMUNICATION SYSTEMS FOR AIRCRAFT OR OTHER TRANSPORTATION, AIR TRAFFIC CONTROL, LIFE SUPPORT OR LIFE SUSTAINING APPLICATIONS, WEAPONS SYSTEMS, OR ANY OTHER APPLICATION IN A HAZARDOUS ENVIRONMENT, OR REQUIRING FAIL-SAFE PERFORMANCE, OR IN WHICH THE FAILURE OF PRODUCTS COULD LEAD DIRECTLY TO DEATH, PERSONAL INJURY, OR SEVERE PHYSICAL OR ENVIRONMENTAL DAMAGE (COLLECTIVELY, "HIGH RISK APPLICATIONS").

You understand and agree that your use of Kontron devices as a component in High Risk Applications is entirely at your risk. To minimize the risks associated with your products and applications, you should provide adequate design and operating safeguards. You are solely responsible for compliance with all legal, regulatory, safety, and security related requirements concerning your products. You are responsible to ensure that your systems (and any Kontron hardware or software components incorporated in your systems) meet all applicable requirements. Unless otherwise stated in the product documentation, the Kontron device is not provided with error-tolerance capabilities and cannot therefore be deemed as being engineered, manufactured or setup to be compliant for implementation or for resale as device in High Risk Applications. All application and safety related information in this document (including application descriptions, suggested safety measures, suggested Kontron products, and other materials) is provided for reference only.

Revision History

Revision	Brief Description of Changes	Date of Issue
1.0	Initial Issue	2018-Mar-02
1.1	CN16 pin assignment update	2018-Apr-12
1.2	JP7 pin assignment update	2018-Jul-18
1.3	Update memory size	2018-Aug-07
1.4	Update mPCIe pin definition	2018-Nov-22
1.5	Update CN2 pin definition	2019-Jan-03
1.6	Update supply voltage description	2019-Jan-08
1.7	Update block diagram	2019-Jan-30
1.8	Update +12 VDC tolerance	2019-Jul-18
2.0	Model name renamed from ECX-SKL-U to 3.5"-SBC-SKL	2019-Dec-27
2.1	Add a LPS power supply notice in Sec. 2.1	2020-Apr-09
2.2	Modify SATA socket Q'ty	2021-Mar-09
2.3	Audio codec chip replacement	2021-Mar-30
2.4	Modify USB 3.0 to USB 3.2 Gen 1 per new naming	2022-Jul-29

Terms and Conditions

Kontron warrants products in accordance with defined regional warranty periods. For more information about warranty compliance and conformity, and the warranty period in your region, visit <https://www.kontron.com/terms-and-conditions>.

Kontron sells products worldwide and declares regional General Terms & Conditions of Sale, and Purchase Order Terms & Conditions. Visit <https://www.kontron.com/terms-and-conditions>.

For contact information, refer to the corporate offices contact information on the last page of this user guide or visit our website [CONTACT US](#).

Customer Support

Find Kontron contacts by visiting: <https://www.kontron.com/support>.

Customer Service

As a trusted technology innovator and global solutions provider, Kontron extends its embedded market strengths into a services portfolio allowing companies to break the barriers of traditional product lifecycles. Proven product expertise coupled with collaborative and highly-experienced support enables Kontron to provide exceptional peace of mind to build and maintain successful products.

For more details on Kontron's service offerings such as: enhanced repair services, extended warranty, Kontron training academy, and more visit <https://www.kontron.com/support-and-services/services>.

Customer Comments

If you have any difficulties using this user guide, discover an error, or just want to provide some feedback, contact [Kontron support](#). Detail any errors you find. We will correct the errors or problems as soon as possible and post the revised user guide on our website.

Symbols

The following symbols may be used in this user guide

⚠ DANGER

DANGER indicates a hazardous situation which, if not avoided, will result in death or serious injury.

⚠ WARNING

WARNING indicates a hazardous situation which, if not avoided, could result in death or serious injury.

NOTICE

NOTICE indicates a property damage message.

⚠ CAUTION

CAUTION indicates a hazardous situation which, if not avoided, may result in minor or moderate injury.



Electric Shock!

This symbol and title warn of hazards due to electrical shocks (> 60 V) when touching products or parts of products. Failure to observe the precautions indicated and/or prescribed by the law may endanger your life/health and/or result in damage to your material.



ESD Sensitive Device!

This symbol and title inform that the electronic boards and their components are sensitive to static electricity. Care must therefore be taken during all handling operations and inspections of this product in order to ensure product integrity at all times.



HOT Surface!

Do NOT touch! Allow to cool before servicing.



Laser!

This symbol inform of the risk of exposure to laser beam and light emitting devices (LEDs) from an electrical device. Eye protection per manufacturer notice shall review before servicing.



This symbol indicates general information about the product and the user guide.

This symbol also indicates detail information about the specific product configuration.



This symbol precedes helpful hints and tips for daily use.

For Your Safety

Your new Kontron product was developed and tested carefully to provide all features necessary to ensure its compliance with electrical safety requirements. It was also designed for a long fault-free life. However, the life expectancy of your product can be drastically reduced by improper treatment during unpacking and installation. Therefore, in the interest of your own safety and of the correct operation of your new Kontron product, you are requested to conform with the following guidelines.

High Voltage Safety Instructions

As a precaution and in case of danger, the power connector must be easily accessible. The power connector is the product's main disconnect device.

⚠ CAUTION

Warning

All operations on this product must be carried out by sufficiently skilled personnel only.

⚠ CAUTION



Electric Shock!

Before installing a non hot-swappable Kontron product into a system always ensure that your mains power is switched off. This also applies to the installation of piggybacks. Serious electrical shock hazards can exist during all installation, repair, and maintenance operations on this product. Therefore, always unplug the power cable and any other cables which provide external voltages before performing any work on this product.

Earth ground connection to vehicle's chassis or a central grounding point shall remain connected. The earth ground cable shall be the last cable to be disconnected or the first cable to be connected when performing installation or removal procedures on this product.

Special Handling and Unpacking Instruction

NOTICE



ESD Sensitive Device!

Electronic boards and their components are sensitive to static electricity. Therefore, care must be taken during all handling operations and inspections of this product, in order to ensure product integrity at all times.

Do not handle this product out of its protective enclosure while it is not used for operational purposes unless it is otherwise protected.

Whenever possible, unpack or pack this product only at EOS/ESD safe work stations. Where a safe work station is not guaranteed, it is important for the user to be electrically discharged before touching the product with his/her hands or tools. This is most easily done by touching a metal part of your system housing.

It is particularly important to observe standard anti-static precautions when changing piggybacks, ROM devices, jumper settings etc. If the product contains batteries for RTC or memory backup, ensure that the product is not placed on conductive surfaces, including anti-static plastics or sponges. They can cause short circuits and damage the batteries or conductive circuits on the product.

Lithium Battery Precautions

If your product is equipped with a lithium battery, take the following precautions when replacing the battery.

CAUTION

Danger of explosion if the battery is replaced incorrectly.

- ▶ Replace only with same or equivalent battery type recommended by the manufacturer.
- ▶ Dispose of used batteries according to the manufacturer's instructions.

General Instructions on Usage

In order to maintain Kontron's product warranty, this product must not be altered or modified in any way. Changes or modifications to the product, that are not explicitly approved by Kontron and described in this user guide or received from Kontron Support as a special handling instruction, will void your warranty.

This product should only be installed in or connected to systems that fulfill all necessary technical and specific environmental requirements. This also applies to the operational temperature range of the specific board version that must not be exceeded. If batteries are present, their temperature restrictions must be taken into account.

In performing all necessary installation and application operations, only follow the instructions supplied by the present user guide.

Keep all the original packaging material for future storage or warranty shipments. If it is necessary to store or ship the product then re-pack it in the same manner as it was delivered.

Special care is necessary when handling or unpacking the product. See Special Handling and Unpacking Instruction.

Quality and Environmental Management

Kontron aims to deliver reliable high-end products designed and built for quality, and aims to complying with environmental laws, regulations, and other environmentally oriented requirements. For more information regarding Kontron's quality and environmental responsibilities, visit <https://www.kontron.com/about-kontron/corporate-responsibility/quality-management>.

Disposal and Recycling

Kontron's products are manufactured to satisfy environmental protection requirements where possible. Many of the components used are capable of being recycled. Final disposal of this product after its service life must be accomplished in accordance with applicable country, state, or local laws or regulations.

WEEE Compliance

The Waste Electrical and Electronic Equipment (WEEE) Directive aims to:

- ▶ Reduce waste arising from electrical and electronic equipment (EEE)
- ▶ Make producers of EEE responsible for the environmental impact of their products, especially when the product become waste
- ▶ Encourage separate collection and subsequent treatment, reuse, recovery, recycling and sound environmental disposal of EEE
- ▶ Improve the environmental performance of all those involved during the lifecycle of EEE



Environmental protection is a high priority with Kontron.

Kontron follows the WEEE directive

You are encouraged to return our products for proper disposal.

Table of Contents

Symbols	7
For Your Safety	8
High Voltage Safety Instructions	8
Special Handling and Unpacking Instruction	8
Lithium Battery Precautions	9
General Instructions on Usage	9
Quality and Environmental Management	9
Disposal and Recycling	9
WEEE Compliance	9
Table of Contents	10
List of Tables	11
List of Figures	12
1/ Introduction	14
2/ Installation Procedures	15
2.1. Installing the Board	15
2.2. Chassis Safety Standards	16
2.3. Lithium Battery Replacement	16
3/ System Specifications	18
3.1. System Block Diagram	18
3.2. Component Main Data	19
3.3. Environmental Conditions	20
3.4. Standards and Certifications	20
3.5. Processor Support	21
3.6. System Memory Support	21
3.6.1. Memory Operating Frequencies	21
3.7. On-board Graphics Subsystem	22
3.8. Power Supply Voltage	23
4/ Connector Locations	24
4.1. Top Side	24
4.2. Rear Side	26
4.3. Connector Panel Side	27
5/ Connector Definitions	28
6/ I/O-Area Connectors	29
6.1. HDMI Connector (HDMI1)	29
6.2. DP Connector (DP1)	30
6.3. Ethernet Connectors (CN11 & CN12)	31
6.4. USB Connectors (I/O Area)	32
7/ Internal Connectors	34
7.1. Power Connector	34
7.1.1. Power Input Wafer (CN2)	34
7.1.2. RTC Power Input Wafer (BAT1)	34
7.2. Fan Wafer (FAN1)	35
7.3. SATA (Serial ATA) Disk Interfaces (SATA1 & SATA2)	36
7.4. HDD Power Output Wafer (CN1)	37
7.5. USB Connectors (Internal) (CN8)	38
7.6. Speaker Connector (CN10 & CN15)	39

7.7. Audio Connector (CN9)	39
7.8. Front Panel Pin Header (FP1 & FP2)	40
7.9. Serial COM1 - COM2 Ports (CN6 & CN7)	42
7.10. LVDS Flat Panel Connector (LVDS1)	43
7.11. LCD Panel Power Connector for LVDS1 (CN16)	45
7.12. Digital Input / Output Wafer (CN5)	46
7.13. mPCIe Slot Connector (MPCIE1)	47
7.14. NGFF M.2 Key B Slot Connector (CON1)	49
7.15. SIM Card Connector (CN4)	51
7.16. Switches and Jumpers	52
7.16.1. MPCIE1 Activity LED Pin Header (JP1)	52
7.16.2. Panel & Backlight Power Selection for LVDS1 (JP2)	53
7.16.3. NGFF M.2 Activity LED Pin Header (JP3)	53
7.16.4. Backlight Power Enable Selection for LVDS1 (JP4)	53
7.16.5. AT / ATX Power Mode & NGFF mSATA / mPCIe Selection (JP6)	54
7.16.6. SIM Card and USB Power Selection (JP7)	54
7.16.7. Flash Descriptor Security Override Selection (JP8)	55
7.16.8. RTC Reset Selection (JP9)	55
7.16.9. Clear ME Register (JP10)	56
8/ On-Board Connectors & Mating Connector Types	57
9/ BIOS	58
9.1. Starting the uEFI BIOS	58
9.2. Setup Menus	59
9.2.1. Main Setup Menu	59
9.2.2. Advanced Setup Menu	61
9.2.3. Power Setup Menu	72
9.2.4. Boot Setup Menu	74
9.2.5. Security Setup Menu	75
9.2.5.1. Remember the password	76
9.2.6. Save & Exit Setup Menu	77
Appendix A: List of Acronyms	78
About Kontron	79

List of Tables

Table 1: Component Main Data	19
Table 2: Environmental Conditions	20
Table 3: Standards and Certifications	20
Table 4: Processor Support	21
Table 5: Memory Operating Frequencies	22
Table 6: Three-displays Configurations	23
Table 7: Supply Voltages	23
Table 8: Jumper List	24
Table 9: Top Side Internal Connector Pin Assignment	24
Table 10: Rear Side Internal Connector Pin Assignment	26
Table 11: Connector Panel Side Connector List	27
Table 12: Pin Assignment HDMI Connector HDMI1	29
Table 13: Pin Assignment DP Connector DP1	30
Table 14: Pin Assignment Ethernet Connectors CN11, CN12	31
Table 15: Pin Assignment USB 3.2 Gen 1 Connectors CN13, CN14	32
Table 16: Signal Description	33

Table 17: Pin Assignment CN2.....	34
Table 18: Pin Assignment BAT1	34
Table 19: 4-pin Mode FAN1	35
Table 20: 3-pin Mode FAN1.....	35
Table 21: Signal description.....	35
Table 22: Pin Assignment SATA1, SATA2	36
Table 23: Signal Description.....	36
Table 24: Pin Assignment CN1	37
Table 25: Pin Assignment CN8	38
Table 26: Signal Description.....	38
Table 27: Pin Assignment CN8.....	39
Table 28: Pin Assignment CN8	39
Table 29: Pin Assignment FP1.....	40
Table 30: Signal Description.....	40
Table 31: Pin Assignment FP2	41
Table 32: Signal Description.....	41
Table 33: Pin Assignment CN6, CN7	42
Table 34: Signal Description	42
Table 35: Pin Assignment LVDS1.....	43
Table 36: Signal Description.....	44
Table 37: Pin Assignment CN16.....	45
Table 38: Signal Description	45
Table 39: Pin Assignment FP2	46
Table 40: Signal Description	46
Table 41: Pin Assignment MPCIE1.....	47
Table 42: Pin Assignment CON1.....	49
Table 43: Pin Assignment CN4	51
Table 44: Pin Assignment JP1	52
Table 45: Pin Assignment JP1.....	53
Table 46: Pin Assignment JP3.....	53
Table 47: Pin Assignment JP4.....	54
Table 48: Pin Assignment JP6.....	54
Table 49: Pin Assignment JP7.....	54
Table 50: Pin Assignment JP8.....	55
Table 51: Pin Assignment JP9.....	55
Table 52: Pin Assignment JP10	56
Table 53: On-Board Connectors & Mating Connector Types	57
Table 54: Font Size Table	58
Table 55: Main Setup Menu Sub-Screens and Functions	59
Table 56: List of Acronym.....	78

List of Figures

Figure 1: System Block Diagram 3.5"-SBC-SKL	18
Figure 2: Top Side	24
Figure 3: Rear Side.....	26
Figure 4: Connector Panel Side	27
Figure 5: HDMI Connector HDMI1.....	29
Figure 6: DP Connector DP1	30
Figure 7: Ethernet Connectors CN11, CN12	31
Figure 8: USB 3.2 Gen 1 Connectors CN13, CN14	32
Figure 9: USB 2.0 High Speed Cable.....	33
Figure 10: USB 3.2 High Speed Cable	33
Figure 11: Power Input Wafer CN2.....	34
Figure 12: RTC Power Input Wafer BAT1	34
Figure 13: Fan Wafer FAN1.....	35

Figure 14: SATA Connector SATA1, SATA2	36
Figure 15: HDD Power Output Wafer CN1	37
Figure 16: USB 2.0 Pin Header CN8.....	38
Figure 17: 3W Audio AMP Output Wafer CN10 (Left Channel), CN15 (Right Channel)	39
Figure 18: Audio Input / Output Pin Header CN9	39
Figure 19: Front Panel Pin Header FP1	40
Figure 20: Front Panel Pin Header FP2.....	40
Figure 21: Serial COM CN6, CN7	42
Figure 22: LVDS Connector LVDS1	43
Figure 23: LCD Panel Power Connector CN16	45
Figure 24: Digital Input / Output Wafer CN5.....	46
Figure 25: mPCIe Slot Connector MPCIE1.....	47
Figure 26: NGFF M.2 Key B Slot Connector CON1.....	49
Figure 27: SIM Interface Wafer CN4	51
Figure 28: Jumper Connector	52
Figure 29: MPCIE1 Activity LED Pin Header JP1	52
Figure 30: Panel & Backlight Power Selection for LVDS1 (JP2)	53
Figure 31: NGFF M.2 Activity LED Pin Header (JP3)	53
Figure 32: Backlight Power Enable Selection for LVDS1 (JP4)	53
Figure 33: AT / ATX Power Mode & NGFF mSATA / mPCIe Selection (JP6)	54
Figure 34: SIM Card and USB Power Selection (JP7).....	54
Figure 35: Flash Descriptor Security Override Selection (JP8)	55
Figure 36: RTC Reset Selection (JP9).....	55
Figure 37: Clear ME Register (JP10)	56
Figure 38: BIOS Main Menu Screen System Data and Time.....	60
Figure 39: BIOS Advanced Menu.....	62
Figure 40: BIOS Advanced Menu - Display Configuration	63
Figure 41: BIOS Advanced Menu - Super IO Configuration	65
Figure 42: BIOS Advanced Menu - Super IO Configuration - Serial Port 1 Configuration	65
Figure 43: BIOS Advanced Menu - Super IO Configuration - Serial Port 2 Configuration.....	66
Figure 44: BIOS Advanced Menu - CPU Chipset Configuration	67
Figure 45: BIOS Advanced Menu - SATA Configuration	68
Figure 46: BIOS Advanced Menu - USB Configuration	69
Figure 47: BIOS Advanced Menu - DIO Configuration.....	70
Figure 48: BIOS Advanced Menu - H/W Monitor	71
Figure 49: BIOS Power Setup Menu.....	72
Figure 50: BIOS Power Setup Menu - WatchDog Timer Configuration.....	73
Figure 51: BIOS Boot Setup Menu	74
Figure 52: BIOS Boot Setup Menu.....	75
Figure 53: BIOS Boot Setup Menu.....	77

1/ Introduction

This user guide describe the 3.5"-SBC-SKL board made by Kontron. This board will also be denoted 3.5"-SBC-SKL within this user guide.

Use of this user guide implies a basic knowledge of PC-AT hardware and software. This user guide focuses on describing the 3.5"-SBC-SKL board's special features and is not intended to be a standard PC-AT textbook.

New users are recommended to study the short installation procedure stated in the following chapter before switching on the power.

All configuration and setup of the CPU board is either carried out automatically or manually by the user via the BIOS setup menus.

Latest revision of this user guide, datasheet, thermal simulations, BIOS, drivers, BSP's (Board Support Packages), mechanical drawings (2D and 3D) can be download from Kontron's Web Page.

2/ Installation Procedures

2.1. Installing the Board

NOTICE



ESD Sensitive Device

Electrostatic discharge (ESD) can damage equipment and impair electrical circuitry.

- ▶ Wear ESD-protective clothing and shoes
- ▶ Wear an ESD-preventive wrist strap attached to a good earth ground
- ▶ Check the resistance value of the wrist strap periodically (1 MΩ to 10 MΩ)
- ▶ Transport and store the board in its antistatic bag
- ▶ Handle the board at an approved ESD workstation
- ▶ Handle the board only by the edges

To get the board running follow these steps. If the board shipped from KONTRON already has components like RAM and CPU cooler mounted, then skip the relevant steps below.

1. Turn off the PSU (Power Supply Unit)

NOTICE

Turn off PSU (Power Supply Unit) completely (no mains power connected to the PSU) or leave the Power Connectors unconnected while configuring the board. Otherwise, components (RAM, LAN cards etc.) might get damaged. Make sure to use +12 V DC single supply only. Alternatively, use a standard ATX PSU with suitable cable kit and PS-ON# active.

NOTICE

The power supply unit shall comply with the requirements as defined in IEC 62368-1 according Clause 6.2.2 to power source category PS2 "Limited Power Source".

2. Insert the DDR4 2133 module(s)

Be careful to push the memory module in the slot(s) before locking the tabs. Use SO-DIMM with the same memory density in both sockets!

3. Connecting interfaces

Insert all external cables for hard disk, keyboard etc. A monitor must be connected in order to change BIOS settings.

4. Connect and turn on PSU

Connect PSU to the board by the +12 V 3.0mm pitch 1x4-pin wafer connector.

5. BIOS setup

Enter the BIOS setup by pressing the key during boot up.

Enter "Exit Menu" and Load Setup Defaults.



To clear all BIOS setting, including Password protection, activate "Clear CMOS Jumper" for 10 sec (without power connected).

6. Mounting the board in chassis

NOTICE

When mounting the board to chassis etc. please note that the board contains

components on both sides of the PCB that can easily be damaged if board is handled without reasonable care. A damaged component can result in malfunction or no function at all.

When fixing the board on a chassis, it is recommended to use screws with an integrated washer and a diameter of > 7 mm. Do not use washers with teeth, as they can damage the PCB and cause short circuits.

2.2. Chassis Safety Standards

Before installing the 3.5"-SBC-SKL in the chassis, users must evaluate the end product to ensure compliance with the requirements of the IEC60950-1 safety standard:

- ▶ The board must be installed in a suitable mechanical, electrical and fire enclosure.
- ▶ The system, in its enclosure, must be evaluated for temperature and airflow considerations.
- ▶ The board must be powered by a CSA or UL approved power supply that limits the maximum input current.
- ▶ For interfaces having a power pin such as external power or fan, ensure that the connectors and wires are suitably rated. All connections from and to the product shall be with SELV circuits only.
- ▶ Wires have suitable rating to withstand the maximum available power.
- ▶ The peripheral device enclosure fulfils the IEC60950-1 fire protecting requirements.

2.3. Lithium Battery Replacement

If replacing the lithium battery follow the replacement precautions stated in the notification below:

⚠ CAUTION

Danger of explosion if the lithium battery is incorrectly replaced.

- ▶ Replace only with the same or equivalent type recommended by the manufacturer
- ▶ Dispose of used batteries according to the manufacturer's instructions

VORSICHT! Explosionsgefahr bei unsachgemäßem Austausch der Batterie.

- ▶ Ersatz nur durch denselben oder einen vom Hersteller empfohlenen gleichwertigen Typ
- ▶ Entsorgung gebrauchter Batterien nach Angaben des Herstellers

ATTENTION! Risque d'explosion avec l'échange inadéquat de la batterie.

- ▶ Remplacement seulement par le même ou un type équivalent recommandé par le producteur
- ▶ L'évacuation des batteries usagées conformément à des indications du fabricant

PRECAUCION! Peligro de explosi3n si la bater3a se sustituye incorrectamente.

- ▶ Sustituya solamente por el mismo o tipo equivalente recomendado por el fabricante
- ▶ Disponga las bater3as usadas seg3n las instrucciones del fabricante

ADVARSEL! Lithiumbatteri – Eksplosjonsfare ved feilagtig h3ndtering.

- ▶ Udsiftning m3 kun ske med batteri af samme fabrikat og type
- ▶ Lev3r det brugte batteri tilbage til leverand3ren

ADVARSEL! Eksplosjonsfare ved feilaktig skifte av batteri.

- ▶ Benytt samme batteritype eller en tilsvarende type anbefalt av apparatfabrikanten
- ▶ Brukte batterier kasseres i henhold til fabrikantens instruksjoner

WARNING! Explosionsfara vid felaktigt batteribyte.

- ▶ Anv3nd samma batterityp eller en ekvivalent typ som rekommenderas av apparattillverkaren
-

- ▶ Kassera använt batteri enligt fabrikantens instruktion

VAROITUS! Paristo voi räjähtää, jos se on virheellisesti asennettu.

- ▶ Vaihda paristo ainoastaan lalteval- mistajan suosittelemaan tyyppiln
 - ▶ Hävitä käytetty paristo valmistajan ohjeiden mukaisesti
-

3/ System Specifications

3.1. System Block Diagram

Figure 1: System Block Diagram 3.5"-SBC-SKL

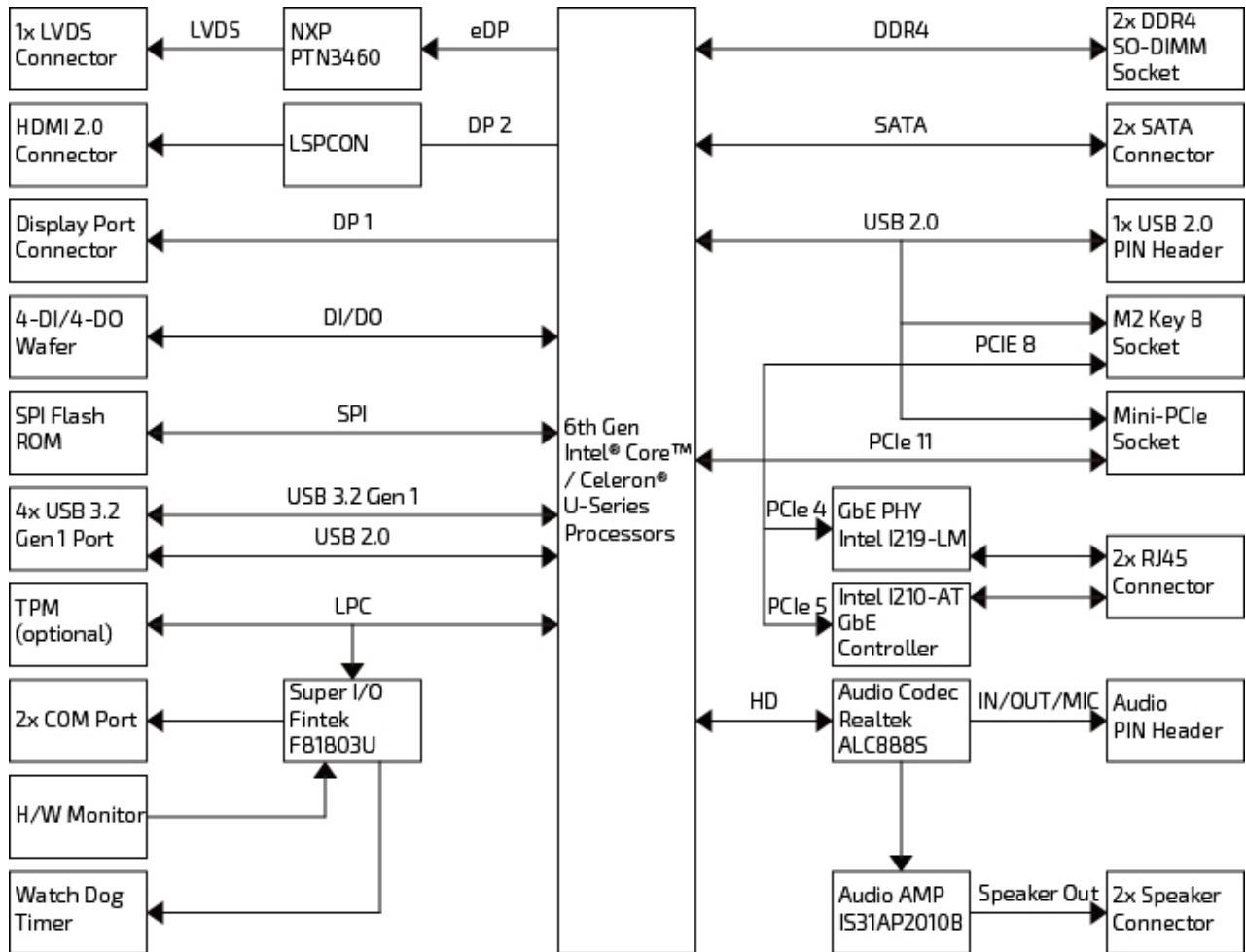

3.2. Component Main Data

The table below summarizes the features of the 3.5"-SBC-SKL single board computer.

Table 1: Component Main Data

System	
Processor	6th Generation Intel® Core™ / Celeron® U-Series Processors (TDP = 15 W)
Memory	2x DDR4 SO-DIMM memory socket
Video	
Display Interface	<ul style="list-style-type: none"> ▶ 1x LVDS (24-bit, 2-ch) ▶ 1x HDMI 2.0 (on rear, 3840 x 2160 @ 60 Hz) ▶ 1x DP (on rear, 4096 x 2304 @ 60 Hz)
Multiple Display	Triple
Audio	
Audio Codec	Realtek ALC888S
Audio Interface	<ul style="list-style-type: none"> ▶ 1x Speaker-out (Stereo, 3 W, by header) ▶ 1x Line-in (by header) ▶ 1x Line-out (by header) ▶ 1x Mic-in (by header)
Network Connection	
Ethernet	2x GbE LAN (RJ-45 on rear, 1x Intel® I219-LM, 1x Intel® I210-AT)
Peripheral Connection	
USB	<ul style="list-style-type: none"> ▶ 4x USB 3.2 Gen 1 (Type A on rear) ▶ 2x USB 2.0 (by header)
Serial Port	2x RS232/422/485 (by header, w/ auto flow control for RS485)
Other I/Os	8x DIO (by header)
Storage & Expansion	
Storage & Expansion	<ul style="list-style-type: none"> ▶ 1x SATA 3.0 (for models w/ Celeron® CPU & w/o TPM) ▶ 2x SATA 3.0 (for other models) ▶ 1x mPCIe (full size) ▶ 1x M.2 Key B Socket (Type 2242, w/ SATA 3.0 / USB 2.0) ▶ 1x SIM Card Cage (by wafer, switchable for mPCIe or M.2)
Power	
Input Voltage	DC 12 V
Connector	1x4-pin Wafer (Straight & Right Angle dual-footprint)
Firmware	
BIOS	AMI uEFI BIOS w/ 128 Mb SPI Flash
Watchdog	Programmable WDT to generate system reset event
H/W Monitor	Voltages, Temperatures
Real Time Clock	Processor integrated RTC
Security	▶ TPM 1.2 (Supported by default for models with Core™ i5 / i7 CPU, optional for others, Infineon SLB 9660)
iAMT	Supported for models with Core™ i5 / i7 CPU

System Control & Monitoring	
FP Header	<ul style="list-style-type: none"> ▶ 1x Header for Reset button, HDD LED & External Speaker ▶ 1x Header for Power button, Power LED & SM bus ▶ 1x Header for mPCIe activity LED ▶ 1x Header for M.2 activity LED
Cooling	
FAN	1x header for System Fan
Software	
OS Support	Windows 7, Windows 8, Windows 10, Linux
Mechanical	
Dimension (L x W)	3.5" ECX (146 x 105 mm / 5.75" x 4.13")

3.3. Environmental Conditions

The 3.5"-SBC-SKL is compliant with the following environmental conditions. It is the customer's responsibility to provide sufficient airflow around each of the components to keep them within the allowed temperature range.

Table 2: Environmental Conditions

Operating Temperature	0 °C ~ 60 °C / 32 °F ~ 140 °F (Standard) -20 °C ~ 70 °C / -4 °F ~ 158 °F (Extended)
Storage Temperature	-20 °C ~ 80 °C / -4 °F ~ 176 °F (Standard) -40 °C ~ 85 °C / -40 °F ~ 185 °F (Extended)
Humidity	0 % ~ 95 %

3.4. Standards and Certifications

The 3.5"-SBC-SKL meets the following standards and certification tests.

Table 3: Standards and Certifications

CE (Class B)	<ul style="list-style-type: none"> ▶ EN55032:2015 + AC: 2016-07 ▶ AS/NZS CISPRE 32: 2015 ▶ EN 61000-3-2: 2014 ▶ EN 61000-3-3: 2013 ▶ EN 55024: 2010 + A1: 2015 ▶ EN 61000-4-2: 2009 ▶ EN 61000-4-3: 2010 ▶ EN 61000-4-4: 2012 ▶ EN 61000-4-5: 2017 ▶ EN 61000-4-6: 2014 ▶ EN 61000-4-8: 2010 ▶ EN 61000-4-11: 2017
FCC (Class B)	<ul style="list-style-type: none"> ▶ FCC CFR Title 47 Part 15 Subpart B ▶ CISPR 22

3.5. Processor Support

The 3.5"-SBC-SKL is designed to support 6th Generation Intel® Core™ / Celeron® U-Series Processors. The BGA CPU is remounted from factory. Kontron has defined the board versions as listed in the following table, so far all based on Embedded CPUs. Other versions are expected at a later date.

Table 4: Processor Support

Name	Core #	Speed	Turbo	Embedded	Cache	Socket	TDP	Tj
Core™ i7-6600U	2	2.60 GHz	3.40 GHz	Yes	4M	FCBGA1356	15W	100°C
Core™ i5-6300U	2	2.40 GHz	3.00 GHz	Yes	3M	FCBGA1356	15W	100°C
Celeron® 3955U	2	2.00 GHz	-	Yes	2M	FCBGA1356	15W	100°C

Sufficient cooling must be applied to the CPU in order to remove the effect as listed as TDP (Thermal Design Power) in above table. The sufficient cooling is also depending on the worst case maximum ambient operating temperature and the actual worst case load of processor.

3.6. System Memory Support

The 3.5"-SBC-SKL has two DDR4 SO-DIMM sockets. The sockets support the following memory features:

- ▶ 2x DDR4 1.2V SO-DIMM 260-pin
- ▶ Dual-channel with 1x SO-DIMM per channel
- ▶ From 1GB and up to 2x 16GB
- ▶ Single / dual rank unbuffered 2133 MT/s (PC4-17000)
- ▶ SPD timing supported
- ▶ ECC not supported



If only one SO-DIMM is used, then slot DIMM1 must be used as the primary slot (ChannelA).

If DIMM2 (Channel B) is populated, then the board will not boot.



If using 32bit OS then less than 4GB is displayed in System (Shared Video Memory/PCI resources is subtracted). Use SO-DIMM with the same memory density in both sockets!

The installed DDR4 SO-DIMM should support the Serial Presence Detect (SPD) data structure. This allows the BIOS to read and configure the memory controller for optimal performance. If non-SPD memory is used, the BIOS will attempt to configure the memory settings, but performance and reliability may be impacted, or the board may not be able to boot totally.

3.6.1. Memory Operating Frequencies

In all modes, the frequency of system memory is the lowest frequency of all the memory modules placed in the system. Each memory module's frequency can be determined through the SPD registers on the memory modules.

The table below lists the resulting operating memory frequencies based on the combination of SO-DIMMs and processor.

Table 5: Memory Operating Frequencies

SO-DIMM Type	Module Name	Memory Data Transfer (MT/s)	Processor System Bus Frequency (MHz)	Resulting Memory Clock Frequency (MHz)	Peak Transfer Rate (MB/s)
DDR4 2133	PC4-17000	2133	1066	266	17066

Memory modules have in general a much lower longevity than embedded motherboards, and therefore EOL of modules can be expected several times during lifetime of the motherboard. Kontron guarantees that the above P/N will be maintained so that EOL module will be replaced by other similar type of qualified module.

As a minimum it is recommend using Kontron memory modules for prototype system(s) in order to prove stability of the system and as for reference.

For volume production you might request to test and qualify other types of RAM. In order to qualify RAM it is recommend configuring 3 systems running RAM Stress Test program in heat chamber at 60° C for a minimum of 24 hours.

3.7. On-board Graphics Subsystem

The 3.5"-SBC-SKL supports Intel® Gen 9 / Gen 9.5 HD Graphics technology for high quality graphics capabilities. All 3.5"-SBC-SKL versions support three displays pipes. The DP interface supports the DisplayPort 1.2a specification. The PCH supports High-bandwidth Digital Content Protection for high definition content playback over digital interfaces. The PCH also integrates audio codecs for audio support over DP interfaces.

Up to three displays can be used simultaneously and be used to implement independent or cloned display configuration.

Intel® HD Graphics

Features of the Intel® HD Graphics include:

- ▶ High quality graphics engine supporting
 - ▶ 3 Symmetric Pipe Support
 - ▶ DirectX12 and OpenGL 4.x compliant and lower
 - ▶ Full H.265, H.264, MPEG2, MVC, WMV9 HW Decode
 - ▶ VP8 Decode HW Acceleration
 - ▶ Advanced Scheduler 2.0, 1.0, XPDM support
 - ▶ DirectX12, OpenGL 4.4, OpenCL 2.1 support
- ▶ DP
 - ▶ 24bit colours in 4096x2304 @ 60 Hz
 - ▶ DisplayPort standard 1.2a
- ▶ HDMI
 - ▶ 24bit colours in 3840x2160 @ 60 Hz
 - ▶ HDMI standard 2.0a
- ▶ LVDS
 - ▶ two pixels per clock, up to 1920x1200 - 24b bit colors
 - ▶ 12V for backlight, up to 2.5A
 - ▶ 3.3V or 5V for panel power, up to 1.0A
 - ▶ PWM Brightness/Dimming
 - ▶ VESA and JEIDA color coding

Table 6: Three-displays Configurations

Display 1	Display 2	Display 3	Max. Resolution (Px) at 60 Hz		
			Display 1	Display 2	Display 3
LVDS	DP	HDMI	1920x1200	4096x2304	3840x2160

Use of DP Adapter Converters (3rd party accessories) can provide HDMI panel support.

The DP to HDMI supports the HDMI 1.4a specification including audio codec.



Supporting 4K display requires two DDR channels of the same size. Performance degradations exists while running 4K content for systems using single channel system memory (compared to using dual channel).

High-Bandwidth Digital Content Protection (HDCP)

HDCP is the technology used to protecting high-definition content against unauthorized copying or interception between the source (computer, digital set top boxes, and so on) and the sink (panels, monitor, and TVs). The 3.5"-SBC-SKL supports HDCP 2.2 for content protection over-wired displays (HDMI, DVI, and DP). The HDCP 1.4 keys are integrated into the processor and customers are not required to physically configure or handle the keys.

3.8. Power Supply Voltage

In order to ensure safe operation of the board, the input power supply must monitor the supply voltage and shut down if the supply is out of range – refer to the actual power supply specification. Please note, in order to keep the power consumption to a minimal level, boards do not implement a guaranteed minimum load. The 3.5"-SBC-SKL board must be powered through the 3.0 mm pitch 1x4-pin wafer connector from a DC 12 V power supply.

NOTICE

Hot Plugging power supply is not supported. Hot plugging might damage the board.

The requirements to the supply voltages are as follows:

Table 7: Supply Voltages

Supply	Min.	Max.	Note
+12 V	11.4 V	12.6 V	Should be $\pm 5\%$ tolerance

4/ Connector Locations

4.1. Top Side

Figure 2: Top Side

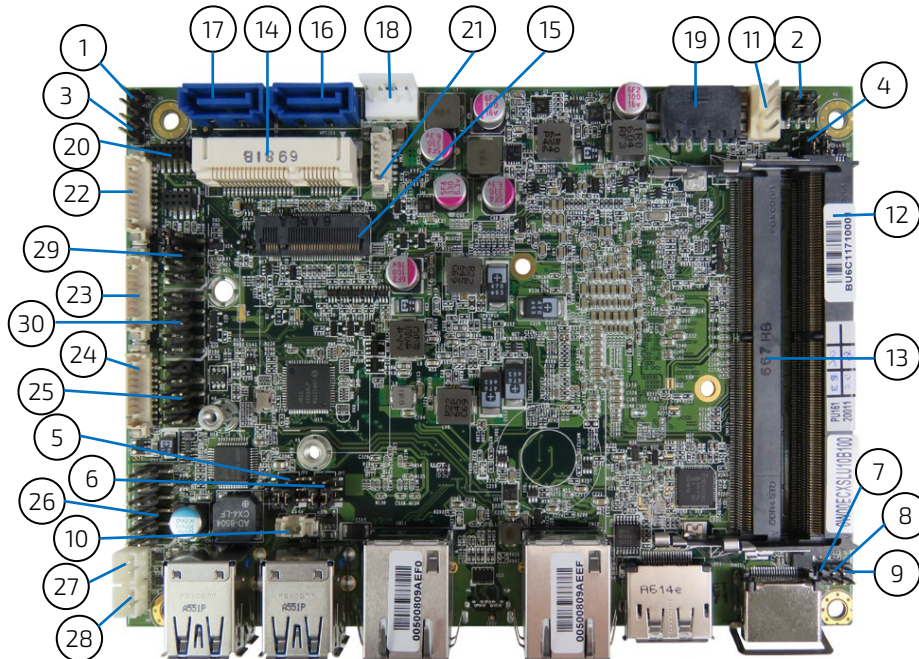

Table 8: Jumper List

Item	Designation	Description	See Chapter
1	JP1	MPCIE1 Activity LED Pin Header	7.16.1
2	JP2	Panel & Backlight Power Selection for LVDS1	7.16.2
3	JP3	NGFF M.2 Activity LED Pin Header	7.16.3
4	JP4	Backlight Power Enable Selection for LVDS1	7.16.4
5	JP6	AT / ATX Power Mode and NGFF mSATA/mPCIe Selection	7.16.5
6	JP7	SIM Card and USB Power Selection	7.16.6
7	JP8	Flash Descriptor Security Override Selection	7.16.7
8	JP9	RTC Reset Selection	7.16.8
9	JP10	Clear ME Register	7.16.9

Table 9: Top Side Internal Connector Pin Assignment

Item	Designation	Description	See Chapter
10	BAT1	RTC Power Input Wafer	7.1.2
11	FAN1	+12VDC CPU FAN Wafer	7.2
12	DIMM1	Primary DDR4 Memory SO-DIMM Socket	
13	DIMM2	Secondary DDR4 Memory SO-DIMM Socket	
14	MPCIE1	Full Size Mini-PCI Express v1.2 Socket	7.13
15	CON1	NGFF M.2 Key-B Socket	7.14
16	SATA1	Serial ATA Port-0 SATA Socket	7.3

Item	Designation	Description	See Chapter
17	SATA2	Serial ATA Port-0 SATA Socket	7.3
18	CN1	HDD Power Output Wafer	7.4
19	CN2	DC12V Power Input Wafer	7.1.1
20	CN3	P80 Header	
21	CN4	SIM Interface Wafer for MPCIE1/NGFF M.2	7.15
22	CN5	Digital Input / Output Wafer	7.12
23	CN6	Serial Port 1 Wafer	7.9
24	CN7	Serial Port 2 Wafer	7.9
25	CN8	USB 2.0 Port DN5,6 Pin Header	7.5
26	CN9	Audio Input / Output Pin Header	7.7
27	CN10	Left Channel 3W Audio AMP Output Wafer	7.6
28	CN15	Right Channel 3W Audio AMP Output Wafer	7.6
29	FP1	Front Panel 1 Pin Header	7.8
30	FP2	Front Panel 2 Pin Header	7.8

4.2. Rear Side

Figure 3: Rear Side

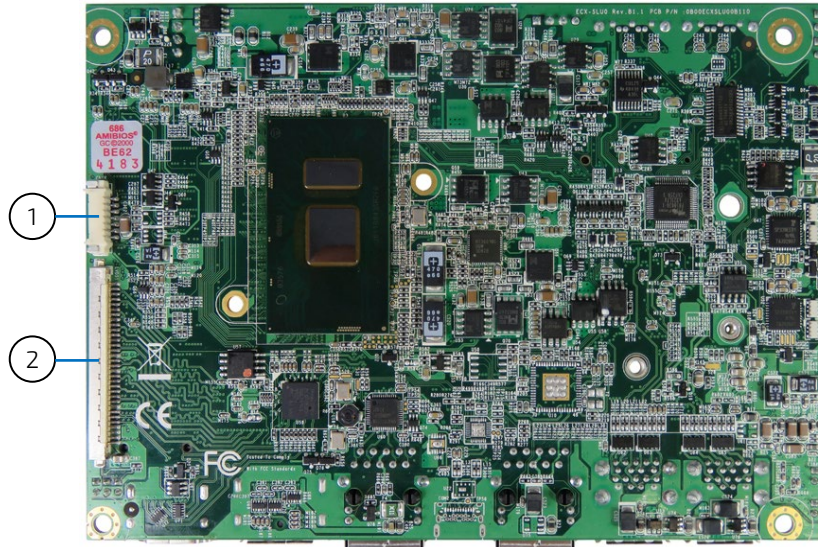

Table 10: Rear Side Internal Connector Pin Assignment

Item	Designation	Description	See Chapter
1	CN16	LCD Panel Power Connector	7.11
2	LVDS1	LVDS Panel Connector	7.10

4.3. Connector Panel Side

Figure 4: Connector Panel Side

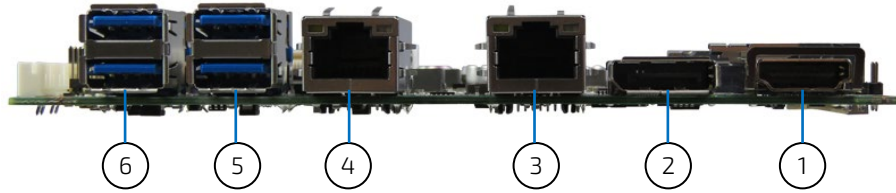

Table 11: Connector Panel Side Connector List

Item	Designation	Description	See Chapter
1	HDMI1	HDMI Port-1 Connector	6.1
2	DP1	DisplayPort Port-1 Connector	6.2
3	CN12	GbE LAN1 RJ-45 Connector	6.3
4	CN11	GbE LAN2 RJ-45 Connector	6.3
5	CN13	USB 3.2 Gen 1 Port-1,2 Type-A Connector	6.4
6	CN14	USB 3.2 Gen 1 Port-3,4 Type-A Connector	6.4

5/ Connector Definitions

The following defined terms are used within this user guide to give more information concerning the pin assignment and to describe the connector's signals.

Defined Term	Description
Pin	Shows the pin numbers in the connector
Signal	The abbreviated name of the signal at the current pin The notation "XX#" states that the signal "XX" is active low
Note	Special remarks concerning the signal
Designation	Type and number of item described
See Chapter	Number of the chapter within this user guide containing a detailed description

The abbreviation TBD is used for specifications that are not available yet or which are not sufficiently specified by the component vendors.

6/ I/O-Area Connectors

6.1. HDMI Connector (HDMI1)

The HDMI connector is based on standard HDMI type A.

Figure 5: HDMI Connector HDMI1

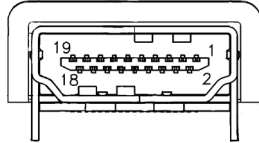

Table 12: Pin Assignment HDMI Connector HDMI1

Pin	Signal	Description	Note
1	TMD_DATA2+		
2	GND		
3	TMD_DATA2-		
4	TMD_DATA1+		
5	GND		
6	TMD_DATA1-		
7	TMD_DATA0+		
8	GND		
9	TMD_DATA0-		
10	TMD_CLK+		
11	GND		
12	TMD_CLK-		
13	CEC		
14	RESERVED		
15	DDC_CLK		
16	DDC_DATA		
17	GND		
18	5V		
19	HPET		

6.2. DP Connector (DP1)

The DP (DisplayPort) connector is based on standard DP female port.

Figure 6: DP Connector DP1

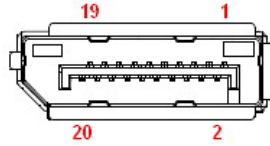

Table 13: Pin Assignment DP Connector DP1

Pin	Signal	Description	Note
1	TX0+		
2	GND		
3	TX0-		
4	TX1+		
5	GND		
6	TX1-		
7	TX2+		
8	GND		
9	TX2-		
10	TX3+		
11	GND		
12	TX3-		
13	GND		
14	GND		
15	AUX+		
16	GND		
17	AUX-		
18	HPD		
19	GND		
20	PWR		

6.3. Ethernet Connectors (CN11 & CN12)

The 3.5"-SBC-SKL supports two channels of 10/100/1000 Mbit Ethernet, which are based Intel® I219-LM, and Intel® I210-AT controllers respectively.

In order to achieve the specified performance of the Ethernet port, Category 5 twisted pair cables must be used with 10/100 MByte and Category 5E, 6 or 6E with 1 Gbit LAN networks.

The signals for the Ethernet ports are as follows:

Figure 7: Ethernet Connectors CN11, CN12

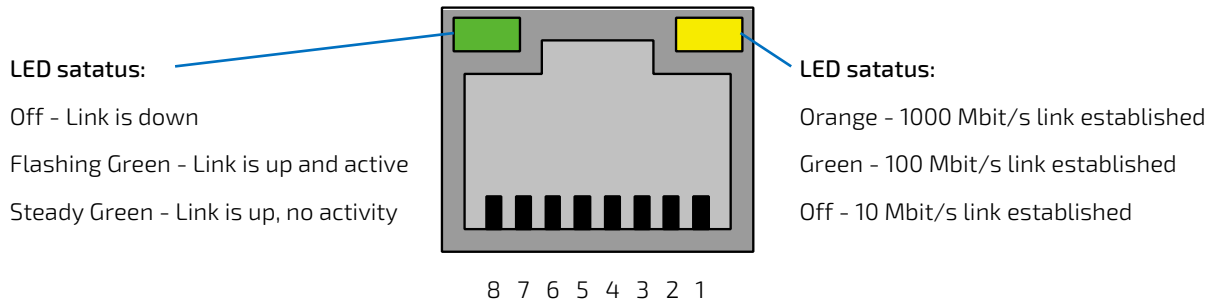

Table 14: Pin Assignment Ethernet Connectors CN11, CN12

Pin	Signal	Note
1	TX1+	
2	TX1-	
3	TX2+	
4	TX3+	
5	TX3-	
6	TX2-	
7	TX4+	
8	TX4-	

Signal Description

Signal	Description
TX1+ / TX1-	In MDI mode, this is the first pair in 1000Base-T, i.e. the BI_DA+/- pair, and is the transmit pair in 10Base-T and 100Base-TX. In MDI crossover mode, this pair acts as the BI_DB+/- pair, and is the receive pair in 10Base-T and 100Base-TX.
TX2+ / TX2-	In MDI mode, this is the second pair in 1000Base-T, i.e. the BI_DB+/- pair, and is the receive pair in 10Base-T and 100Base-TX. In MDI crossover mode, this pair acts as the BI_DA+/- pair, and is the transmit pair in 10Base-T and 100Base-TX.
TX3+ / TX3-	In MDI mode, this is the third pair in 1000Base-T, i.e. the BI_DC+/- pair. In MDI crossover mode, this pair acts as the BI_DD+/- pair.
TX4+ / TX4-	In MDI mode, this is the fourth pair in 1000Base-T, i.e. the BI_DD+/- pair. In MDI crossover mode, this pair acts as the BI_DC+/- pair.

'MDI' – media dependent Interface

6.4. USB Connectors (I/O Area)

The 3.5"-SBC-SKL contains an xHCI (Enhanced Host Controller Interface) controller that supports four USB 3.2 Gen 1 ports allowing data transfer up to 5Gb/s. Four of the USB 3.2 Gen 1 ports are shared with four of the USB 2.0 ports (Port 1 - Port 4).



Not all USB 2.0 and USB 3.2 Gen 1 ports are physically connected to the board.
USB 3.2 Gen 1 ports are backward compatible with USB 2.0.

Figure 8: USB 3.2 Gen 1 Connectors CN13, CN14

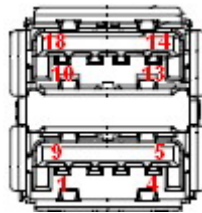

Table 15: Pin Assignment USB 3.2 Gen 1 Connectors CN13, CN14

Pin	Signal	Note
Top		
18	USBB_TX+	USB 3.2 Gen 1 Tx. Differential Pair (+)
17	USBB_TX-	USB 3.2 Gen 1 Tx. Differential Pair (-)
16	GND	
15	USBB_RX+	USB 3.2 Gen 1 Tx. Differential Pair (+)
14	USBB_RX-	USB 3.2 Gen 1 Tx. Differential Pair (-)
13	GND	
12	USBB_D-	USB 2.0 Differential Pair (+)
11	USBB_D-	USB 2.0 Differential Pair (-)
10	+USBB_VCC*	+5 V Supply for USB device
Bottom		
9	USBA_TX+	USB 3.2 Gen 1 Tx. Differential Pair (+)
8	USBA_TX-	USB 3.2 Gen 1 Tx. Differential Pair (-)
7	GND	
6	USBA_RX+	USB 3.2 Gen 1 Tx. Differential Pair (+)
5	USBA_RX-	USB 3.2 Gen 1 Tx. Differential Pair (-)
4	GND	
3	USBA_D-	USB 2.0 Differential Pair (+)
2	USBA_D-	USB 2.0 Differential Pair (-)
1	+USBA_VCC*	+5 V Supply for USB device



* The power source of +USBVCC can be selected by JP7.

Table 16: Signal Description

Signal	Description
USB _n _TX+, USB _n _TX-, USB _n _RX+, USB _n _RX-, USB _n _D-, USB _n _D-	Differential pair works as serial differential receive/transmit data lines. (n= A, B)
+USB _n _VCC	5 V supply for external devices. VCC is supplied during power-down to allow wakeup on USB device activity. Protected by a 1A current limiting IC covering each of the USB port. (n= A, B)

For HiSpeed rates it is required to use a USB cable, which is specified in USB 2.0 standard:

Figure 9: USB 2.0 High Speed Cable

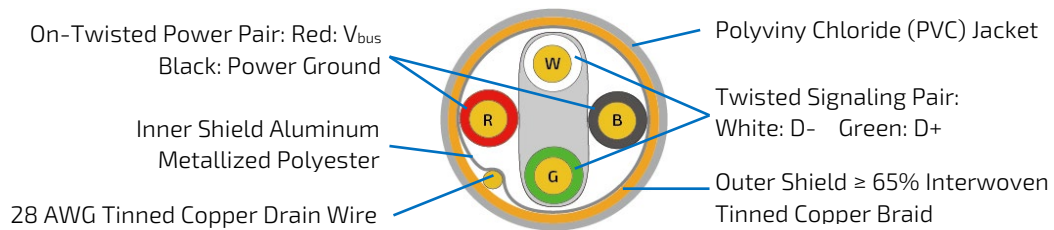

For USB 3.2 Gen 1 cabling it is required to use only HiSpeed USB cable, specified in USB 3.2 standard:

Figure 10: USB 3.2 High Speed Cable

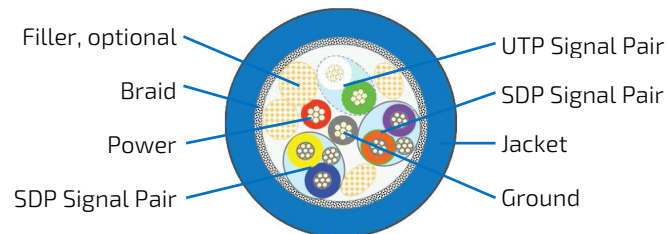

7/ Internal Connectors

7.1. Power Connector

Power connector must be used to supply the board with +12 VDC ($\pm 5\%$).

NOTICE

Hot plugging any of the power connector is not allowed.

Hot plugging might damage the board. In other words, turn off main supply etc. to make sure all the power lines are turned off when connecting to the motherboard.

7.1.1. Power Input Wafer (CN2)

Figure 11: Power Input Wafer CN2

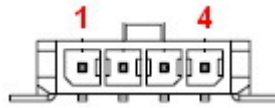

Table 17: Pin Assignment CN2

Pin	Signal	Description
1	+12V	Power +12 V
2	GND	Ground
3	GND	Ground
4	+5V	Power +12V

7.1.2. RTC Power Input Wafer (BAT1)

Figure 12: RTC Power Input Wafer BAT1

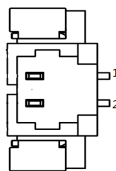

Table 18: Pin Assignment BAT1

Pin	Signal	Description
1	+VBAT	Battery supply for RTC
2	GND	Ground

7.2. Fan Wafer (FAN1)

The CPU FAN Wafer (FAN1) is used for the connection of the FAN for the CPU.

The 4-pin wafer is recommended to be used for driving 4-wire type FAN in order to implement FAN speed control. 3-wire Fan support is also possible, but no fan speed control is integrated.

Figure 13: Fan Wafer FAN1

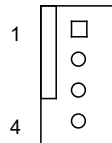

Table 19: 4-pin Mode FAN1

Pin	Signal	Description
1	GND	Ground
2	+12V	Power +12 V
3	SENSE	Sense signal
4	PWM	PWM output

Table 20: 3-pin Mode FAN1

Pin	Signal	Description
1	GND	Ground
2	+12V	Power +12 V
3	SENSE	Sense signal
4	-	Not used

Table 21: Signal description

Signal	Description
GND	Power Supply GND signal
12 V	+12 V supply for fan. A maximum of 2000 mA can be supplied from this pin.
SENSE	Sense input signal from the fan, for rotation speed supervision RPM (Rotations Per Minute). The signal shall be generated by an open collector transistor or similar.
PWM	PWM output signal for FAN speed control.

7.3. SATA (Serial ATA) Disk Interfaces (SATA1 & SATA2)

The SATA connector supplies the data connection for the SATA hard disk and is SATA 3.0 compatible.

Figure 14: SATA Connector SATA1, SATA2

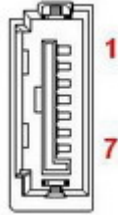

Table 22: Pin Assignment SATA1, SATA2

Pin	Signal	Note
1	GND	
2	TX+	
3	TX-	
4	GND	
5	RX-	
6	RX+	
7	GND	

Table 23: Signal Description

Signal	Description
RX+ / RX-	Host transmitter differential signal pair
TX+ / TX-	Host receiver differential signal pair

7.4. HDD Power Output Wafer (CN1)

Figure 15: HDD Power Output Wafer CN1



Table 24: Pin Assignment CN1

Pin	Signal	Note
1	+12V	
2	GND	
3	GND	PWR
4	+5V	PWR

7.5. USB Connectors (Internal) (CN8)

USB 2.0 Port 4 and 5 are supplied via the internal pin header (CN8) and / or the M.2 connector (CON1, See Section 7.).

Figure 16: USB 2.0 Pin Header CN8

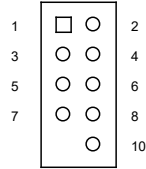

Table 25: Pin Assignment CN8

Pin	Signal	Note
1	+USBVCC	
2	+USBVCC	
3	USB_A-	
4	USB_B-	
5	USB_A+	
6	USB_B+	
7	GND	
8	GND	
9	KEY	
10	GND	

Table 26: Signal Description

Signal	Description
+USBVCC	5 V supply for external devices. 5V is supplied during power down to allow wakeup on USB device activity. Protected by active power switch 1 A fuse for each USB port.
USB_A-/+	Universal Serial Bus Differentials: Bus Data / Address / Command Bus.
USB_B-/+	Universal Serial Bus Differentials: Bus Data / Address / Command Bus.

7.6. Speaker Connector (CN10 & CN15)

The Speaker audio-out interface is available through the wafers CN10 and CN15. These outputs are shared with the audio output (Line-out) signals of the audio pin header CN9. With up to 100 dB Signal-to-Noise Ratio (SNR).

Figure 17: 3W Audio AMP Output Wafer CN10 (Left Channel), CN15 (Right Channel)

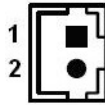

Table 27: Pin Assignment CN8

Pin	Signal	Note
1	Speaker+	
2	Speaker-	

7.7. Audio Connector (CN9)

The audio connector provides audio output (Line-Out), audio input (Line-In) and microphone (Mic-In) signals through the wafer CN9. The audio output signals are shared with those of the speaker connectors CN10 & CN15. The Signal-to-Noise Ratio (SNR) is up to 100dB.

Figure 18: Audio Input / Output Pin Header CN9

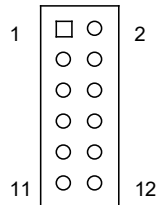

Table 28: Pin Assignment CN8

Pin	Signal	Note
1	MIC-In_L	
2	MIC-In_R	
3	MIC-In_JD#	
4	GND	
5	Line-In_L	
6	Line-In_R	
7	Line-In_JD#	
8	GND	
9	Line-Out_L	
10	Line-Out_R	

Pin	Signal	Note
11	Line-Out_JD#	
12	GND	

7.8. Front Panel Pin Header (FP1 & FP2)

Figure 19: Front Panel Pin Header FP1

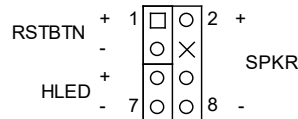

Table 29: Pin Assignment FP1

Pin	Signal	Note
1	Reset Button +	
2	Speaker +	
3	Reset Button -	
4	NC	
5	HDD LED +	
6	Internal Speaker -	
7	HDD LED -	
8	Speaker -	



Internal Buzzer is enabled when Pin6-8 is shorted.

Table 30: Signal Description

Signal	Description
Reset Button -/+	Reset Button. This 2-pin connector is for chassis mounted reset button for system reboot without turning off the system power.
HDD LED -/+	Hard Disk Drive Activity LED. This 2-pin connector is for HDD Activity LED. Connect the HDD Activity LED cable to this connector. The HDD LED lights up or flashes when data is read from or written to the HDD.
Internal Speaker - Speaker -/+	System warning speaker. The speaker allows user to hear beeps and warnings.

Figure 20: Front Panel Pin Header FP2

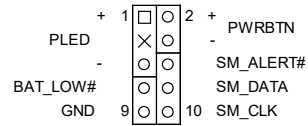

Table 31: Pin Assignment FP2

Pin	Signal	Note
1	Power LED +	
2	Power Button +	
3	NC	
4	Power Button -	
5	Power LED -	
6	SMB_ALERT#	
7	BATLOW#	
8	SMBus Data	
9	GND	
10	SMBus Clock	

Table 32: Signal Description

Signal	Description
Power LED -/+	System Power LED. The power LED lights up when users turn on the system power, and blinks when the system is in sleep mode.
Power Button -/+	The 2-pin connector is for the system power button. Pressing the power button turns the system on or puts the system in sleep or soft-off mode depending on the operating system settings. Pressing the power switch for more than four seconds while the system turns from ON to OFF.
SMB_ALERT#	System Management Bus Alert
SMBus Data	System Management Bus bidirectional data line
SMBus Clock	System Management Bus bidirectional clock line
BATLOW#	Battery low input. This signal may be driven low by external circuitry to signal that the system battery is low. It also can be used to signal some other external power management event.

7.9. Serial COM1 - COM2 Ports (CN6 & CN7)

Figure 21: Serial COM CN6, CN7

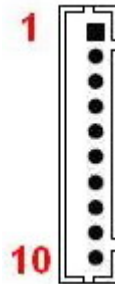

Table 33: Pin Assignment CN6, CN7

Pin	RS232 Signal	RS422 Signal	Half Duplex RS485 Signal	Full Duplex RS485 Signal	Note
1	DCD	TX-	DATA-	TX-	
2	DSR	N/A	N/A	N/A	
3	RXD	TX+	DATA+	TX+	
4	RTS	N/A	N/A	N/A	
5	TXD	RX+	N/A	RX+	
6	CTS	N/A	N/A	N/A	
7	DTR	RX-	N/A	RX-	
8	RI	N/A	N/A	N/A	
9	GND	GND	GND	GND	
10	+5V	+5V	+5V	+5V	



The COM1 and COM2 serial ports need to install an OS patch from ITE. The patch is only available for Windows and is not available Linux.

Table 34: Signal Description

Signal	Description
TXD	Transmitted Data, sends data to the communications link. The signal is set to the marking state (-12 V) on hardware reset when the transmitter is empty or when loop mode operation is initiated.
RXD	Received Data, receives data from the communications link.
DTR	Data Terminal Ready, indicates to the modem etc. that the on-board UART is ready to establish communication link.
DSR	Data Set Ready, indicates that the modem etc. is ready to establish a communications link.
RTS	Request To Send, indicates to the modem etc. that the on-board UART is ready to exchange data.
CTS	Clear To Send, indicates that the modem or data set is ready to exchange data.
DCD	Data Carrier Detect, indicates that the modem or data set has detected the data carrier.
RI	Ring Indicator, indicates that the modem has received a ringing signal from the telephone line.
TX+/-	Transmitted Data differential pair sends data to the communications link.

Signal	Description
RX+/-	Received Data differential pair receives data from the communications link.
GND	Power Supply GND signal

7.10. LVDS Flat Panel Connector (LVDS1)

The LVDS connector is based on 30-pole connector type JAE JS-1267-30(G1)NH.

Figure 22: LVDS Connector LVDS1



Table 35: Pin Assignment LVDS1

Pin	Signal	Note
1	TxoutA0-	
2	TxoutA0+	
3	TxoutA1-	
4	TxoutA1+	
5	TxoutA2-	
6	TxoutA2+	
7	GND	
8	TxclkA-	
9	TxclkA+	
10	TxoutA3-	
11	TxoutA3+	
12	TxoutB0-	
13	TxoutB0+	
14	GND	
15	TxoutB1-	

Pin	Signal	Note
16	TxoutB1+	
17	GND	
18	TxoutB2-	
19	TxoutB2+	
20	TxclkB-	
21	TxclkB+	
22	TxoutB3-	
23	TxoutB3+	
24	GND	
25	DDC_Data	
26	VDD_EN	
27	DDC_Clock	
28	+3.3V / +5V*	
29	+3.3V / +5V*	
30	+3.3V / +5V*	



* Panel Power can be selected by JP4.

Table 36: Signal Description

Signal	Description
TxoutA0..A3	LVDS A Channel data
TxclkA	LVDS A Channel clock
TxoutB0..B3	LVDS B Channel data
TxclkB	LVDS B Channel clock
VDD_EN	Output Display Enable
DDC_Data	DDC channel Data
DDC_Clock	DDC Channel Clock

7.11. LCD Panel Power Connector for LVDS1 (CN16)

Figure 23: LCD Panel Power Connector CN16

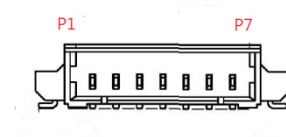

Table 37: Pin Assignment CN16

Pin	Signal	Note
1	BL_ADJ_PWM	
2	NC	
3	GND	
4	+5V / +12V*	
5	+5V / +12V*	
6	GND	
7	BL_EN**	



* Backlight Power can be selected by JP2



** BL_EN can be selected by JP4

Table 38: Signal Description

Signal	Description
BL_ADJ_PWM	Backlight Adjustment PWM (Pulse Width Modulation) signal,
BL_PWM	Backlight PWM (Pulse Width Modulation) signal
BL_EN	Backlight Enable signal

7.12. Digital Input / Output Wafer (CN5)

Figure 24: Digital Input / Output Wafer CN5

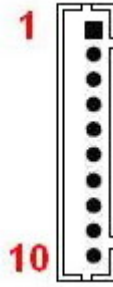

Table 39: Pin Assignment FP2

Pin	Signal	Note
1	+5V	
2	DI0	
3	DO0	
4	DI1	
5	DO1	
6	DI2	
7	DO2	
8	DI3	
9	DO3	
10	GND	

Table 40: Signal Description

Signal	Description
DI0..3	Digital Input signal
DO0..3	Digital Output signal

7.13. mPCIe Slot Connector (MPCIE1)

Full-sized Mini-PCI Express V1.2 socket (MPCIE1). Socket MPCIE1 supports mPCIe, USB 2.0 and SIM-card socket. The SIM-card socket makes it possible to use a 3G/4G-wireless modem in this mPCIe slot. The USB does support WAKE function.

Figure 25: mPCIe Slot Connector MPCIE1

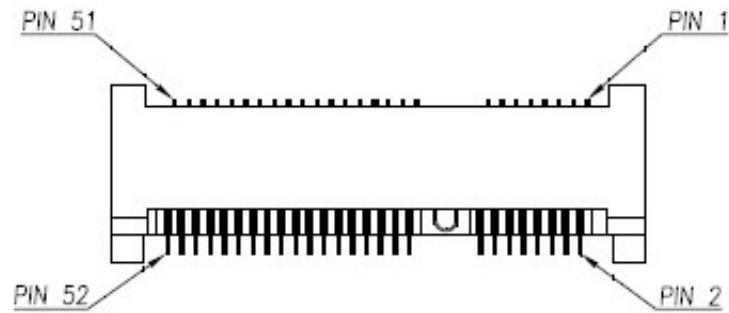

Table 41: Pin Assignment MPCIE1

Pin	Signal	Note
1	WAKE#	
2	+3.3VSB / +3.3V*	
3	Reserved	
4	Ground	
5	Reserved	
6	+1.5V	
7	CLKREQ#	
8	UIM_PWR**	
9	Ground	
10	UIM_DATA**	
11	REFCLK-	
12	UIM_CLK**	
13	REFCLK+	
14	UIM_RESET**	
15	Ground	
16	UIM_VPP**	
17	Reserved	
18	Ground	
19	Reserved	
20	W_Disable#	
21	Ground	
22	PERST#	
23	PERn*	
24	+3.3VSB / +3.3V*	
25	PERp*	

Pin	Signal	Note
26	Ground	
27	Ground	
28	+1.5V	
29	Ground	
30	SMB_CLK	
31	PETn*	
32	SMB_DATA	
33	PETp*	
34	Ground	
35	Ground	
36	USB_D-	
37	Ground	
38	USB_D+	
39	+3.3VSB / +3.3V*	
40	Ground	
41	+3.3VSB / +3.3V*	
42	LED_WWAN#	
43	Ground / NC*	
44	LED_WLAN#	
45	Reserved	
46	LED_WPAN#	
47	Reserved	
48	+1.5V	
49	Reserved	
50	Ground	
51	Reserved	
52	+3.3VSB / +3.3V*	



* These pins are used to configure mPCIe.



** These pins are connected to SIM1 directly.

7.14. NGFF M.2 Key B Slot Connector (CON1)

The 3.5"-SBC-SKL supports M.2 modules in format 2242 with Key B. The M.2 specification enables one SATA3.0 (6 Gb/s), one USB 2.0 and SIM-card socket to be exposed through the same slot. The SIM-card socket makes it possible to use a 3G/4G-wireless modem in this M.2 slot. The USB does support WAKE function.

Figure 26: NGFF M.2 Key B Slot Connector CON1

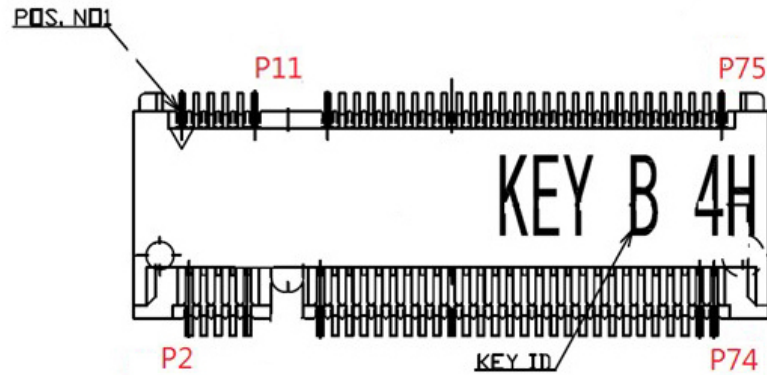

SATA M.2 requires the following BIOS depending on the class code options below.

M.2 SSD	Boot	Storage
SATA M.2 SSD	Supported	Supported

Table 42: Pin Assignment CON1

Pin	Signal	Note
1	CONFIG3	
2	+3.3V	
3	GND	
4	+3.3V	
5	GND	
6	FULL CARD PWR OFF	
7	USB-D+	
8	W DISABLE#1	
9	USB-D-	
10	GPIO9	
11	GND	
12	KEY B	
13	KEY B	
14	KEY B	
15	KEY B	
16	KEY B	
17	KEY B	
18	KEY B	
19	KEY B	

Pin	Signal	Note
20	GPIO5	
21	CONFIO	
22	GPIO6	
23	GPIO11	
24	GPIO7	
25	GPIO12	
26	GPIO10	
27	GND	
28	GPIO8	
29	PETn1/USB30TX-	
30	UIM RESET	
31	PETp1/USB30TX+	
32	UIM CLK	
33	GND	
34	UIM DATA	
35	PERn1/USB30RX+	
36	UIM PWR	
37	PERp1/USB30RX-	
38	DEVSLP	
39	GND	
40	GPIO0	
41	PETn0/SATAB+	
42	GPIO1	
43	PETp0/SATAB-	
44	GPIO2	
45	GND	
46	GPIO3	
47	PERn0/SATAA-	
48	GPIO4	
49	PERp0/SATAA+	
50	PERST	
51	GND	
52	CLKREQ	
53	REFCLKN	
54	PEWAKE	
55	REFCLKP	
56	MFG_DAT	
57	GND	
58	MFGCLK	
59	ANTCTL	
60	COEX	
61	ANTCTL	

Pin	Signal	Note
62	COEX	
63	ANTCTL	
64	COEX	
65	ANTCTL	
66	SIM DETECT	
67	PER1-	
68	SUSCLK	
69	CONFIG1	
70	+3.3V	
71	GND	
72	+3.3V	
73	GND	
74	+3.3V	
75	CONFIG2	

7.15. SIM Card Connector (CN4)

Figure 27: SIM Interface Wafer CN4

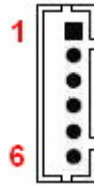

Table 43: Pin Assignment CN4

Pin	Signal	Description
1	UIM_PWR	Power +5V or +3.3V
2	UIM_DATA	Input or Output for serial data
3	UIM_RESET	Reset signal
4	UIM_VPP	Programming voltage input (optional)
5	UIM_CLK	Clock signal
6	GND	Ground

7.16. Switches and Jumpers

The product has several jumpers which must be properly configured to ensure correct operation.

Figure 28: Jumper Connector

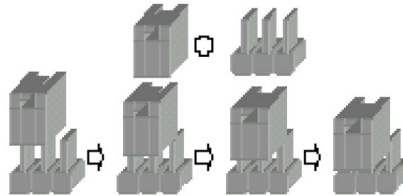

For a three-pin jumper (see Figure 28), the jumper setting is designated "1-2" when the jumper connects pins 1 and 2. The jumper setting is designated "2-3" when pins 2 and 3 are connected and so on. You will see that one of the lines surrounding a jumper pin is thick, which indicates pin No.1.

To move a jumper from one position to another, use needle-nose pliers or tweezers to pull the pin cap off the pins and move it to the desired position.

7.16.1. MPCIE1 Activity LED Pin Header (JP1)

Figure 29: MPCIE1 Activity LED Pin Header JP1

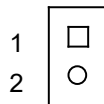

Table 44: Pin Assignment JP1

Pin	Signal	Note
1	LED+	
2	LED-	

7.16.2. Panel & Backlight Power Selection for LVDS1 (JP2)

Figure 30: Panel & Backlight Power Selection for LVDS1 (JP2)

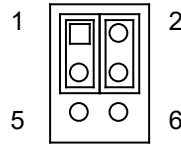

Table 45: Pin Assignment JP1

Jumper 1 Position		Description
Pin 1-3	Pin 3-5	
X	-	Backlight Power = +12V
-	X	Backlight Power = +5V
Jumper 2 Position		Description
Pin 2-4	Pin 4-6	
X	-	Panel Power = +3,3V
-	X	Panel Power = +5V

"X" = Jumper set (short) and "-" = jumper not set (open)

7.16.3. NGFF M.2 Activity LED Pin Header (JP3)

Figure 31: NGFF M.2 Activity LED Pin Header (JP3)

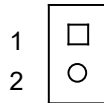

Table 46: Pin Assignment JP3

Pin	Signal	Note
1	LED+	
2	LED-	

7.16.4. Backlight Power Enable Selection for LVDS1 (JP4)

Figure 32: Backlight Power Enable Selection for LVDS1 (JP4)

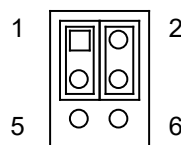

Table 47: Pin Assignment JP4

Jumper 1 Position		Description
Pin 1-3	Pin 3-5	
X	-	Backlight Enable Voltage = +3.3V
-	X	Backlight Enable Voltage = +5V
Jumper 2 Position		Description
Pin 2-4	Pin 4-6	
X	-	Active High
-	X	Active Low

"X" = Jumper set (short) and "-" = jumper not set (open)

7.16.5. AT / ATX Power Mode & NGFF mSATA / mPCIe Selection (JP6)

Figure 33: AT / ATX Power Mode & NGFF mSATA / mPCIe Selection (JP6)

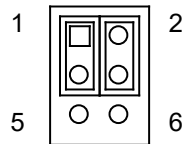

Table 48: Pin Assignment JP6

Jumper 1 Position		Description
Pin 1-3	Pin 3-5	
X	-	ATX Mode
-	X	AT Mode
Jumper 2 Position		Description
Pin 2-4	Pin 4-6	
X	-	NGFF Select mSATA
-	X	NGFF Select mPCIe

"X" = Jumper set (short) and "-" = jumper not set (open)

7.16.6. SIM Card and USB Power Selection (JP7)

Figure 34: SIM Card and USB Power Selection (JP7)

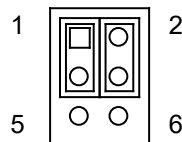

Table 49: Pin Assignment JP7

Jumper 1 Position		Description
Pin 1-3	Pin 3-5	
X	-	SIM Card to NGFF
-	X	SIM Card to mPCIe
Jumper 2 Position		Description
Pin 2-4	Pin 4-6	
X	-	S5 USB Power Support
-	X	S3 USB Power Support

"X" = Jumper set (short) and "-" = jumper not set (open)

7.16.7. Flash Descriptor Security Override Selection (JP8)

Figure 35: Flash Descriptor Security Override Selection (JP8)

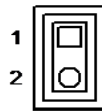

Table 50: Pin Assignment JP8

Jumper Position	Description
Pin 1-2	
X	Enable
-	Disabled

"X" = Jumper set (short) and "-" = jumper not set (open)

7.16.8. RTC Reset Selection (JP9)

The "RTC Reset" jumper (JP9) can be used to reset the Real Time Clock (RTC) and drain RTC well.

The jumper has one position: Pin 1-2 and not mounted (default position). More information on setting the "RTC Reset" jumper can be found in the following table.

Figure 36: RTC Reset Selection (JP9)

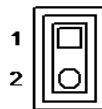

Table 51: Pin Assignment JP9

Jumper Position	Description
Pin 1-2	

Jumper Position	Description
Pin 1-2	
X	Enable Clear CMOS RTC content (board does not boot with the jumper in this position)
-	Disabled (default position)

"X" = Jumper set (short) and "-" = jumper not set (open)



Do not leave the jumper in position 1-2, otherwise if the power is disconnected, the battery will fully deplete within a few weeks.

7.16.9. Clear ME Register (JP10)

Figure 37: Clear ME Register (JP10)

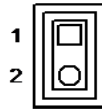

Table 52: Pin Assignment JP10

Jumper Position	Description
Pin 1-2	
X	Enable Clear ME
-	Disabled

"X" = Jumper set (short) and "-" = jumper not set (open)

8/ On-Board Connectors & Mating Connector Types

The Mating connectors / Cables are connectors or cable kits which are fitting the On-board connector.

The Kontron cable kits marked with "*" are included in the "3.5"-SBC-SKL Cable & Driver Kit".

Table 53: On-Board Connectors & Mating Connector Types

Connector	On-Board Connectors		Mating Connectors / Cables	
	Manufact.	Type No.	Manufact.	Type No.
Power Input (CN2)	Pinrex	733-97-04TBR1		0C5020000001580L
RTC Power Input (BAT1)	Pinrex	712-73-02TWR0		
CPU Fan (FAN1)	Foxconn	HF2704E-M1		
SATA (SATA1, SATA2)	Win Win	WATM-07ABN4A2B8UW4		0C5020000004240L
HDD Power Output (CN1)	Zi Hui	233-041N1T0112		0C5020000004240L
USB (CN8)	Pinrex	210-72-05GY22	Pinrex	0C502USB0201010L
Speaker (CN10, CN15)	Yimtex	503PW1*02STR 503PW1*02ST-1R		
Audio (CN9)	Pinrex	212-92-06GBE1		0C5020000002050L
Front Panel (FP1)	Pinrex	210-92-04GB01		
Front Panel (FP2)	Pinrex	210-92-05GB01		
COM (CN6, CN7)	Pinrex	712-73-10TWB0		0C5020000000910L
LVDS Flat Panel (LVDS1)	JAE	JS-1267-30(G1)NH		
LCD Power (CN16)	Zi Hui	W-125MRS-07		
DIO (CN5)	Pinrex	712-73-10TWB0		0C5020000002060L
mPCIe (MPCIE1)				
M.2 (CON1)	Yannis	M2S01-2B1R		
SIM (CN4)	Pinrex	712-73-06TWB0		
MPCIe LED (JP1)	Pinrex	210-91-02GB01		
M.2 LED (JP3)	Pinrex	210-91-02GB01		



Please note that standard connectors like DP, mPCIe, Audio Jack, Ethernet and USB are not included in the list.

9/ BIOS

9.1. Starting the uEFI BIOS

The 3.5"-SBC-SKL is provided with a Kontron-customized, pre-installed and configured version of AMI Aptio® V uEFI BIOS. AMI BIOS firmware is based on the Unified Extensible Firmware Interface (UEFI) specification and the Intel® Platform Innovation Framework for EFI. This uEFI BIOS provides a variety of new and enhanced functions specifically tailored to the hardware features of the 3.5"-SBC-SKL.

The uEFI BIOS comes with a setup program that provides quick and easy access to the individual function settings for control or modification of the uEFI BIOS configuration. The setup program allows the accessing of various menus that provide functions or access to sub-menus with more specific functions of their own.

To start the uEFI BIOS setup program, follow the steps below:

1. Power on the board.
2. Wait until the first characters appear on the screen (POST messages or splash screen).
3. Press the key.
4. If the uEFI BIOS is password-protected, a request for password will appear. Enter either the User Password or the Supervisor Password (see Security menu), press <RETURN>, and proceed with step 5.
5. A setup menu will appear.

The 3.5"-SBC-SKL uEFI BIOS setup program uses a hot key-based navigation system. A hot key legend bar is located on the bottom of the setup screens.

The following table provides information concerning the usage of these hot keys.

Table 54: Font Size Table

Hotkeys	Description
<F1>	The <F1> key invokes the General Help window.
<->	The <Minus> key selects the next lower value within a field.
<+>	The <Plus> key selects the next higher value within a field.
<F2>	The <F2> key loads the previous values.
<F3>	The <F3> key loads the standard default values.
<F4>	The <F4> key saves the current settings and exit the uEFI BIOS setup.
<→> or <←>	The <Left/Right> arrows selects major setup menus on the menu bar. For example: Main, Advanced, Security, etc.
<↑> or <↓>	The <Up/Down> arrows selects fields in the current menu. For example: A setup function or a sub-screen.
<ESC>	The <ESC> key exits a major setup menu and enter the Exit setup menu. Pressing the <ESC> key in a sub-menu displays the next higher menu level.
<RERURN>	The <RETURN> key executes a command or select a submenu.

9.2. Setup Menus

The Setup utility features shows six menus in the selection bar at the top of the screen:

- ▶ Main
- ▶ Advanced
- ▶ Power
- ▶ Boot
- ▶ Security
- ▶ Save & Exit

The Setup menus are selected via the left and right arrow keys. The currently active menu and the currently active uEFI BIOS Setup item are highlighted in white. Each Setup menu provides two main frames. The left frame displays all available functions. Functions that can be configured are displayed in blue. Functions displayed in gray provide information about the status or the operational configuration. The right frame displays an Item Specific Help window providing an explanation of the respective function.

9.2.1. Main Setup Menu

Upon entering the uEFI BIOS Setup program, the Main Setup menu is displayed. This screen lists the Main Setup menu sub-screens and provides basic system information. Additionally functions for setting the system time and date are offered.

Table 55: Main Setup Menu Sub-Screens and Functions

Function	Description
BIOS Information	Read only field. Displays information about the system BIOS
Memory Information	Read only field. Displays information about total memory
ME Information	Read only field. Displays information about Intel Management Engine (ME) version
TXE Information	Read only field. Displays information about TXE information
Firmware Information	Code version and firmware information
System Date	Set System Date
System Time	Set System Time

Figure 38: BIOS Main Menu Screen System Data and Time

BIOS SETUP UTILITY					
Main	Advanced	Power	Boot	Security	Save & Exit
Product Information					
Product Name		3.5"-SBC-SKL-6600U			
BIOS Version		R0.05 (x64)			
BIOS Build Date		12/15/2016			
ME FW Version		11.0.0.1202			
CPU Information					
Intel® Core™ i7-6600U CPU @ 2.60GHz					
Microcode Revision		7C			
Processor Cores		2		→ ←: Select Screen	
Memory Information					
Total Size		4069 MB (DDR4)		↑ ↓: Select Item	
Frequency		2133 MHz		Enter: Select	
System Date		[Fri 01/01/2016]		+/-: Change Opt.	
System Time		[00:16:42]		F1: General Help	
Access Level		Administrator		F2: Previous Values	
				F3: Optimized Defaults	
				F4: Save & Exit	
				ESC: Exit	
Version 2.17.1255. Copyright (C) 2016, American Megatrends, Inc.					

Feature	Option	Description
System Date	[dd/mm/yyyy]	Set the Date. Use Tab to switch between Data elements.
System Time	[hh:mm:ss]	Set the Time. Use Tab to switch between Time elements.

9.2.2. Advanced Setup Menu

The Advanced setup menu provides sub-screens and functions for advanced configurations. The following sub-screen functions are included in the menu:

- ▶ LAN & Audio Configuration
- ▶ Display Configuration
- ▶ Super IO Configuration
- ▶ CPU Chipset Configuration
- ▶ SATA Configuration
- ▶ USB Configuration
- ▶ DIO Configuration
- ▶ H/W Monitor

NOTICE

Setting items on this screen to incorrect values may cause the system to malfunction.

Figure 39: BIOS Advanced Menu

BIOS SETUP UTILITY					
Main	Advanced	Power	Boot	Security	Save & Exit
Onboard LAN1 Controller		[Enabled]			
Onboard LAN1 Boot		[Disabled]			
Onboard LAN2 Controller		[Enabled]			
Onboard LAN2 Boot		[Disabled]			
Audio Controller		[Enabled]			
> Display Configuration				→ ←: Select Screen	
> Super IO Configuration				↑ ↓: Select Item	
> CPU Chipset Configuration				Enter: Select	
> SATA Configuration				+/-: Change Opt.	
> USB Configuration				F1: General Help	
> TPM Configuration				F2: Previous Values	
> DIO Configuration				F3: Optimized Defaults	
> H/W Monitor				F4: Save & Exit	
				ESC: Exit	
Version 2.17.1255. Copyright (C) 2016, American Megatrends, Inc.					

Feature	Option	Description
Onboard LAN1 Controller	[Disabled], [Enabled]	Select whether to enable or disable Onboard LAN1 Controller.
Onboard LAN1 Boot	[Disabled], [Enabled]	Select whether to enable or disable load onboard PXE (Preboot Execution Environment).
Onboard LAN2 Controller	[Disabled], [Enabled]	Select whether to enable or disable Onboard LAN2 Controller.
Onboard LAN2 Boot	[Disabled], [Enabled]	Select whether to enable or disable load onboard PXE (Preboot Execution Environment).
Audio Controller	[Disabled], [Enabled]	Select whether to enable or disable Audio Controller.

Figure 40: BIOS Advanced Menu - Display Configuration

BIOS SETUP UTILITY					
Main	Advanced	Power	Boot	Security	Save & Exit
Display Information					
Primary Display		[Auto]			
UWA Frame Buffer Size		[256MB]			
DVMT Pre-Allocated		[64M]		→ ←: Select Screen	
DVMT Total Gfx Mem		[256MB]		↑ ↓: Select Item	
Primary IGFX Boot Display		[VBIOS Default]		Enter: Select	
Active LFP		[Disabled]		+/-: Change Opt.	
LVDS Panel Type*		[1366x768 1CH]		F1: General Help	
LVDS Panel Color Depth*		[18Bit]		F2: Previous Values	
PWM Backlight Control*		[By External]		F3: Optimized Defaults	
LVDS Backlight Control - PWM*		127		F4: Save & Exit	
				ESC: Exit	
Version 2.17.1255. Copyright (C) 2016, American Megatrends, Inc.					

* These items appear only when enabling Active LFP.

Feature	Option	Description
Primary Display	[Auto], [IGFX], [PCIE]	Select which graphic controller to be used as the primary display device.
UWA Frame Buffer Size	[128MB], [256MB], [512MB]	Select the Aperture Size. Note: Above 4GB MMIO BIOS assignment is automatically enabled when selecting 2048MB aperture. To use this feature, please disable CSM Support.
DVMT Pre-Allocated	[32M], [64M], [96M], [128M], [160M], [192M], [224M], [256M], [288M], [320M], [352M], [384M], [416M], [448M], [480M], [512M], [1024M]	Select DVMT 5.0 Pre-Allocated (Fixed) Graphics Memory size used by the Internal Graphics Device.
DVMT Total Gfx Mem	[128M], [256M], [MAX]	Select DVMT 5.0 Total Graphic Memory size used by the Internal Graphics Device.
Primary IGFX Boot Display	[VBIOS Default], [DP], [HDMI], [LVDS]	Select the Video Device which will be activated during POST. This has no effect if external graphics present. Secondary boot display selection will appear based on your selection. DOS modes will be supported only on primary display.
Active LFP	[Disabled], [Enabled]	Select the Active LVDS Configuration. [Disabled]: VBIOS does not enable LVDS. [Enabled]: VBIOS will enable LVDS.
LVDS Panel Type	[1024x768 1CH], [1280x1024 2CH], [1366x768 1CH],	Select the appropriate setup item for LVDS panel.

Feature	Option	Description
	[1366x768 2CH], [1440x900 2CH], [1600x1200 2CH], [1920x1080 2CH]	
LVDS Panel Color Depth	[18Bit], [24Bit]	Select the appropriate setup item for LVDS panel color depth.
PWM Backlight Control	[By External], [By Internal]	Select the PWM backlight controller. [By External]: Control by external HW circuit. [By Internal]: Control by LBKLT_CTL on the Intel Chipset.

Figure 41: BIOS Advanced Menu - Super IO Configuration

BIOS SETUP UTILITY					
Main	Advanced	Power	Boot	Security	Save & Exit
Super IO Configuration					
> Serial Port 1 Configuration > Serial Port 2 Configuration				→ ←: Select Screen ↑ ↓: Select Item Enter: Select +/-: Change Opt. F1: General Help F2: Previous Values F3: Optimized Defaults F4: Save & Exit ESC: Exit	
Version 2.17.1255. Copyright (C) 2016, American Megatrends, Inc.					

Figure 42: BIOS Advanced Menu - Super IO Configuration - Serial Port 1 Configuration

BIOS SETUP UTILITY					
Main	Advanced	Power	Boot	Security	Save & Exit
Serial Port 1 Configuration					
Serial Port		[Enabled]			
Device Settings		IO=3F8h; IRQ=4;			
Change Setting		[Auto]			
Serial Port 1 Type		[RS232]			
RS485 Deplx Mode*		[Half Duplex]			
RS485 Auto Flow Control*		[Disabled]			
				→ ←: Select Screen ↑ ↓: Select Item Enter: Select +/-: Change Opt. F1: General Help F2: Previous Values F3: Optimized Defaults F4: Save & Exit ESC: Exit	
Version 2.17.1255. Copyright (C) 2016, American Megatrends, Inc.					

* These items appear only when selecting RS485 for the Serial Port 1 Type.

Feature	Option	Description
Serial Port	[Disabled], [Enabled]	Select whether to enable or disable Serial Port (COM).
Change Settings	[Auto], [IO=3F8h; IRQ=4;], [IO=3F8h; IRQ=3, 4, 5, 6, 7, 9, 10, 11, 12;], [IO=2F8h; IRQ=3, 4, 5, 6, 7, 9, 10, 11, 12;], [IO=3E8h; IRQ=3, 4, 5, 6, 7, 9, 10, 11, 12;], [IO=2E8h; IRQ=3, 4, 5, 6, 7, 9, 10, 11, 12;]	Select an optional setting for Super IO device.

Feature	Option	Description
Serial Port 1 Type	[RS232], [RS422], [RS485]	Select an appropriate type for Serial Port 1.
RS485 Duplex Mode	[Half Duplex], [Full Duplex]	Select an appropriate RS485 Duplex Mode.
RS485 Auto Flow Control	[Disabled], [Enabled]	Select whether to enable or disable RS485 Auto Flow Control

Figure 43: BIOS Advanced Menu - Super IO Configuration - Serial Port 2 Configuration

BIOS SETUP UTILITY					
Main	Advanced	Power	Boot	Security	Save & Exit
Serial Port 2 Configuration					
Serial Port		[Enabled]		→ ←: Select Screen	
Device Settings		IO=2F8h; IRQ=3;		↑ ↓: Select Item	
Change Setting		[Auto]		Enter: Select	
Serial Port 2 Type		[RS232]		+/-: Change Opt.	
RS485 Deplx Mode*		[Half Duplex]		F1: General Help	
RS485 Auto Flow Control*		[Disabled]		F2: Previous Values	
				F3: Optimized Defaults	
				F4: Save & Exit	
				ESC: Exit	
Version 2.17.1255. Copyright (C) 2016, American Megatrends, Inc.					

* These items appear only when selecting RS485 for the Serial Port 2 Type.

Feature	Option	Description
Serial Port	[Disabled], [Enabled]	Select whether to enable or disable Serial Port (COM).
Change Settings	[Auto], [IO=2F8h; IRQ=3;], [IO=3F8h; IRQ=3, 4, 5, 6, 7, 9, 10, 11, 12;], [IO=2F8h; IRQ=3, 4, 5, 6, 7, 9, 10, 11, 12;], [IO=3E8h; IRQ=3, 4, 5, 6, 7, 9, 10, 11, 12;], [IO=2E8h; IRQ=3, 4, 5, 6, 7, 9, 10, 11, 12;]	Select an optional setting for Super IO device.
Serial Port 2 Type	[RS232], [RS422], [RS485]	Select an appropriate type for Serial Port 2.
RS485 Duplex Mode	[Half Duplex], [Full Duplex]	Select an appropriate RS485 Duplex Mode.
RS485 Auto Flow Control	[Disabled], [Enabled]	Select whether to enable or disable RS485 Auto Flow Control

Figure 44: BIOS Advanced Menu - CPU Chipset Configuration

BIOS SETUP UTILITY					
Main	Advanced	Power	Boot	Security	Save & Exit
CPU Chipset Configuration					
EIST		[Enabled]		→ ←: Select Screen	
Hyper-threading		[Enabled]		↑ ↓: Select Item	
VT-d		[Enabled]		Enter: Select	
Active Processor Cores		[All]		+/-: Change Opt.	
Intel (VMX) Virtualization Technology		[Disabled]		F1: General Help	
				F2: Previous Values	
				F3: Optimized Defaults	
				F4: Save & Exit	
				ESC: Exit	
Version 2.17.1255. Copyright (C) 2016, American Megatrends, Inc.					

Feature	Option	Description
EIST	[Disabled], [Enabled]	Select whether to enable or disable Enhanced Intel SpeedStep Technology.
Hyper-threading	[Disabled], [Enabled]	Select whether to enable or disable Hyper-threading technology. [Enabled] for Windows XP and Linux (OS optimized for Hyper-Threading Technology). [Disabled] for other OS (OS not optimized for Hyper-Threading Technology).
VT-d	[Disabled], [Enabled]	Select whether to enable or disable VT-d capability.
Active Processor Cores	[All], [1]	Select the number of cores to enable in each processor package.
Intel (VMX) Virtualization Technology	[Disabled], [Enabled]	Select whether to enable or disable Intel (VMX) Virtualization Technology. A VMM can utilize the additional hardware capabilities provided by Vanderpool Technology when selecting [Enabled].

Figure 45: BIOS Advanced Menu - SATA Configuration

BIOS SETUP UTILITY					
Main	Advanced	Power	Boot	Security	Save & Exit
SATA Configuration					
SATA Controller(s)		[Enabled]		→ ←: Select Screen ↑ ↓: Select Item Enter: Select +/-: Change Opt. F1: General Help F2: Previous Values F3: Optimized Defaults F4: Save & Exit ESC: Exit	
SATA Mode Selection		[AHCI]			
Serial ATA Port 1		Empty			
Port 1		[Enabled]			
Serial ATA Port 2		Empty			
Port 2		[Enabled]			
M.2 SATA Port 1		Empty			
Port 1		[Enabled]			
Version 2.17.1255. Copyright (C) 2016, American Megatrends, Inc.					

Feature	Option	Description
SATA Controller(s)	[Enabled], [Disabled]	Select whether to enable or disable SATA Device.
SATA Mode Selection	[AHCI], [Intel RST Premium]	Determine how SATA controller(s) operate.
Port 1, 2	[Disabled], [Enabled]	Select whether to enable or disable SATA Port 1, 2 or M.2 SATA Port 1.

Figure 46: BIOS Advanced Menu - USB Configuration

BIOS SETUP UTILITY					
Main	Advanced	Power	Boot	Security	Save & Exit
USB Configuration					
USB Devices: 1 Keyboard, 1 Mouse				→ ←: Select Screen ↑ ↓: Select Item Enter: Select	
Legacy USB Support		[Enabled]		+/-: Change Opt.	
XHCI Hand-off		[Enabled]		F1: General Help	
USB Mass Storage Driver Support		[Enabled]		F2: Previous Values	
				F3: Optimized Defaults	
				F4: Save & Exit	
				ESC: Exit	
Version 2.17.1255. Copyright (C) 2016, American Megatrends, Inc.					

Feature	Option	Description
Legacy USB Support	[Enabled], [Disabled]	Select whether to enable or disable Legacy USB support. AUTO option disables legacy support if no USB devices are connected.
XHCI Hand-off	[Enabled], [Disabled]	Select whether to enable or disable XHCI Hand-off function. This is a workaround for OSeS without XHCI hand-off support. The XHCI ownership change should be claimed by XHCI driver.
USB Mass Storage Driver Support	[Disabled], [Enabled]	Select whether to enable or disable USB Mass Storage Driver Support.

Figure 47: BIOS Advanced Menu - DIO Configuration

BIOS SETUP UTILITY							
Main	Advanced	Power	Boot	Security	Save & Exit		
DIO Configuration							
User Configuration		[Disabled]					
DO_1*		[Output Low]					
DO_2*		[Output Low]					
DO_3*		[Output Low]					
DO_4*		[Output Low]					
DI_1		1		→ ←: Select Screen ↑ ↓: Select Item Enter: Select +/-: Change Opt. F1: General Help F2: Previous Values F3: Optimized Defaults F4: Save & Exit ESC: Exit			
DI_2		1					
DI_3		1					
DI_4		1					
DO_1		0					
DO_2		0					
DO_3		0					
DO_4		0					
Version 2.17.1255. Copyright (C) 2016, American Megatrends, Inc.							

* These items appear only when enabling User Configuration.

Feature	Option	Description
User Configuration	[Enabled], [Disabled]	Select whether or not to allow user to set the DO pin output value.
DO_1..4	[Output Low], [Output High]	Set up the DO pin output value.

Figure 48: BIOS Advanced Menu - H/W Monitor

BIOS SETUP UTILITY					
Main	Advanced	Power	Boot	Security	Save & Exit
PC Health Status					
> Smart FAN Configuration					
CPU Temperature		: +60 C			
Memory Temperature		: +54 C			
System Temperature		: +51 C			
CPU Fan Speed		: N/A		→ ←: Select Screen	
+V CORE		: +0.904 V		↑ ↓: Select Item	
+VIN		: +18.240 V		Enter: Select	
+3VCC		: +3.312 V		+/-: Change Opt.	
+3VSB		: +3.344 V		F1: General Help	
+VBAT		: +3.120 V		F2: Previous Values	
+5VA		: +5.064 V		F3: Optimized Defaults	
+3VA		: +3.280 V		F4: Save & Exit	
				ESC: Exit	
Version 2.17.1255. Copyright (C) 2016, American Megatrends, Inc.					

BIOS SETUP UTILITY					
Main	Advanced	Power	Boot	Security	Save & Exit
Smart FAN Configuration					
CPU FAN Setting		[Manual]		→ ←: Select Screen	
Manual Duty		255		↑ ↓: Select Item	
				Enter: Select	
				+/-: Change Opt.	
				F1: General Help	
				F2: Previous Values	
				F3: Optimized Defaults	
				F4: Save & Exit	
				ESC: Exit	
Version 2.17.1255. Copyright (C) 2016, American Megatrends, Inc.					

Feature	Option	Description
CPU FAN Setting	[Manual], [Smart]	Switch the CPU FAN control mode.

9.2.3. Power Setup Menu

The Power setup menu provides functions and a sub-screen for power configurations. The following sub-screen function is included in the menu:

- ▶ WatchDog Timer Configuration

Figure 49: BIOS Power Setup Menu

BIOS SETUP UTILITY					
Main	Advanced	Power	Boot	Security	Save & Exit
Power Configuration					
ACPI Sleep State		[S3 (Suspend to RAM)]			
Restore AC Power Loss		[Power Off]			
Power Saving Mode		[Disabled]			
Resume Event Control					
Resume By LAN Device		[Disabled]			
Resume By PCI-E Device		[Disabled]			
Resume By Ring Device		[Disabled]			
Resume By RTC Alarm		[Disabled]			
> WatchDog Timer Configuration					
				→ ←: Select Screen	
				↑ ↓: Select Item	
				Enter: Select	
				+/-: Change Opt.	
				F1: General Help	
				F2: Previous Values	
				F3: Optimized Defaults	
				F4: Save & Exit	
				ESC: Exit	
Version 2.17.1255. Copyright (C) 2016, American Megatrends, Inc.					

Feature	Option	Description
Restore AC Power Loss	[Power Off], [Power On], [Last State]	Control whether the system will stay on after AC power is removed and then restored. Select [Power Off] if you want the system to remain off after power restored. Select [Power On] if you use a power strip to turn the system on.
Power Saving Mode	[Disabled], [EUP Enabled], [DeepSx Enabled]	Select whether to enable Power Saving Mode. [EUP Enabled]: The system will enter to EUP Power Saving Mode during power off. [DeepSx Enabled]: The system will enter to DeepSx Power Saving Mode during S3/S4/S5 power off. [Disabled]: Disables function of all Power Saving Mode.
Resume By LAN Device	[Enabled], [Disabled]	Select whether to enable or disable Wake from LAN Device.
Resume By PCI-E Device	[Disabled], [Enabled]	Select whether to enable or disable Wake from PCI-E Device.
Resume By Ring Device	[Disabled], [Enabled]	Select whether to enable or disable Wake from Ring Device.
Resume By RTC Alarm	[Disabled], [Enabled]	Select whether to enable or disable Wake Up on Alarm, to turn on your system on a special day of the month.

Figure 50: BIOS Power Setup Menu - WatchDog Timer Configuration

BIOS SETUP UTILITY					
Main	Advanced	Power	Boot	Security	Save & Exit
WatchDog Timer Configuration					
WDT Function		[Disabled]		→ ←: Select Screen ↑ ↓: Select Item Enter: Select +/-: Change Opt. F1: General Help F2: Previous Values F3: Optimized Defaults F4: Save & Exit ESC: Exit	
Version 2.17.1255. Copyright (C) 2016, American Megatrends, Inc.					

Feature	Option	Description
WDT Function	[Disabled], [Enabled]	Select whether to enable or disable WatchDog Timer function.

9.2.4. Boot Setup Menu

The boot setup menu lists the for boot device priority order, that is generated dynamically.

Figure 51: BIOS Boot Setup Menu

BIOS SETUP UTILITY					
Main	Advanced	Power	Boot	Security	Save & Exit
Boot Configuration					
Full Screen LOGO Display		[Disabled]			
Setup Prompt Timeout		1		→ ←: Select Screen	
Bootup NumLock State		[On]		↑ ↓: Select Item	
CSM Support		[Enabled]		Enter: Select	
Boot Option Filter		[Legacy Only]		+/-: Change Opt.	
Boot Option Priorities				F1: General Help	
				F2: Previous Values	
				F3: Optimized Defaults	
				F4: Save & Exit	
				ESC: Exit	
Version 2.17.1255. Copyright (C) 2016, American Megatrends, Inc.					

Feature	Option	Description
Full Screen LOGO Display	[Disabled], [Enabled]	Select whether to enable or disable to display logo screen.
Bootup NumLock State	[On], [Off]	Select the state of the NumLock feature of the keyboard after Startup. [On]: The keys on the keypad will act as numeric keys. [Off]: The keys on the keypad will act as cursor keys.
CSM Support	[Enabled], [Disabled]	Select whether to enable or disable CSM support.
Boot Option Filter	[UEFI and Legacy], [Legacy only], [UEFI only]	Control Legacy / UEFI ROMs priority.

9.2.5. Security Setup Menu

The Security setup menu provides information about the passwords and functions for specifying the security settings. The passwords are case-sensitive. The 3.5"-SBC-SKL provides no factory-set passwords.

NOTICE

If there is already a password installed, the system asks for this first. To clear a password, simply enter nothing and acknowledge by pressing <RETURN>. To set a password, enter it twice and acknowledge by pressing <RETURN>.

Figure 52: BIOS Boot Setup Menu

BIOS SETUP UTILITY					
Main	Advanced	Power	Boot	Security	Save & Exit
Password Description					
If ONLY the Administrator's password is set, then this only limits access to Setup and is only asked for when entering Setup				→ ←: Select Screen	
If ONLY the User's password is set, then this is a power on password and must be entered to boot or enter Setup. In Setup the User will have Administrator rights					
The password length must be in the following range:					
Minimum Length		3		↑ ↓: Select Item	
Maximum length		20		Enter: Select	
Administrator Password				+/-: Change Opt.	
User Password				F1: General Help	
				F2: Previous Values	
				F3: Optimized Defaults	
				F4: Save & Exit	
				ESC: Exit	
Version 2.17.1255. Copyright (C) 2016, American Megatrends, Inc.					

Feature	Description
Administrator Password	Set administrator password
User Password	Set user password



If only the administrator's password is set, then only access to setup is limited. The password is only entered when entering setup.

If only the user's password is set, then the password is a power on password and must be entered to boot or enter setup. Within the setup menu the user has administrator rights.

Password length requirements are maximum 20 characters and minimum 3 characters.

9.2.5.1. Remember the password

It is highly recommended to keep a record of all passwords in a safe place. Forgotten passwords results in being locked out of the system.

If the system cannot be booted because the User Password or the Supervisor Password are not know, contact Kontron Support for further assistance.



HDD security passwords cannot be cleared using the above method.

9.2.6. Save & Exit Setup Menu

The exit setup menu provides functions for handling changes made to the UEFI BIOS settings and the exiting of the setup program.

Figure 53: BIOS Boot Setup Menu

BIOS SETUP UTILITY					
Main	Advanced	Power	Boot	Security	Save & Exit
Save Changes and Reset					
Discard Changes and Reset					
Save Options				→ ←: Select Screen	
Save Changes				↑ ↓: Select Item	
Discard Changes				Enter: Select	
Restore Defaults				+/-: Change Opt.	
				F1: General Help	
				F2: Previous Values	
				F3: Optimized Defaults	
				F4: Save & Exit	
				ESC: Exit	
Version 2.17.1255. Copyright (C) 2016, American Megatrends, Inc.					

Feature	Description
Save Changes and Exit	Exit system setup after saving the changes. Once you are finished making your selections, choose this option from the Exit menu to ensure the values you selected are saved to the CMOS RAM. The CMOS RAM is sustained by an onboard backup battery and stays on even when the PC is turned off. When you select this option, a confirmation window appears. Select [Yes] to save changes and exit.
Discard Changes and Exit	Exit system setup without saving any changes. Select this option only if you do not want to save the changes that you made to the Setup program. If you made changes to fields other than system date, system time, and password, the BIOS asks for a confirmation before exiting.
Save Changes	Save changes done so far to any of the setup values. This option allows you to save the selections you made. After selecting this option, a confirmation appears. Select [Yes] to save any changes.
Discard Changes	Discards changes done so far to any of the setup values. This option allows you to discard the selections you made and restore the previously saved values. After selecting this option, a confirmation appears. Select [Yes] to discard any changes and load the previously saved values.
Restore Defaults	Restore Default values for all the setup values. This option allows you to load optimal default values for each of the parameters on the Setup menus, which will provide the best performance settings for your system. The F9 key can be used for this operation.



About Kontron

Kontron, a global leader in embedded computing technology (ECT), offers a combined portfolio of secure hardware, middleware and services for Internet of Things (IoT) and Industry 4.0 applications. With its standard products and tailor-made solutions based on highly reliable state-of-the-art embedded technologies, Kontron provides secure and innovative applications for a variety of industries. As a result, customers benefit from accelerated time-to-market, reduced total cost of ownership, product longevity and the best fully integrated applications overall. Kontron is a listed company. Its shares are traded in the Prime Standard segment of the Frankfurt Stock Exchange and on other exchanges under the symbol "KBC". For more information, please visit: www.kontron.com

GLOBAL
HEADQUARTERS

Kontron Europe GmbH

Gutenbergstraße 2
85737 Ismaning
Germany
Tel.: + 49 821 4086-0
Fax: + 49 821 4086-111
info@kontron.com