

» Kontron User's Guide «



CB 752

User's Guide (Version 1.01)
0-0096-4743

This page is intentionally left blank.

1. Table of Contents

1. Table of Contents	1
1.1. Table of Figures.....	2
2. Introduction	4
2.1. Symbols used in this Manual.....	5
3. Important Instructions	6
3.1. Warranty Note	6
3.2. Exclusion of Accident Liability Obligation.....	6
3.3. Liability Limitation / Exemption from the Warranty Obligation	6
4. Safety Instructions	7
4.1. Electrostatic Discharge (ESD)	7
4.1.1. Grounding Methods.....	7
4.2. Instructions for the Lithium Battery.....	7
4.3. FCC Statement	8
4.4. Electromagnetic Compatibility (EU)	8
5. Scope of Delivery	9
5.1. Type Label and Product Identification	9
6. Product Description	10
6.1. Front View.....	11
6.1.1. DC IN – Direct Current Connector	11
6.1.2. Controls and Indicators.....	12
6.1.3. External Interfaces of the SBC Board at the Front Side	13
6.1.4. Optional Interfaces on the Front Side	14
6.2. Rear Side	16
6.2.1. Audio (LINE IN, LINE OUT and MIC IN).....	16
6.2.2. USB Ports.....	16
6.2.3. WiFi /WLAN (Option)	17
6.2.4. CF Slot Access Cover	17
6.3. Storage Media	17
6.4. Chassis with cooling Fins	18
6.5. Bottom Side	19
6.6. DC Power Cord	20
6.7. AC/DC-Adapter (Option).....	20
7. Assembly, Disassembly	21
7.1. Handling internal Components	21
7.1.1. Inserting and Removing the CF card	22
8. Starting Up	23
8.1. Connecting to DC or AC Main Power Supply	23
8.1.1. Connecting the CB 752 Platform to a DC Main Power Supply.....	23
8.1.2. Connecting the CB 752 Platform to an AC Main Power Supply using the AC/DC Adapter	23
8.2. Operating Systems and Hardware Component Drivers	25
9. Installing the CB 752 Platform	26
9.1. CB 752 Platform - Desktop.....	26

9.2. Mounting using the Brackets.....	27
10. Maintenance and Prevention.....	28
10.1. Replacing the Lithium Battery	28
10.2. Protection against Overheating	29
11. Technical Data.....	30
11.1. Electrical Specifications	31
11.2. Mechanical Specifications.....	31
11.2.1. CB 752 Desktop Dimensions.....	31
11.2.2. Dimensions for Wall and Table Mounting	33
11.3. Environmental Specifications	35
11.4. EC Directives and Standards	36
12. Standard Ports – Pin Assignment.....	37
12.1.1. DC IN Connector	37
12.1.2. Serial Port COM1, COM2 and COM3 (RS232).....	37
12.1.3. Serial Port COM2 (RS422/RS485) configured as RS422 (4-channel mode).....	38
12.1.4. Serial Port COM2 (RS422/RS485) configured as RS485 (4-wire mode), full duplex (bus master).....	38
12.1.5. Serial Port COM2 (RS422/RS485) configured as RS485 (2-wire mode), half duplex	39
12.1.6. VGA Port	39
12.1.7. CAN Bus Connector	40
12.1.8. USB Port.....	40
13. Technical Support.....	41
13.1. Returning Defective Merchandise	41

1.1. Table of Figures

Fig. 1: Front view	9
Fig. 2: Rear view	9
Fig. 3: Bottom view	10
Fig. 4: Right view	10
Fig. 5: Front view	10
Fig. 6: Left view	10
Fig. 7: Top view.....	10
Fig. 8: Rear view	10
Fig. 9: CB 752 – Front view.....	11
Fig. 10: CB 752 –Controls and Indicators	12
Fig. 11: External Interfaces of the integrated SBC.....	13
Fig. 12: CB 752 rear side with one (of two possible) WiFi antenna connector.....	16
Fig. 13: Covered USB port for system configuration with equipped COM3 port.....	16
Fig. 14: WLAN (WiFi) Antenna.....	17
Fig. 15: Detail of the rear side with the CF slot access cover removed.....	17
Fig. 16: Right side of the chassis	18

Fig. 17: Top side of the chassis	18
Fig. 18: Left side of the chassis.....	18
Fig. 19: Bottom side.....	19
Fig. 20: DC power cord	20
Fig. 21: AC/DC adapter	20
Fig. 22: AC power cord	20
Fig. 23: CB 752 with mounting brackets installed.....	27
Fig. 24: Detail: Hanging holes.....	27
Fig. 25: Left mounting bracket (optional)	27
Fig. 26: Right mounting bracket (optional)	27
Fig. 27: Rear side detail without CF access cover	28
Fig. 28: Dimensions in the front view (desktop).....	31
Fig. 29: Dimensions in the side view (desktop)	31
Fig. 30: Dimensions in the rear view (desktop)	32
Fig. 31: Dimensions in the bottom view (desktop).....	32
Fig. 32: Dimensions in the front view (wall or table mounting)	33
Fig. 33: Dimensions in the side view (wall or table mounting)	33
Fig. 34: Dimensions in the top view (wall or table mounting)	34
Fig. 35: Dimensions in the rear view (wall or table mounting)	34

2. Introduction

Kontron Embedded Computers would like to point out that the information contained in this manual may be subject to technical alteration, particularly as a result of the constant upgrading of Kontron Embedded Computers products. The attached documentation does not entail any guarantee on the part of Kontron Embedded Computers with respect to technical processes described in the manual or any product characteristics set out in the manual. Kontron Embedded Computers does not accept any liability for any printing errors or other inaccuracies in the manual unless it can be proven that Kontron Embedded Computers is aware of such errors or inaccuracies or that Kontron Embedded Computers is unaware of these as a result of gross negligence and Kontron Embedded Computers has failed to eliminate these errors or inaccuracies for this reason. Kontron Embedded Computers expressly informs the user that this manual only contains a general description of technical processes and instructions which may not be applicable in every individual case. In cases of doubt, please contact Kontron Embedded Computers.

This manual is protected by copyright. All rights are reserved by Kontron Embedded Computers. Copies of all or part of this manual or translations into a different language may only be made with the prior written consent of Kontron Embedded Computers. Kontron Embedded Computers points out that the information contained in this manual is constantly being updated in line with the technical alterations and improvements made by Kontron Embedded Computers to the products and thus this manual only reflects the technical status of the products by Kontron Embedded Computers at the time of printing.

© 2011 by Kontron Embedded Computers

Printing and duplication, even of sections, is only permissible with the express approval of





Kontron Embedded Computers GmbH

Oskar-von-Miller-Str. 1

85386 Eching

Germany

2.1. Symbols used in this Manual

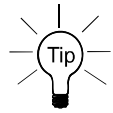
Symbol	Meaning
	This symbol indicates the danger of injury to the user or the risk of damage to the product if the corresponding warning notices are not observed.
	This symbol indicates that the product or parts thereof may be damaged if the corresponding warning notices are not observed.
	This symbol indicates general information about the product and the user manual.
	This symbol indicates detail information about the specific product configuration.
	This symbol precedes helpful hints and tips for daily use.

3. Important Instructions

This manual provides important information required for the proper operation of the CB 752 platform!

This chapter contains instructions which must be observed when working with the CB 752 platform.

3.1. Warranty Note

Due to their limited service life, parts which by their nature are subject to a particularly high degree of wear (wearing parts) are excluded from the warranty beyond that provided by law. This applies to batteries, for example.

3.2. Exclusion of Accident Liability Obligation

Kontron Embedded Computers shall be exempted from the statutory accident liability obligation if the user fails to observe the included document: "General Safety Instructions for IT Equipment" the hints in this manual or eventually the warning signs label on the device.

3.3. Liability Limitation / Exemption from the Warranty Obligation

In the event of damage to the device caused by failure to observe the included document "General Safety Instructions for IT Equipment", the hints in this manual or eventually the warning signs label on the device, Kontron Embedded Computers shall not be required to honor the warranty even during the warranty period and shall be exempted from the statutory accident liability obligation.

4. Safety Instructions



Please consider the included "General Safety Instructions for IT Equipment".



4.1. Electrostatic Discharge (ESD)

A sudden discharge of electrostatic electricity can destroy static-sensitive devices or micro-circuitry. Proper packaging and grounding techniques are necessary precautions to prevent damage. Always take the following precautions:

1. Transport boards in static-safe containers such as boxes or bags.
2. Keep electrostatic sensitive parts in their containers until they arrive at the ESD-safe workplace.
3. Always be properly grounded when touching a sensitive board, component, or assembly.
4. Store electrostatic-sensitive boards in protective packaging or on antistatic mats.

4.1.1. Grounding Methods

The following measures help to avoid electrostatic damages to the device:

1. Cover workstations with approved antistatic material. Always wear a wrist strap connected to workplace as well as properly grounded tools and equipment.
2. Use anti-static mats, heel straps, or air ionizers to give added protection.
3. Always handle electrostatically sensitive components by their edge or by their casing.
4. Avoid contact with pins, leads, or circuitry.
5. Turn off power and input signals before inserting and removing connectors or connecting test equipment.
6. Keep work area free of non-conductive materials such as ordinary plastic assembly aids and styrofoam.
7. Use field service tools such as cutters, screwdrivers, and vacuum cleaners which are conductive.
8. Always place drives and boards PCB-assembly-side down on the foam.

4.2. Instructions for the Lithium Battery

The installed SBC is equipped with a Lithium battery. When replacing the lithium battery, please follow the corresponding instructions in the chapter 10.1 "Replacing the Lithium Battery".



Caution

Danger of explosion when replacing with wrong type of battery. Replace only with the same or equivalent type recommended by the manufacturer. The lithium battery type must be UL recognized.



Do not dispose of lithium batteries in general trash collection. Dispose of the battery according to the local regulations dealing with the disposal of these special materials, (e.g. to the collecting points for dispose of batteries).

4.3. FCC Statement

This equipment has been tested and found to comply with the limits for a Class A digital device, pursuant to Part 15 of the FCC Rules. These limits are designed to provide reasonable protection against harmful interference when the equipment is operated in commercial environment. This equipment generates, uses, and can radiate radio frequency energy and, if not installed and used in accordance with the instruction manual, may cause harmful interference to radio communications. Operation of this equipment in residential area is likely to cause harmful interference in which case the user will be required to correct the interference at his own expense.

(English): This Class A digital apparatus complies with the Canadian ICES-003.

(French): Cet appareil numérique de la classe A est conforme à la norme NMB-003 du Canada.

4.4. Electromagnetic Compatibility (EU)

This product is intended only for use in industrial areas. The most recent version of the EMC guidelines (EMC Directive 2004/108/EC) and/or the German EMC laws apply. If the user modifies and/or adds to the equipment (e.g. installation of add-on cards) the prerequisites for the CE conformity declaration (safety requirements) may no longer apply.

Warning!

This is a class A product. In domestic environment this product may cause radio interference in which case the user may be required to take adequate measures.

5. Scope of Delivery

- CB 752 platform (ordered system configuration)
- Rubber feet (self adhesive)
- DC power cable
- General Safety Instructions for IT Equipment

Optional Parts

- AC/DC Adapter
- Brackets for wall or table mounting
- LVDS to DVI-D converter (internally installed)
- Mini-PCIe WLAN card (internally installed)
- WiFi antenna
- RS422/485 module (COM2) ("EASY 422/485", internally installed)
- COM3 (RS232) via USB ("EASY USB to RS232" internally installed)
- CAN bus module (internally installed)



A customer-specific configuration of the CB 752 platform with the following optional add-on modules can only be factory-provided:

- LVDS to DVI-D converter
- Mini-PCIe WLAN card
- RS422/485 module (COM2) (for more information refer to "EASY 422/485" on www.kontron.com)
- COM3 (RS232) via USB (for more information refer to "EASY USB to RS232" on www.kontron.com)
- CAN bus module

5.1. Type Label and Product Identification

The type label (product name, serial number) and the inspection status label of your CB 752 system are located on the bottom side of the device.



Fig. 1: Front view



Fig. 2: Rear view

6. Product Description

The CB 752 platform expands the Kontron line of computers, the CB series. The CB 752 platform is equipped with a Single Board Computer (Intel® Atom, N270 processor, 1.6GHz). The hardware system configuration and the robust construction with excellent mechanical stability of the CB 752 platform offer the superior qualities of a computer designed for operation in harsh industrial environment. The standard configuration of the CB 752 can be equipped with an internal 2.5" HDD (SATA or SSD) and/or a CompactFlash™ card, type I (see chapter 6.3 "Storage Media").

The CB 752 is a fanless system with a compact aluminum chassis with cooling fins. The rated voltage of the mains can be found on the type label. The type label is located at the bottom side of the device. The CB 752 can be factory-equipped with a Mini PCI express WLAN card for one or two antennas. Optionally, the platform can also be equipped with a DVI-D interface, a CAN bus interface and up to two additional serial interfaces, COM2 and COM3 (see chapter 6.1.4 "Optional Interfaces on the Front Side").



Fig. 3: Bottom view

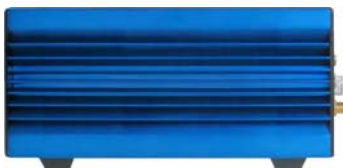

Fig. 4: Right view



Fig. 5: Front view



Fig. 6: Left view



Fig. 7: Top view



Fig. 8: Rear view



The device may be operated in all positions except with the upper side facing down.

When switching on the CB 752, make sure that the air openings on the front side (Fig. 9, pos. 3) and the rear side (Fig. 12, pos. 2) and the cooling fins of the chassis are not obstructed (covered) by any objects. To provide sufficient heat dissipation for the cooling of the device, do not cover the cooling fins of the CB 752. Do not place any objects on the device. When installing the platform, please note the clearance recommendation in the chapter 11.2 “Mechanical Specifications”.

6.1. Front View

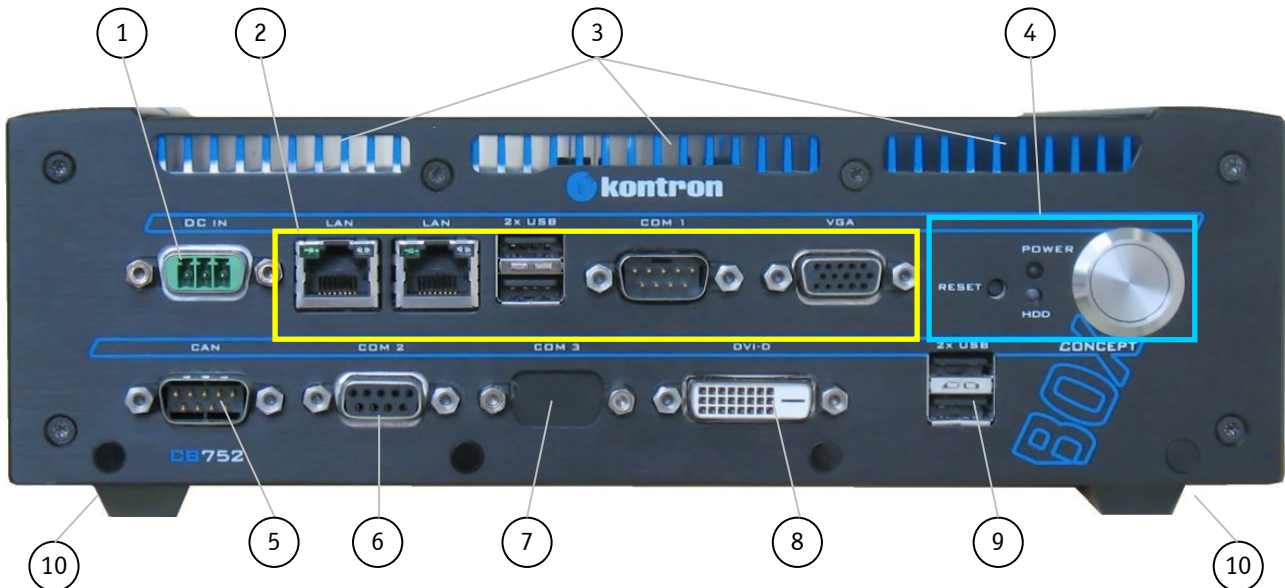

Fig. 9: CB 752 – Front view

- | | |
|--|---|
| 1 DC IN power connector | 6 Serial port (COM2) [(RS232/RS422/RS485 at customer's option); shown as RS485] |
| 2 External connectors of the installed SBC | 7 Prepared for Serial Port (COM3); RS232 via USB (optional) |
| 3 Air openings at the front side | 8 DVI-D (Single Link) interface (optional) |
| 4 Controls and indicators | 9 2x USB ports |
| 5 CAN bus interface (optional) | 10 Rubber feet |

6.1.1. DC IN – Direct Current Connector

The 3-pin connector (Fig. 9, pos. 1) provides the power connection of the CB 752 platform to the appropriate main power supply. Please pay attention to chapter 8.1 “Connecting to DC or AC Main Power Supply”.

- DC power supply:** using the DC power cord (included).
- AC power supply:** using the optional AC/DC adapter.

6.1.2. Controls and Indicators

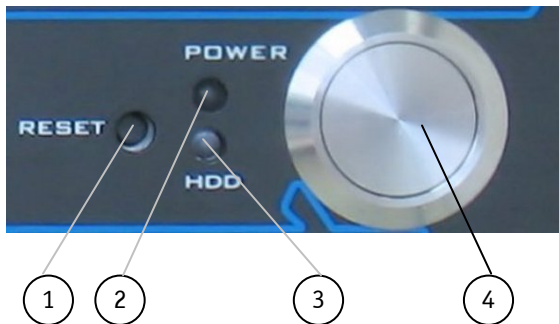

- 1 RESET button
- 2 Power LED
- 3 HDD activity LED
- 4 Power button

Fig. 10: CB 752 – Controls and Indicators

6.1.2.1. Power Button

Press this button (Fig. 10, pos. 4) to switch the system on or off.



Please note the BIOS setup settings (BIOS Setup / Chipset / South Bridge Configuration / Restore on AC Power Loss, setup options: **Power On**/ Power Off). “Power On” is the default setting. Please also note the description in chapter 10.2 “Protection against Overheating”.

Prerequisite:

The CB 752 has to be connected to an appropriate main power supply (DC or AC via AC/DC adapter).



Even when the system is turned off via the power button there is still a standby-voltage of 5 VSb on the SBC.

Switching the system off using the power button does not disconnect the device from the mains. The unit is only completely disconnected from the mains, when the power cord is disconnected either from the mains or the unit. Therefore, the power cord and its connectors must always remain easily accessible.

6.1.2.2. Power LED and HDD LED

The power LED (Fig. 10, pos. 2) and the HDD LED (Fig. 10, pos. 3) which are located on the front side of the CB 752 platform indicate the system status.

System	System Status	Color of the Power LED
CB 752 (The DC IN connector is connected to the main power supply.)	The system is in standby mode	orange
	The system is operational.	green
	Voltage, temperature or battery error	red

	Activity of the installed Storage Media	Color of the HDD LED
CB 752 (The DC IN connector is connected to the main power supply.)	CF card only	green
	SATA HDD or SATA-SSD only	red
	CF card and SATA HDD/SATA SSD simultaneously	orange

6.1.2.3. RESET-Button

To restart the system, e. g. when the system is not responding, press the reset button (Fig. 10, pos. 1).



During a reset, all Data in the main memory (RAM) will be erased. The system reboots without needing to switch the computer off and on again.

6.1.3. External Interfaces of the SBC Board at the Front Side

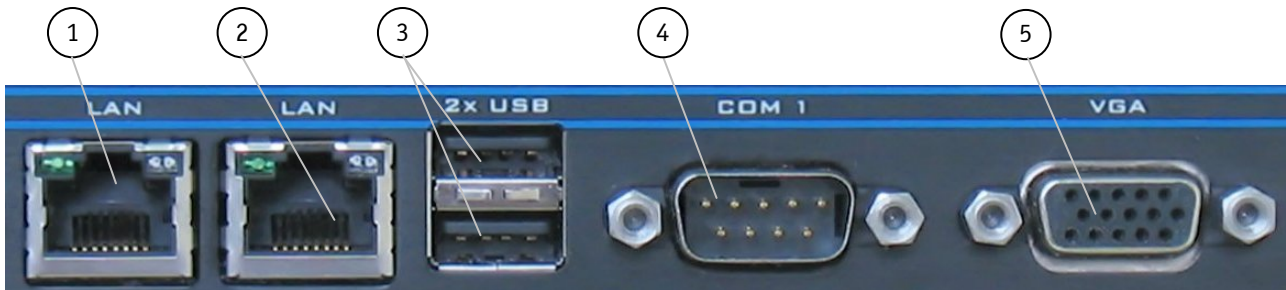

Fig. 11: External Interfaces of the integrated SBC

- | | |
|--------------------------------------|---|
| 1 LAN1 port (RJ45) (10/100/1000Mbps) | 4 Serial port (COM1), configured as RS232 |
| 2 LAN2 port (RJ45) (10/100/1000Mbps) | 5 VGA port |
| 3 2x USB 2.0 port | |

6.1.3.1. LAN Ports

These ports (Fig. 11, pos. 1 and pos. 2) consist of RJ45 connectors with integrated LEDs and support a transfer rate of 10/100/1000Mbps.

Left LED Color	Link Status	Right LED Color	Link Speed
Off	No Link	Off	10 Base-T
Green	Link is established	Green	100 Base-T
Green	Link is established	Orange	1000 Base-T

6.1.3.2. USB 2.0 Ports

You can connect various USB devices to these two USB 2.0 interface connectors (Fig. 11, pos. 3).

6.1.3.3. Serial Port (COM1)

The serial port COM1 (Fig. 11, pos. 4) consists of a 9-pin, RS232 configured D-SUB connector that allows the connection of a serial peripheral.

6.1.3.4. VGA Port

This port (Fig. 11, pos. 5) consists of a 15-pin D-SUB connector. You can connect an analog monitor to this connector.

6.1.4. Optional Interfaces on the Front Side

On customer request, the configuration of the CB 752 platform can be expanded with the following interfaces. The expansion of the system and the custom settings can only be provided by the manufacturer. The corresponding pin assignments for your customized system configuration can be found in chapter 12.



The expansion options for the CB 752 platform can be found in the “Configuration Guide” on our web site: www.kontron.com by selecting the product.

6.1.4.1. Optional DVI-D Interface (Single Link)

This interface (Fig. 9, pos. 8) is the external DVI-D connector of the internal LVDS to DVI-D converter. The DVI interface only supports digital data transfer with maximum resolutions of 1280 x 1024 (SXGA). A DVI-D cable has to be used (not included).



Please note that the default BIOS setup setting (BIOS Setup / Advanced / Video Function Configuration / Flat Panel Type) is SVGA 800x600.

6.1.4.2. Optional Serial Port (COM2), configurable as RS422/RS485

This serial port (Fig. 9, Pos. 6) can be custom configured as RS422 or RS485.



The customer specific configuration of this serial port of the CB 752 platform as RS422 and/or RS485 can only be performed by the manufacturer. When ordering a system with a RS422 or RS485 serial port, you need to specify the requirements (configuration) of this port. For a custom configuration of this port as RS422 and/or RS485, please note the “EASY 485/422” documentation “Quick Reference Guide” on our web site www.kontron.com.

6.1.4.3. Optional serial Port COM3 (RS232) via USB

If an additional serial port is needed, a RS232 interface can be installed to the position marked with COM3 (Fig. 9, pos. 7). In this case the upper USB port at the rear side (Fig. 12, pos. 3) is not functional (see chapter 6.2.2 “USB Ports”).



If you have ordered the CB 752 equipped with the additional serial interface COM3 (Fig. 9, pos. 7), please note that only the lower USB port (Fig. 12, pos. 3) at the rear side is functional (refer to the section 6.2.2 “USB Ports”).

The CB 752 system with equipped COM3 (Fig. 9, pos. 7) is delivered with mounted cover to the upper not functional USB port (Fig. 12, pos. 3). Do not remove this cover.

6.1.4.4. Optional CAN Bus interface

This interface (Fig. 9, pos. 5) can only be factory-configured to the customer's specifications. The installed LPC-to-CAN bus module provides a galvanic isolation of 500VDC.



When ordering a system with a CAN bus interface, you need to specify the requirements (configuration) of this port. See following settings options.

SJA Base Address

Address Range
0x340 to 0x35F
0x320 to 0x33F
0x300 to 0x31F
0x220 to 0x23F
0x200 to 0x21F ¹
0x140 to 0x15F
0x120 to 0x13F
0x100 to 0x11F

Table 1: SJA-Base Address Settings

SJA-Interrupt

IRQ
15
11
10
7
5
4
3

Table 3: SJA-Interrupt Settings

NVRAM-Operation Mode

Mode
IO-mode
Memory at C0000
Memory at D0000

Table 2: NVRAM-Operation Mode Settings

6.2. Rear Side

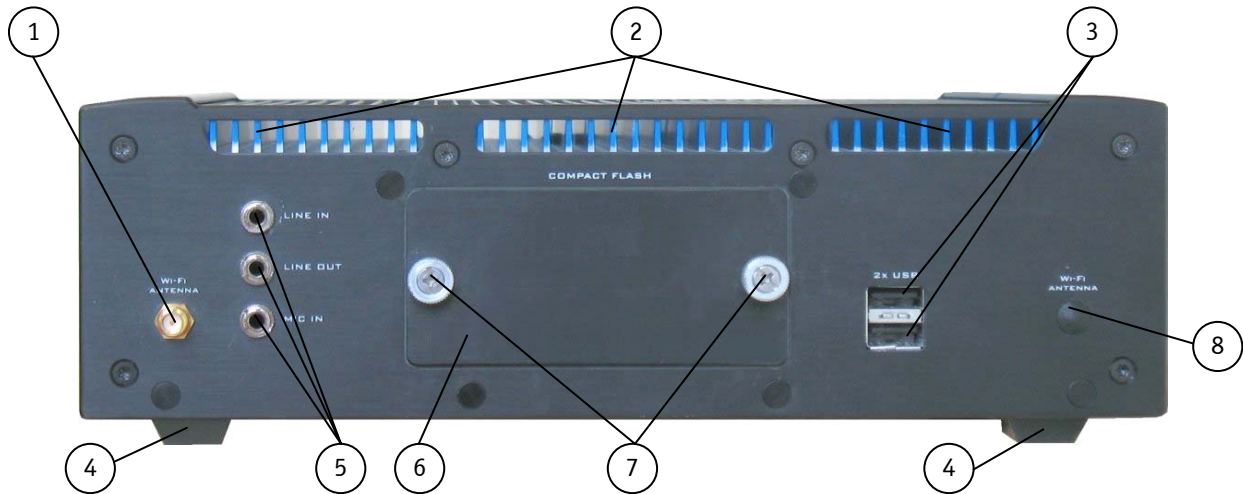

Fig. 12: CB 752 rear side with one (of two possible) WiFi antenna connector

- | | |
|---|--|
| 1 Reverse (RP) SMA connector for WLAN antenna (Mini PCIe WLAN card and antenna are optional) | 5 Audio (Line-In, Line-Out, Mic-In) |
| 2 Air openings at the rear side | 6 Access cover of the CF slot (onboard) and of the lithium battery |
| 3 2x USB 2.0 port (available only for CB 752 configurations without COM3; refer to the section 6.1.4.3 and 6.2.2) | 7 Knurled screws securing the access cover to the cabinet |
| 4 Rubber feet | 8 Covered cutout (only systems ordered with one antenna or without WiFi) |

6.2.1. Audio (LINE IN, LINE OUT and MIC IN)

To these Jacks (3.5 mm; Fig. 12, pos. 5) loudspeakers/headphones (Line-Out), a recording/playing device (Line –In) and a microphone (Mic-In) can be connected.

6.2.2. USB Ports

The CB 752 platform provides two USB2.0 ports on the rear side (Fig. 12, pos. 3). You can connect various USB devices to these USB 2.0 interface connectors.



If you have ordered the CB 752 equipped with the additional serial interface COM3 (Fig. 9, pos. 7), please note that only the lower of the USB ports (Fig. 12, pos. 3) at the rear side is functional (refer also to the section 6.1.4.3 "Optional serial Port COM3 (RS232) via USB").

The CB 752 system with equipped COM3 (Fig. 9, pos. 7) is delivered with mounted cover to the upper not functional USB port (Fig. 12, pos. 3 as shown in Fig. 13). Do not remove this cover.



The not functional USB port is covered for CB752 configuration with equipped COM3 (option)

Fig. 13: Covered USB port for system configuration with equipped COM3 port

6.2.3. WiFi /WLAN (Option)

Depending on the ordered system configuration, the CB 752 platform can be equipped with WiFi hardware expansion (with one or two antennas). If you have ordered a system configuration including WLAN, at the rear side a Reverse (RP) SMA-connector is installed (Fig. 12, pos. 1) for screwing on the provided WLAN antenna.

6.2.3.1. Antenna

During the installation of the CB 752 system an antenna (not provided) (Fig. 14) will be screwed on to the RP SMA connector (Fig. 12, pos. 1). The antenna can be tilt and rotated in the appropriate position to get the optimal transmission and reception quality.



Fig. 14: WLAN (WiFi) Antenna

- 1 Reverse (RP) SMA antenna connector
- 2 Hinge for positioning the antenna

6.2.4. CF Slot Access Cover

To gain access to the CF slot or to the CF card and to the lithium battery, you have to loosen the two knurled screws (Fig. 12, pos. 7) and to remove the access cover (Fig. 12, pos. 6).



During operation the CF slot access cover must be attached and secured with the knurled screws (Fig. 12, pos. 7).

6.3. Storage Media

By default, an internal 2.5" SATA-/SSD HDD (not accessible) and/or a CompactFlash™ card (IDE) (accessible) can be installed in the CB 752 platform. The CompactFlash™ card can be accessed from the rear side via the removable access cover (see Fig. 12, pos. 6).

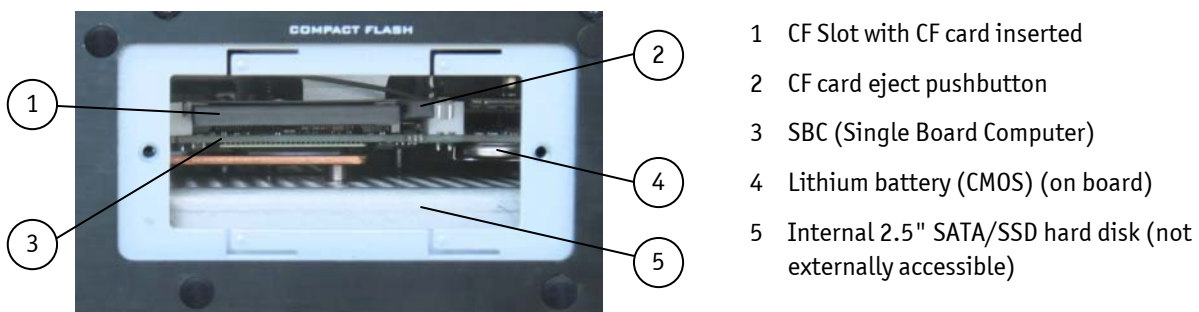

Fig. 15: Detail of the rear side with the CF slot access cover removed

6.4. Chassis with cooling Fins

The applied “heat pipe” cooling method provides adequate cooling of the device during operation and performs a one-way thermal transfer to the chassis. Three sides of the aluminum chassis (left, upper and right side) are covered with cooling fins. The cooling fins provide heat dissipation during operation.



To provide sufficient heat dissipation for the cooling of the CB 752 platform, never cover the cooling fins of the chassis. Do not place any objects onto the device.



Fig. 16: Right side of the chassis

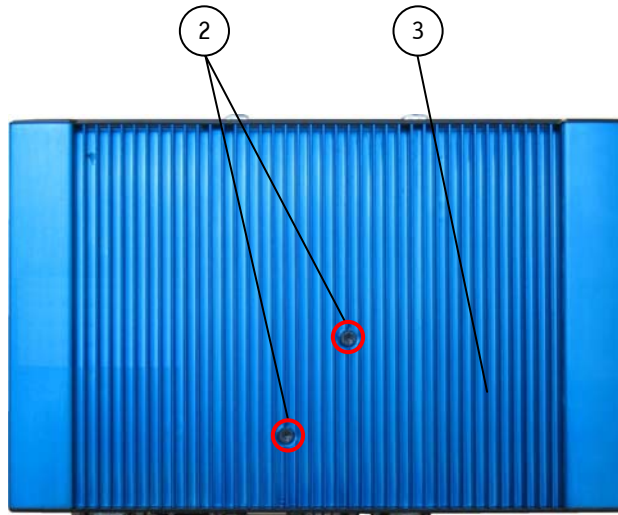

Fig. 17: Top side of the chassis



Fig. 18: Left side of the chassis

- | | |
|--|--|
| 1 Cooling fins of the chassis on the right side | 3 Cooling fins of the chassis on the top side |
| 2 Torx screws that fix the internal heat transfer plate (with integrated heat pipe) to the chassis | 4 Cooling fins of the chassis on the left side |



Do not loosen or remove the two torx screws (Fig. 17, pos. 2) that fix the internal heat transfer plate (with integrated heat pipe) to the chassis.

6.5. Bottom Side

At the bottom side are located: the type label, the inspection status label and if applicable, the license sticker.

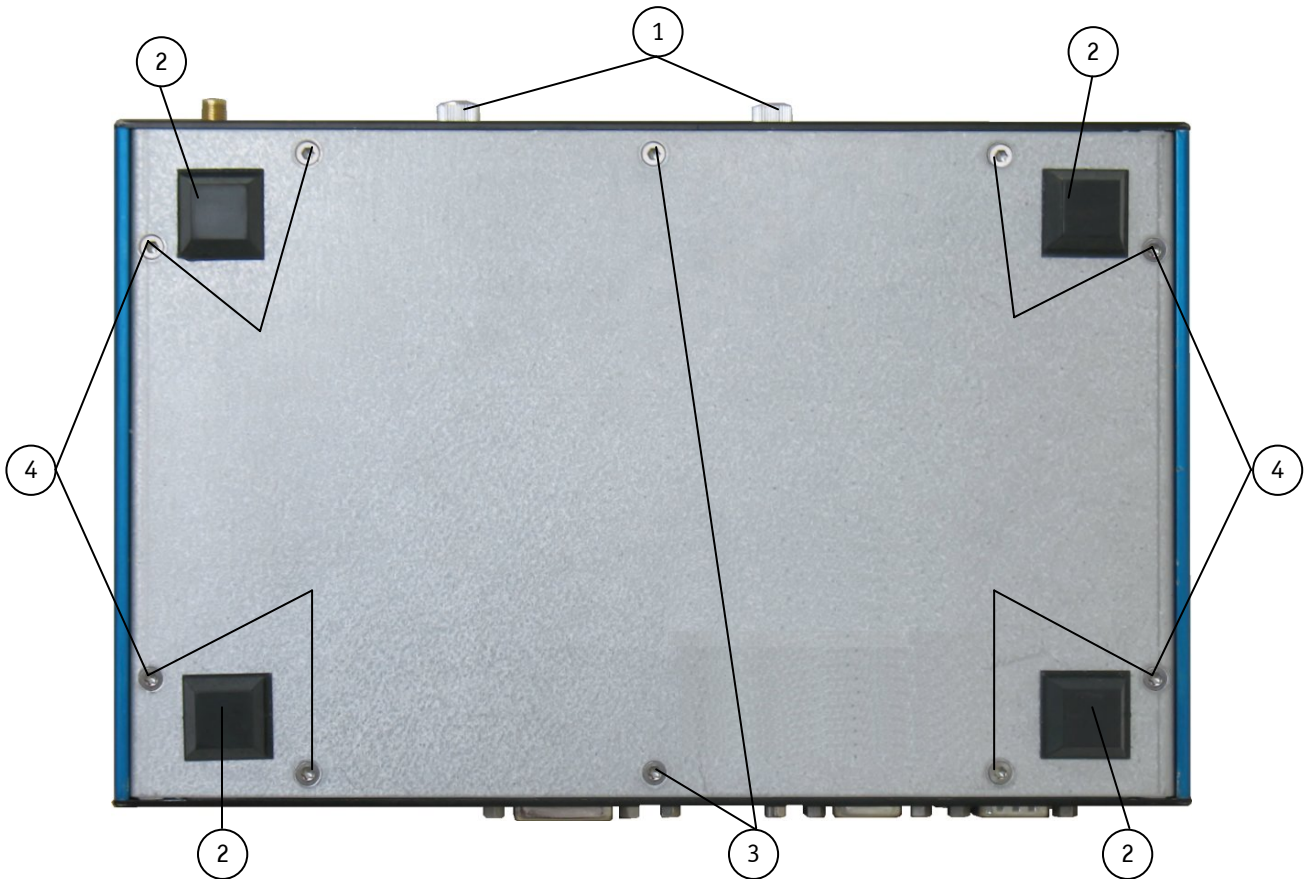

Fig. 19: Bottom side

- | | |
|--|--|
| 1 Knurled screws of the CF slot access cover | 3 Countersunk screws M3x6 DIN7991 A2 torx for mounting of the bottom section of the device |
| 2 Rubber feet of the desktop version | 4 Countersunk screws M3x6 DIN7991 A2 torx for mounting of the bottom section of the device and of the optional brackets (for wall or table mounting) |

6.6. DC Power Cord

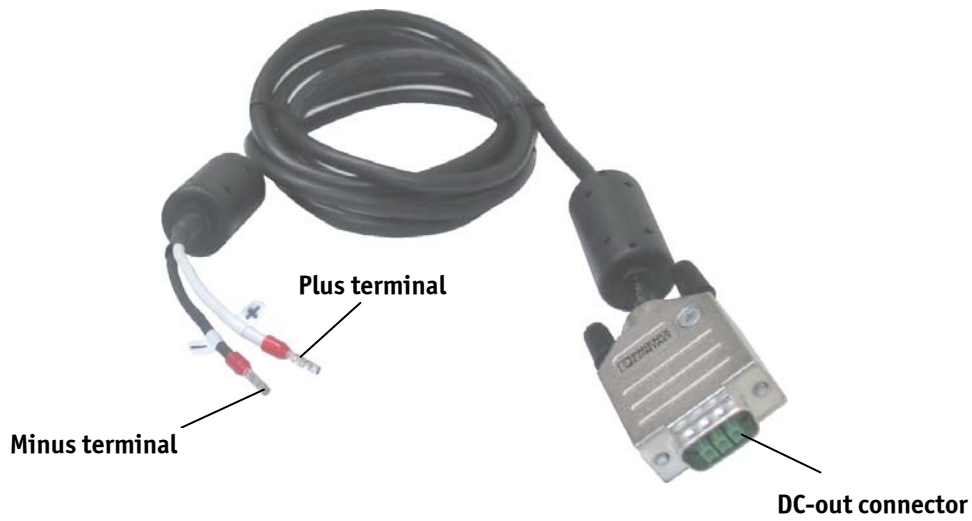

Fig. 20: DC power cord

6.7. AC/DC-Adapter (Option)

The external AC/DC adapter is provided with an AC power cord.

AC/DC-Adapter

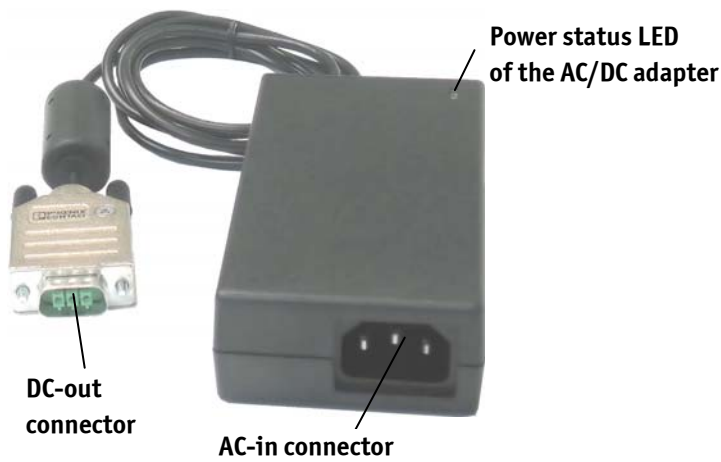

Fig. 21: AC/DC adapter





Fig. 22: AC power cord

AC/DC-Adapter	
AC input	DC output
100-240 V	24 VDC
1.5 A	2.5 A max.
50-60 Hz	

7. Assembly, Disassembly

7.1. Handling internal Components

This chapter contains important information on working safely with internal components. Please follow these instructions when handling cards.

	<p>When opening the device, always follow the descriptions in this manual.</p> <p>Before opening the device, make sure that the system is switched off and disconnected from the main power supply.</p>
	<p>Please follow the safety instructions for components that are sensitive to electrostatic discharge (ESD). Failure to observe this warning notice may result in damage to the device or the latter's components.</p>
	<p>When installing/removing CF cards and replacing the lithium battery, observe the corresponding instructions in the provided document "General Safety Instructions for IT Equipment".</p> <p>Activities such as working inside the system or handling the expansion cards have to be carried out by the service person for this area or a suitably instructed user.</p>

7.1.1. Inserting and Removing the CF card

The on-board CompactFlash™ slot allows the operation of a CompactFlash™ card type I. The access cover of the CompactFlash™ slot is located at the rear side of your CB 752 platform.



Before opening the CF card access cover to insert or to remove a CompactFlash™ card, the system must be switched off and disconnected from the main power supply. Also disconnect peripheral devices from the CB 752!

7.1.1.1. Inserting the externally accessible CompactFlash™ Card

To install the CompactFlash™ card, please perform the following steps:

1. Switch off the system and disconnect it from the AC or DC main power supply.
2. Loosen the knurled screws (Fig. 12, pos. 7) that secure the CF slot access cover (Fig. 12, pos. 6) to the chassis.
3. Remove the CF slot access cover.
4. Insert the CompactFlash™ card with the connectors facing forward into the CF slot (Fig. 15).
5. Press the CompactFlash™ card carefully into the CF card slot as far as it will go.
6. Insert the laces of the CF card access cover into the centering notches of the chassis. Secure the CF slot access cover with the knurled screws by tightly fastening the screws.

7.1.1.2. Removing the externally accessible CompactFlash™ Card

To remove the CompactFlash™ card, please perform the following steps:

1. Switch off the system and disconnect it from the AC or DC main power supply.
2. Loosen the knurled screws (Fig. 12, pos. 7) that secure CF slot access cover (Fig. 12, pos. 6) to the cover.
3. Remove the CF slot access cover.
4. To remove the CF card, press the eject button (Fig. 15, Pos. 2).
5. Remove the CF card from the CF slot and from the device.
6. Insert the laces of the CF card access cover into the centering notches of the chassis. Secure the CF slot access cover with the knurled screws by tightly fastening the screws.



During operation the CF slot access cover must be attached and secured with the knurled screws.

8. Starting Up



The rated voltage of the mains (AC/DC) must agree with the voltage value on the type label.

8.1. Connecting to DC or AC Main Power Supply

The DC input connector (Fig. 9, Pos. 1) is located on the front side of the CB 752 platform.

8.1.1. Connecting the CB 752 Platform to a DC Main Power Supply

To connect the CB 752 platform to a corresponding DC main power supply, please perform the following steps:

1. Connect the 3-pin connector of the DC power cord to the DC input connector (Fig. 9, Pos. 1) of the CB 752 platform. The DC input connector of the CB 752 platform is located on the front side and is marked "DC IN".
2. The DC main power supply must be switched off via a 2-pole disconnect device to make sure that no voltage is present at the terminals during the connecting procedure.
3. Connect the other end of the DC power cord to the connections of the 24V DC main power supply. Pay attention to the polarity of the connections. The wires of the DC power cord are marked plus (+) and minus (-) (see Fig. 20).
4. Switch on the DC main power supply via the disconnect device.



It must be ensured that the system can be powered ON and OFF via a readily accessible two-pole disconnect device that shall be incorporated in the building installation wiring (e.g. overload protection switch).

The CB 752 platform is only completely isolated from the mains by disconnecting the DC power cord from the mains or from the device. For this reason, ensure that there is easy access to the power cord, including its plugs.

8.1.2. Connecting the CB 752 Platform to an AC Main Power Supply using the AC/DC Adapter

The CB 752 platform can be connected via the AC/DC adapter to an AC main power supply.



The CB 752 platform may only be connected via the optional AC/DC adapter to an AC main power supply.



The plug of the AC power cord meets the requirements of the country where you have purchased your CB 752 platform. Make sure that your AC power cord has the approval of the country you want to use it.

The AC power cord is also the disconnect device for the system. For this reason, ensure that there is easy access to the mains outlet of the main power supply and that it is located close to the system.

The AC/DC adapter must be placed freely and must not be covered.

To connect the CB 752 platform to a corresponding AC main power supply, please perform the following steps:

1. Connect the 3-pin connector of the AC/DC adapter to the DC input connector (Fig. 9, pos. 1) of the CB 752 platform. The DC input connector is located on the front side and is marked "DC IN".
2. Connect the AC power cord to the AC/DC adapter.
3. Connect the other end of the AC power cord to a corresponding mains outlet.



Make sure that the AC main power supply is properly grounded and that the AC power cord is intact and undamaged. Ungrounded power supplies are not allowed.

8.2. Operating Systems and Hardware Component Drivers

Your system can be supplied optionally with a pre-installed operating system.

If you have ordered your CB 752 with a pre-installed operating system, all drivers are installed in accordance with the system configuration ordered (optional hardware components). Your system is fully operational when you switch it on for the first time.

If you have ordered CB 752 without a pre-installed operating system, you will need to install the operating system and the appropriate drivers for the system configuration you have ordered (optional hardware components) yourself.



You can download the relevant drivers for the installed hardware from our web site at www.kontron.com by selecting the product.

Pay attention to the manufacturer specifications of the operating system and the integrated hardware components.

9. Installing the CB 752 Platform



Please follow the corresponding instructions in this manual when installing/mounting the CB 752 platform.

The system has to be mounted and installed only by the service person for this area familiar with the associated dangers.

Ensure there is sufficient air circulation around the device when installing the CB 752 platform. Observe the clearance values around the device recommended in chapter 11.2 “Mechanical Specifications”.

When installing, make sure that the openings for air intake and exhaust on the device are free and not obstructed by objects.

Operate the device within the intended temperature range to prevent possible overheating (see chapter 11.3 “Environmental Specifications”, chapter 4 “Safety Instructions” and chapter 10.2, “Protection against Overheating”).

The voltage feeds must not be overloaded. Adjust the cabling and the external overcharge protection to correspond with the electrical data indicated on the type label.

The type label is located on bottom side of the device.

9.1. CB 752 Platform - Desktop

The CB 752 platform will be delivered as desktop version with rubber feet attached to the bottom side of the device. When positioning the device, pay attention to the restriction range at the front and rear side of the platform. See chapter 11.2.1 “CB 752 Desktop Dimensions”.

9.2. Mounting using the Brackets

For mounting the CB 752 platform on a wall (vertical) or on a table (horizontal) two mounting brackets (see Fig. 25 and Fig. 26) are available (see chapter 11.2.2 "Dimensions for Wall and Table Mounting"). It requires little effort to attach the mounting brackets to the bottom side of the CB 752 platform. Use the installed torx screws (Fig. 19, pos. 4). To do so, the rubber feet have to be removed first.



Depending on the surface on which the CB 752 platform is to be placed (e.g. wooden panel, metal plate, wall, wall mount cabinet), use appropriate screws (e.g. wood screws, M5 screws with nut, Spax screws with anchor).

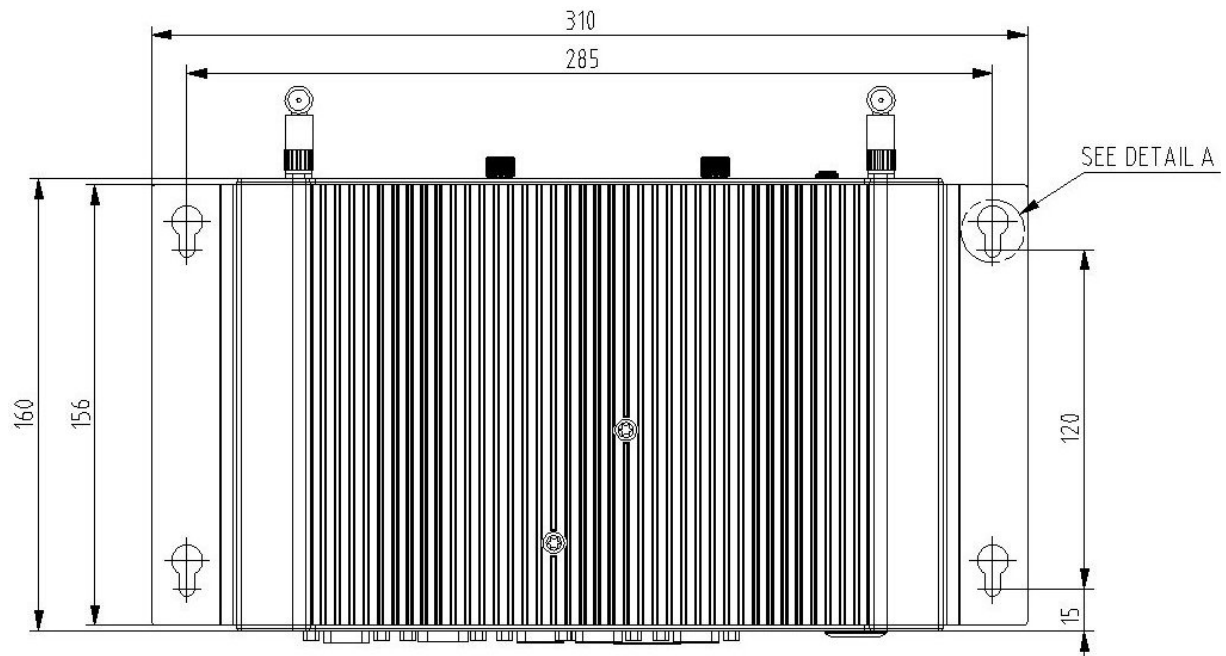

Fig. 23: CB 752 with mounting brackets installed

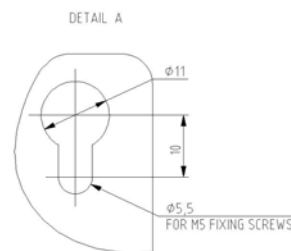

Fig. 24: Detail: Hanging holes



Fig. 25: Left mounting bracket (optional)



Fig. 26: Right mounting bracket (optional)



10. Maintenance and Prevention

Equipment from Kontron Embedded Computers requires only minimum servicing and maintenance for problem-free operation.

- ❑ For light soiling, clean the CB 752 with a dry cloth.
Carefully remove dust from the surface of the cooling fins of the chassis using a clean, soft brush.
- ❑ Stubborn dirt should be removed using a mild detergent and a soft cloth.

10.1. Replacing the Lithium Battery

The SBC card (Single Board Computer) of the CB752 platform is equipped with a lithium battery.

	<p>When opening the device, always follow the descriptions in this manual.</p> <p>Before opening the device, make sure that the system is switched off and disconnected from the main power supply.</p> <p>Use only non-conductive tools for replacing/inserting the lithium battery into/from the battery holder.</p>
	<p>Please follow the safety instructions for components that are sensitive to electrostatic discharge (ESD). Failure to observe this warning notice may result in damage to the device or the latter's components.</p>

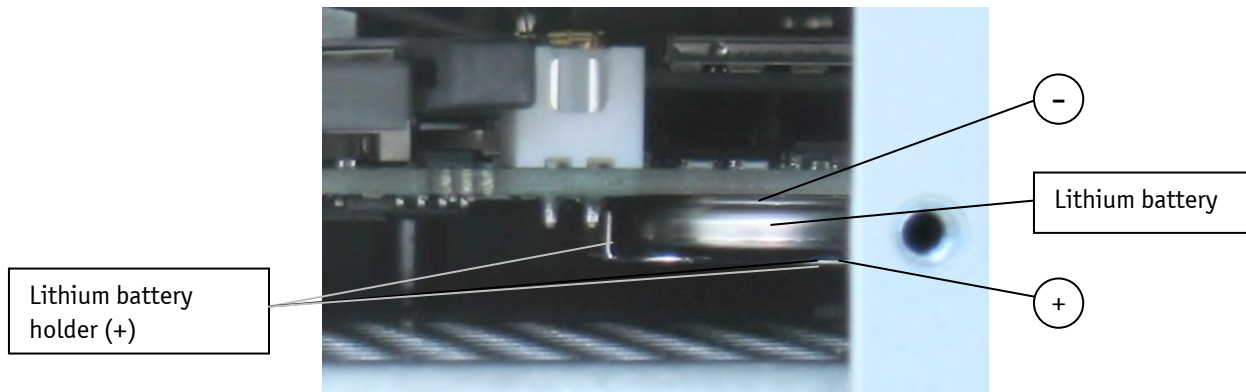

Fig. 27: Rear side detail without CF access cover

To replace the lithium battery, please perform the following steps:

1. Switch off the system and disconnect it from the main power supply.
2. Loosen the two knurled screws at the rear side of the device (see Fig. 12, pos. 7). Remove the CF slot access cover (Fig. 12, pos. 6).
3. Remove the lithium battery from the battery holder (see Fig. 27) using a non-conductive tool.
4. Insert the new lithium battery into the battery holder. Pay attention to the polarity of the battery. The positive pole has to face down to the holder (see Fig. 27).
5. Re-attach the access cover and secure it by tightening the knurled screws.

**Caution**

Danger of explosion when replacing with wrong type of battery. Replace only with the same or equivalent type recommended by the manufacturer. The lithium battery type must be UL recognized.



Do not dispose of lithium batteries in general trash collection. Dispose of the battery according to the local regulations dealing with the disposal of these special materials, (e.g. to the collecting points for dispose of batteries).



10.2. Protection against Overheating

The system comes with a protective function against overheating.

The implemented protective function against overheating will turn off the system when the specified maximum environmental temperature (+60 °C) is exceeded during operation (caused by external influences) and the internal temperature has reached 85 °C.



For the CB752 platform:

A temperature value of 85°C at the internal temperature sensor equates to an environmental temperature of 65 °C.

Any unsaved data will be lost when the system is switched off by the protective function against overheating.

The device turns on automatically and performs a system start as soon as the internal temperature decreases to 70 °C.

11. Technical Data

CB 752		
Installed SBC	SBC with Intel® Atom™ processor	
Processor	Intel® Atom™ N270 1.6 GHz	
Storage Media	<p>* Optional configuration [depending on the ordered system configuration (see also "Configuration Guide")]</p> <p>1x 2.5" SATA/SSD HDD and/or 1x CompactFlash™ Type I (IDE)</p>	
Lithium Battery	CR2032; 3.0 V; 0.18Ah (UL recognized)	
BIOS	AMI	
Interfaces	<p>Interfaces at the front side:</p> <p>1x VGA 1x COM1(RS232) 4x USB (2.0) 2x LAN (10/100/1000Mbps)</p> <p>Options:</p> <p>1x DVI-D (Single Link) 1x CAN bus, galvanically isolated 1x COM2 (optional, configurable via EASY RS422/485 module) 1x COM3 (RS232) via USB</p>	<p>Interfaces at the rear side:</p> <p>1x Line-In 1x Line-Out 1x Microphone-In 2x USB (2.0) for system configuration without equipped optional serial port COM3 or 1x lower USB (2.0) port for system configuration equipped with the optional serial port COM3</p> <p>Options:</p> <p>1x WiFi (optional; with 1x or 2x antenna connector)</p>
Internal Onboard Slots	1x mini PCIe x1 for optional WLAN card	
Controls (at the front side)	Power button RESET button	
Indicators (at the front side)	Power LED Hard disk activity LED	
DC IN Connector (at the front side)	24 VDC input connector	
Power Consumption per Slot (Mini PCIexpress)	Max. 5 W	
Mains Power Supply	See type label	



Only CB 752 systems equipped with the optional COM3 are delivered with a mounted cover to the upper not functional USB port. Do not remove this cover.

* The corresponding document "Configuration Guide" and the manual of the installed motherboard can be downloaded from our web site: www.kontron.com by selecting the product.

11.1. Electrical Specifications

The corresponding electrical specifications for your CB 752 platform can be found on the type label of the system.

11.2. Mechanical Specifications

11.2.1. CB 752 Desktop Dimensions



For a sufficient air circulation around the device, we recommend not to place (mount) or operate any other devices within the restriction area marked with "40mm" (all around the cooling fins of the chassis) (see Fig. 28).

The restriction area marked with "100mm" (at the front and rear side of the platform) is reserved for cable connections (see Fig. 29).

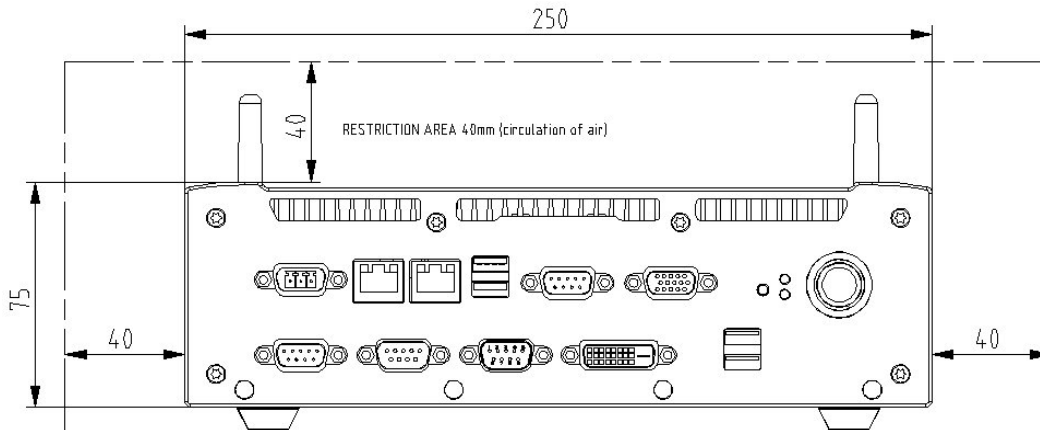

Fig. 28: Dimensions in the front view (desktop)

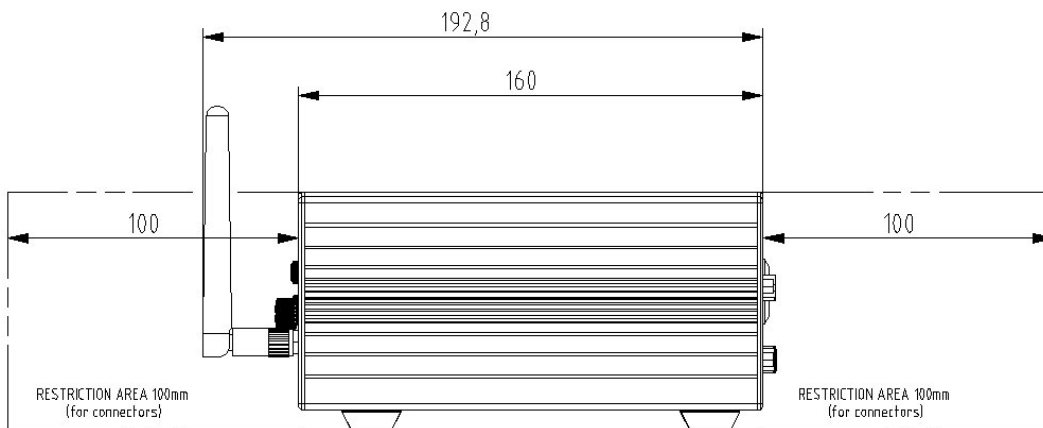

Fig. 29: Dimensions in the side view (desktop)

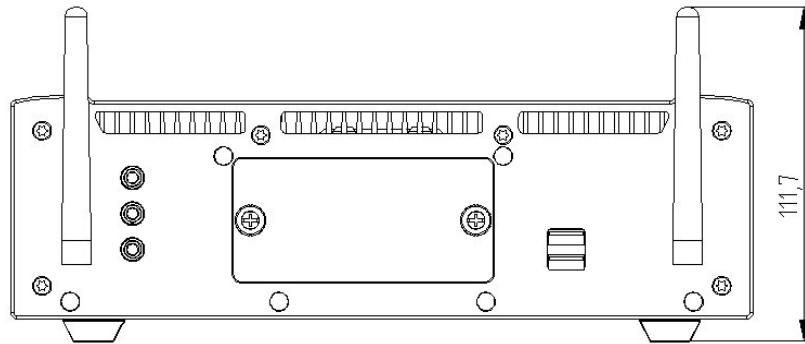

Fig. 30: Dimensions in the rear view (desktop)

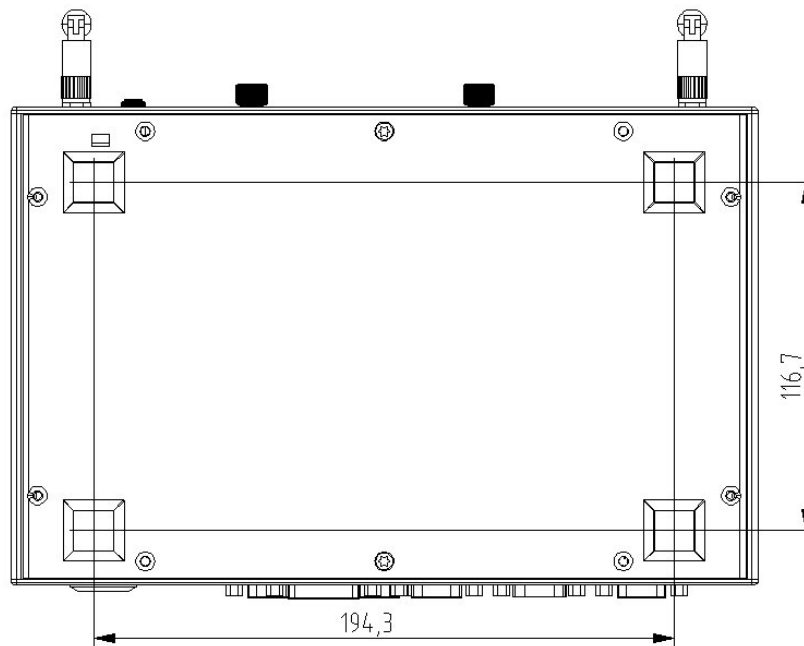

Fig. 31: Dimensions in the bottom view (desktop)

11.2.2. Dimensions for Wall and Table Mounting



For a sufficient air circulation around the device, we recommend not to place (mount) or operate any other devices within the restriction area marked with "40mm" (all around the cooling fins of the chassis) (see Fig. 32).

The restriction area marked with "100mm" (at the front and rear side of the platform) is reserved for cable connections (see Fig. 33).

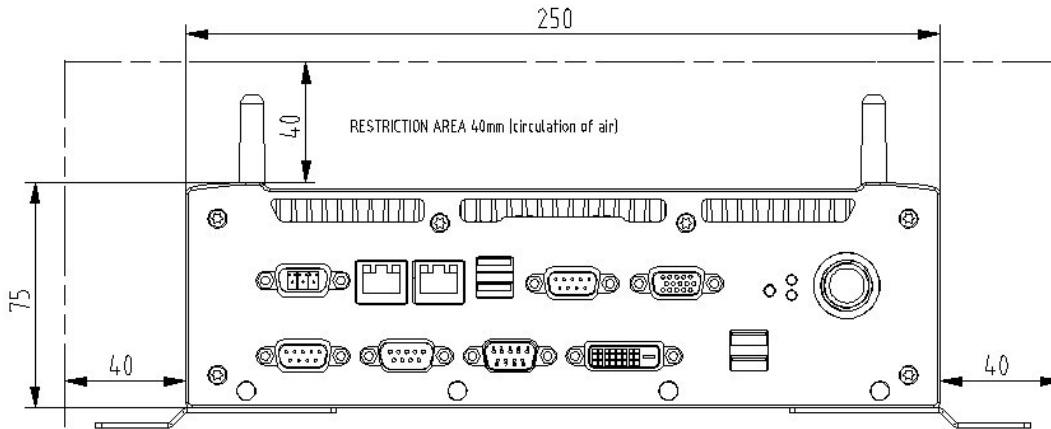

Fig. 32: Dimensions in the front view (wall or table mounting)

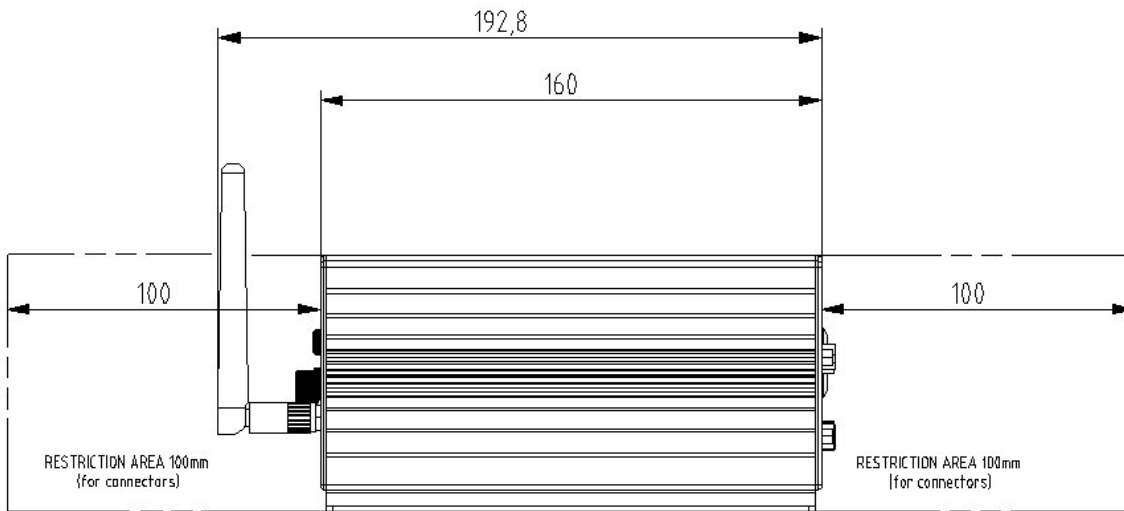

Fig. 33: Dimensions in the side view (wall or table mounting)

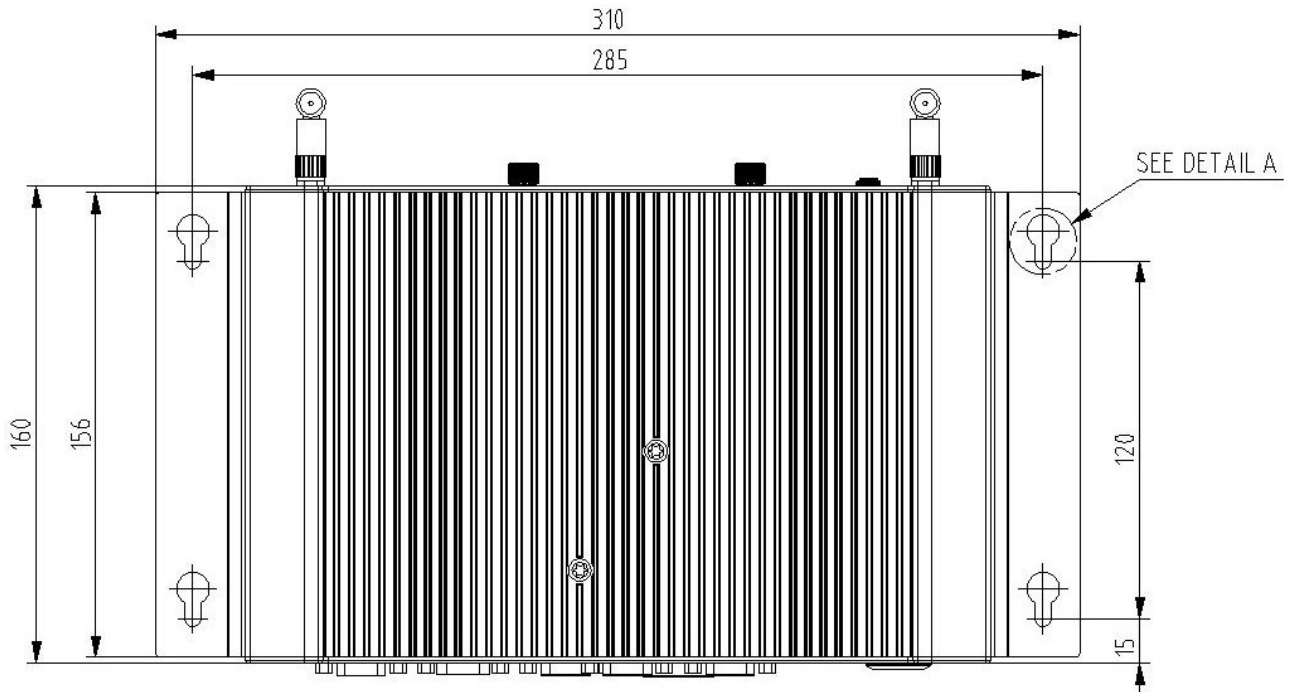

Fig. 34: Dimensions in the top view (wall or table mounting)

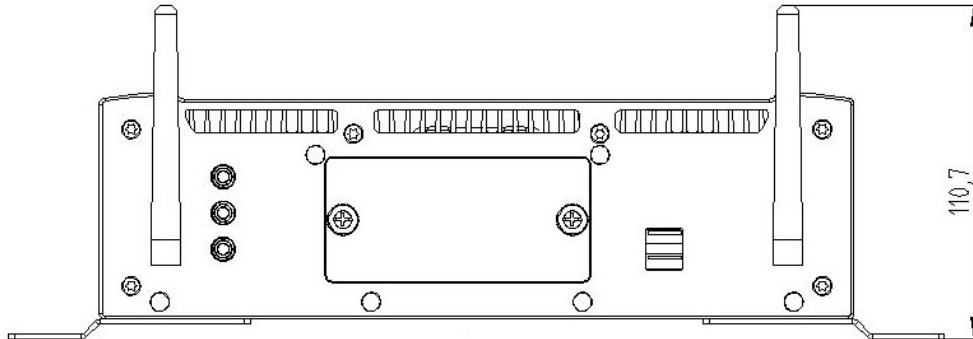

Fig. 35: Dimensions in the rear view (wall or table mounting)

11.3. Environmental Specifications

Operating Temperature / Relative Humidity	-15 ... +60 °C, (+5 ... +140 °F), not condensing (for system configuration with rotating storage media, e.g. with HDD) -20 ... +60 °C, (-4 ... +140 °F), not condensing (for system configuration with non-rotating storage media, e.g. with CF)
Storage / Transport Temp. / Relative Humidity	-25 ... +70 °C / 5-95 % @ 40 °C, not condensing (-13 ... +158 °F / 5-95 % @ 104 °F, not condensing)
Max. Operation Altitude	3.048 m (10.000 ft)
Max. Storage / Transport Altitude	10.000 m (32.810 ft)
Operating Shock	5 G, 11 ms duration, half sine
Storage / Transit Shock	15 G, 11 ms duration, half sine
Operating Vibration	10 – 500 Hz, 0.5 G
Storage / Transit Vibration	10 – 500 Hz, 1.0 G

11.4. EC Directives and Standards

EC Directives	
Low voltage directive (electrical safety)	General Product Safety Directive (GPSD) 2001/95/EG Low Voltage Directive (LVD) 2006/95/EG
EMC directive	EMC Directive 2004/108/EG
EC marking	Council Directive 93/68/EEC

Electrical Safety	Standards
EUROPE	Information technology equipment - Safety - Part 1: General requirements EN 60950-1: 2006
U.S.A. / CANADA	to meet UL60950-1:2006

EMC	Standards
EUROPE	Generic emission standard for industrial environments (Emission): EN 61000-6-4:2007 Generic standards - Immunity for industrial environments (Immunity): EN 61000-6-2:2005
U.S.A.	FCC 47 CFR Part 15, Class A
CANADA	ICES-003, Class A

12. Standard Ports – Pin Assignment

Low-active signals are identified with a minus sign.

12.1.1. DC IN Connector

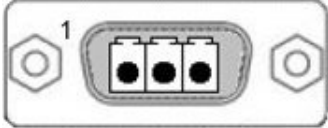
Pin	Signal Name	3-pin DC-In connector (male)
1	0V (input)	
2	NC	
3	+24 VDC (input)	

12.1.2. Serial Port COM1, COM2 and COM3 (RS232)

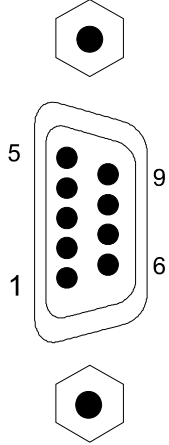
Pin	Signal Name	9-pin D-SUB connector (male)
1	DCD (Data Carrier Detect)	
2	RXD (Receive Data)	
3	TXD (Transmit Data)	
4	DTR (Data Terminal Ready)	
5	GND (Signal Ground)	
6	DSR (Data Set Ready)	
7	RTS (Request to Send)	
8	CTS (Clear to Send)	
9	RI (Ring Indicator)	

12.1.3. Serial Port COM2 (RS422/RS485) configured as RS422 (4-channel mode)

Pin	Signal Name	9-pin D-SUB connector (female)
1	TxD- (Transmit Data-)	
2	RxD+ (Receive Data+)	
3	TxD+ (Transmit Data+)	
4	RxD- (Receive Data-)	
5	GND (Signal Ground)	
6	RTS- (Request to Send-)	
7	RTS+ (Request to Send+)	
8	CTS+ (Clear to Send+)	
9	CTS- (Clear to Send-)	

12.1.4. Serial Port COM2 (RS422/RS485) configured as RS485 (4-wire mode), full duplex (bus master)

Pin	Signal Name	9-pin D-SUB connector (female)
1	TxD- (Transmit Data-)	
2	RxD+ (Receive Data+)	
3	TxD+ (Transmit Data+)	
4	RxD- (Receive Data-)	
5	GND (Signal Ground)	
6	RTS- NC	
7	RTS+ NC	
8	CTS+ NC	
9	CTS- NC	

12.1.5. Serial Port COM2 (RS422/RS485) configured as RS485 (2-wire mode), half duplex

Pin	Signal Name	9-pin D-SUB connector (female)
1	Data (-)	
2	NC	
3	Data (+)	
4	NC	
5	GND (Signal Ground)	
6	NC	
7	NC	
8	NC	
9	NC	

12.1.6. VGA Port

Pin	Signal Name	15-pin D-SUB connector (female)
1	Analog red output	
2	Analog green output	
3	Analog blue output	
4	NC	
5-8	GND	
9	+5 V (DDC)	
10	GND	
11	NC	
12	SDA (DDC)	
13	TTL HSync	
14	TTL VSync	
15	SCL (DDC)	

12.1.7. CAN Bus Connector

For settings, please refer to chapter 6.1.4.4 "Optional CAN Bus interface".

Pin	Signal Name	9-pin D-SUB connector (male)
1	NC	
2	CANL (galvanically separated)	
3	CANOV (galvanically separated)	
4	NC	
5	NC	
6	NC	
7	CANH (galvanically separated)	
8	NC	
9	NC	

12.1.8. USB Port

Pin	Signal Name	4-pin USB connector Type A Version 2.0
1	VCC	
2	Data-	
3	Data+	
4	GND	

13. Technical Support

For technical support, please contact our Technical Support department:

Tel: +49 (0) 8165/77 112
 Fax: +49 (0) 8165/77 110
 e-Mail: support@kontron.com

Make sure you have the following information on hand when you call:

- the unit part id number (PN),
- the serial number (SN) of the unit (the serial number can be found on the type label, placed on the bottom side of the system).

Be ready to explain the nature of your problem to the service technician.

If you have questions about Kontron Embedded Computers or our products and services, you may reach us at the aforementioned numbers, or at: www.kontron.com or by writing to:

Kontron Embedded Computers GmbH
 Oskar-von-Miller-Str. 1
 85386 Eching
 Germany

13.1. Returning Defective Merchandise

Before you return any device that is not functioning correctly to Kontron Embedded Computers, please work through the following list:

1. Download the form for returning a device with an RMA No. [RMA (**R**eturn of **M**aterial **A**uthorization)] from our website www.kontron.com / Support /RMA Information; contact our Customer Service department to obtain an RMA No.:
 Fax: (+49) 8165-77 412
 e-Mail: service@kontron.com
2. Ensure that you have received an RMA No. from Kontron Customer Services before returning any device. Write this number clearly on the outside of the package that you are sending to us.
3. Describe the fault that has occurred.
4. Please provide the name and telephone number of a person we can contact to obtain more information, where necessary. Where possible, please enclose all the necessary customs documents and invoices.
5. When returning a device:
 - Pack it securely in its original box.
 - Enclose a copy of the RMA form with the consignment.

Corporate Offices

Europe, Middle East & Africa	North America	Asia Pacific
Oskar-von-Miller-Str. 1 85386 Eching/Munich Germany Tel.: +49 (0)8165/ 77 777 Fax: +49 (0)8165/ 77 219 info@kontron.com	14118 Stowe Drive Poway, CA 92064-7147 USA Tel.: +1 888 294 4558 Fax: +1 858 677 0898 info@us.kontron.com	17 Building,Block #1,ABP. 188 Southern West 4th Ring Beijing 100070, P.R.China Tel.: + 86 10 63751188 Fax: + 86 10 83682438 info@kontron.cn

