

# Installation Guide

## Installing Copper Pillars, Thermal Solution & 3.5"-eIO on 3.5"-SBC





### ➤ Application

The installation guide is applicable to Kontron's 3.5"-SBC products.

Depending on the ordered configuration, Kontron's 3.5"-SBC board may be supplied with a screw copper pillar kit, a thermal solution kit and / or a 3.5"-eIO I/O expansion kit to facilitate developmental test and evaluation at the customer side by providing a quick and easy heat dissipation tool as well as a flexible and of-the-shelf I/O expansion solution.

### ➤ Screw Copper Pillar Kit

The screw copper pillar kit is intended for elevating 3.5"-SBC as well as 3.5"-eIO if any to ensure proper airflow and to prevent overheating. It consists of the items listed in either of the configurations shown in the following table depending on 3.5"-SBC.





Kit	Screw Copper Pillar Kit			
Item	①	②	③	④
Legend				
P/N	0H020E504000100L	0H020E401900100L	0H0101301500100L	0H0101300500100L
Description	Long Copper Pillar	Short Copper Pillar	M3 Screw X 15L	M3 Screw X L5
Kit Configuration 1	P/N: 0ZHK35SBC0000001			
Quantity	4	3	4	1
Kit Configuration 2	P/N: 0ZHK35SBC0000002			
Quantity	4	3	-	4



Depending on installation configurations, some items may not be used or only partially used. Refer to the installation figures below for the exact quantity of each item used in each installation.

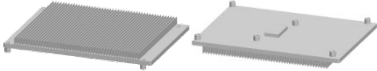

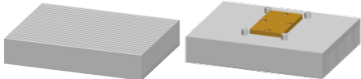
## ➤ Thermal Solution Kit

The thermal solution kit is intended for dissipating heat from the processor mounted on 3.5"-SBC. It consists of the items listed in either of the configurations shown in the following table depending on how many thermal solution mounting holes there are around the processor on 3.5"-SBC and what type of thermal solution is used.

Kit	Thermal Solution Kit	
Item	⑤	⑥
Kit Configuration Type 1	In case of 2 mounting holes around the processor + passive thermal solution Refer to relevant 3.5"-SBC datasheet for kit P/N	
Legend	 Depending on 3.5"-SBC	
P/N	Depending on 3.5"-SBC	0H0100300600100L
Description	Heatsink	M3 Screw X L6
Quantity	1	2
Kit Configuration Type 2	In case of 4 mounting holes around the processor + passive thermal solution Refer to relevant 3.5"-SBC datasheet for kit P/N	
Legend	 Depending on 3.5"-SBC	
P/N	Depending on 3.5"-SBC	0H0100300600100L
Description	Heatsink	M3 Screw X L6
Quantity	1	4

## ➤ 3.5"-eIO I/O Expansion Kit

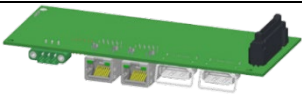
The 3.5"-eIO I/O expansion kit is intended for additional I/O ports and functions stacked on 3.5"-SBC. It consists of the items listed in the following table.

Kit	3.5"-eIO I/O Expansion Kit		
P/N	Depending on 3.5"-eIO Refer to relevant 3.5"-SBC or 3.5"-eIO datasheet for kit P/N		
Item	⑦	②	④
Legend	 (Depending on 3.5"-eIO)		
P/N	Depending on 3.5"-eIO	0H020E401900100L	0H0101300500100L
Description	I/O Expansion Card	Short Copper Pillar	M3 Screw X L5
Quantity	1	3	3

The installation procedure varies depending on which kit(s) is(are) ordered with 3.5"-SBC.

**➤ In Case of Ordering Thermal Solution Kit from Kontron**

To install the thermal solution on 3.5"-SBC, follow the steps shown in either of the following figures depending on the ordered configuration.

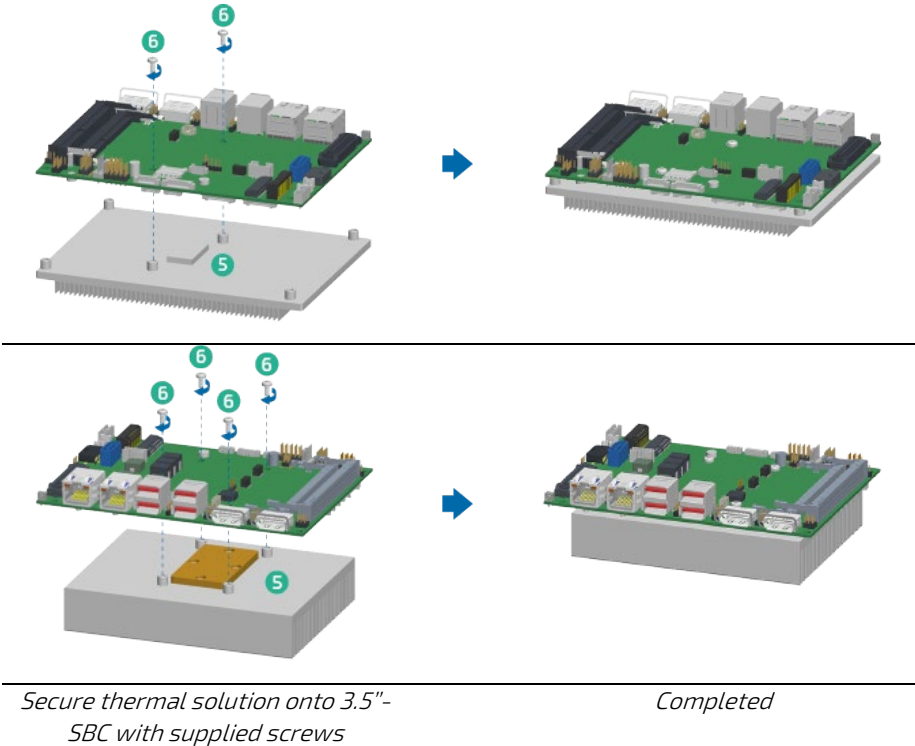

➤ In Case of Ordering Thermal Solution Kit + Screw Copper Pillar Kit from Kontron

To install the thermal solution and copper pillars on 3.5"-SBC, follow the steps shown in either of the following figures depending on the ordered configuration.

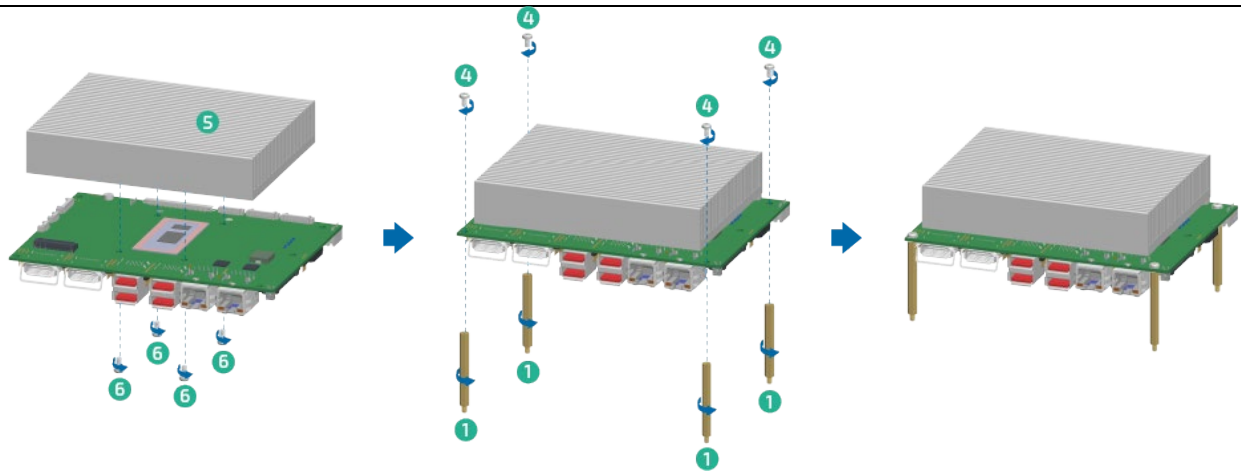
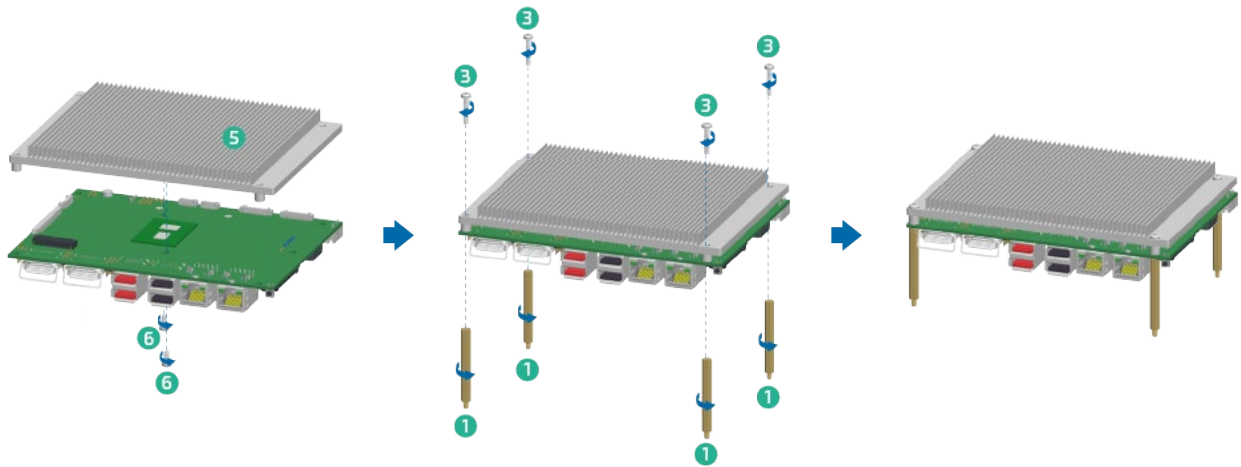

*Secure thermal solution onto 3.5"-SBC with supplied screws*

*Secure long copper pillars onto 3.5"-SBC with supplied screws*

*Completed*

## ➤ In Case of Ordering Thermal Solution Kit + Screw Copper Pillar Kit + 3.5"-eIO Expansion Kit from Kontron

To install the thermal solution, copper pillars and 3.5"-eIO on 3.5"-SBC, follow the steps shown in either of the following figures depending on the ordered configuration.

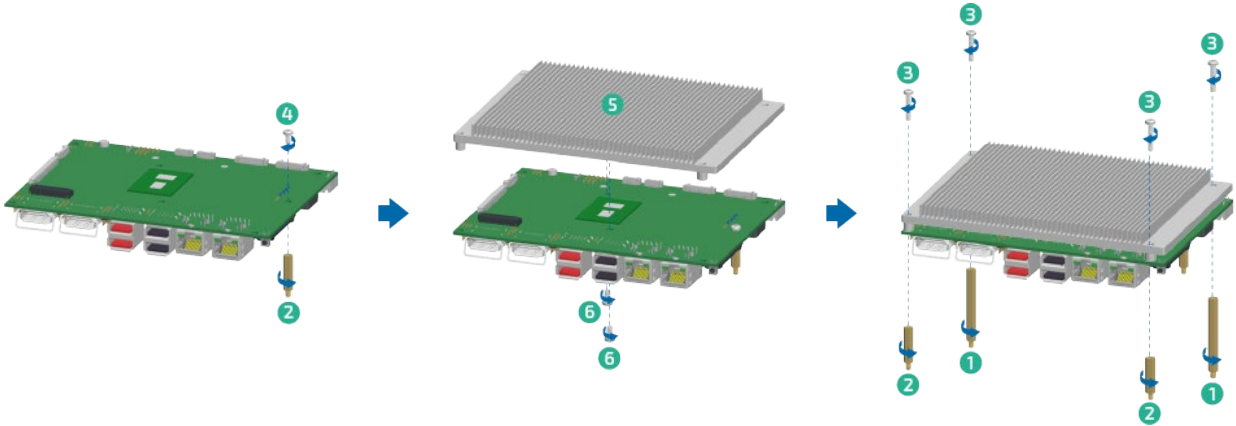

*Secure a short copper pillar onto 3.5"-SBC with supplied screw first*

*Secure thermal solution onto 3.5"-SBC with supplied screws*

*Secure 2 short copper pillars and 2 long copper pillars onto 3.5"-SBC with supplied screws*

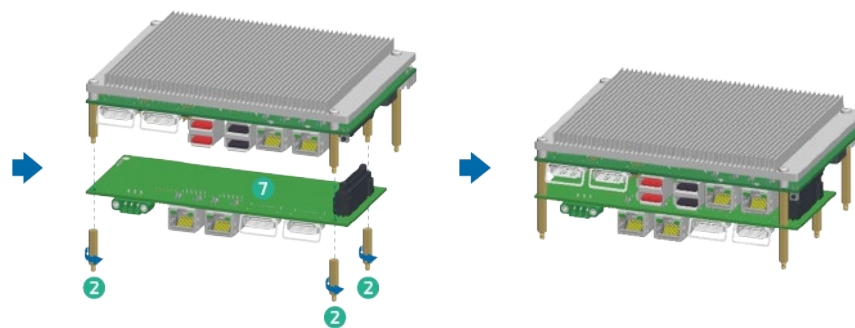

*Secure 3.5"-eIO onto 3.5"-SBC with the other short copper pillars*

*Completed*

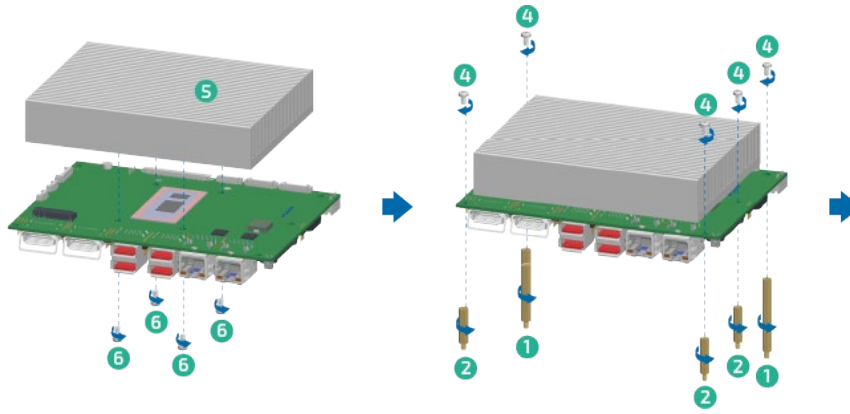

*Secure thermal solution onto 3.5"-SBC with supplied screws*

*Secure 3 short copper pillars and 2 long copper pillars onto 3.5"-SBC with supplied screws*

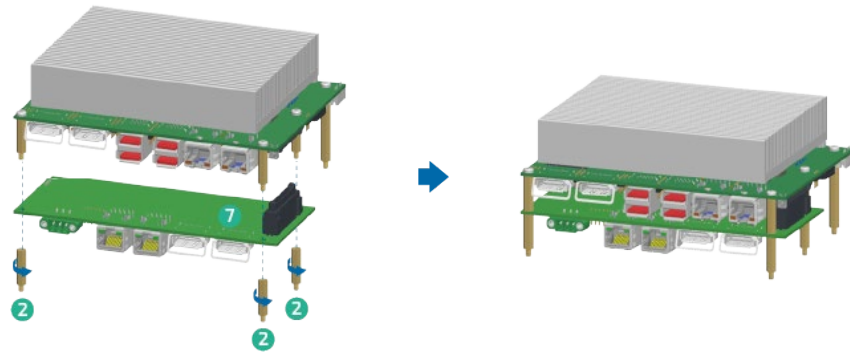

*Secure 3.5"-eIO onto 3.5"-SBC with the other short copper pillars*

*Completed*

## ➤ In Case of Ordering 3.5"-eIO I/O Expansion Kit from Kontron

To install the 3.5"-eIO along with the customer-designed thermal solution on 3.5"-SBC, follow the steps shown in the following figure.

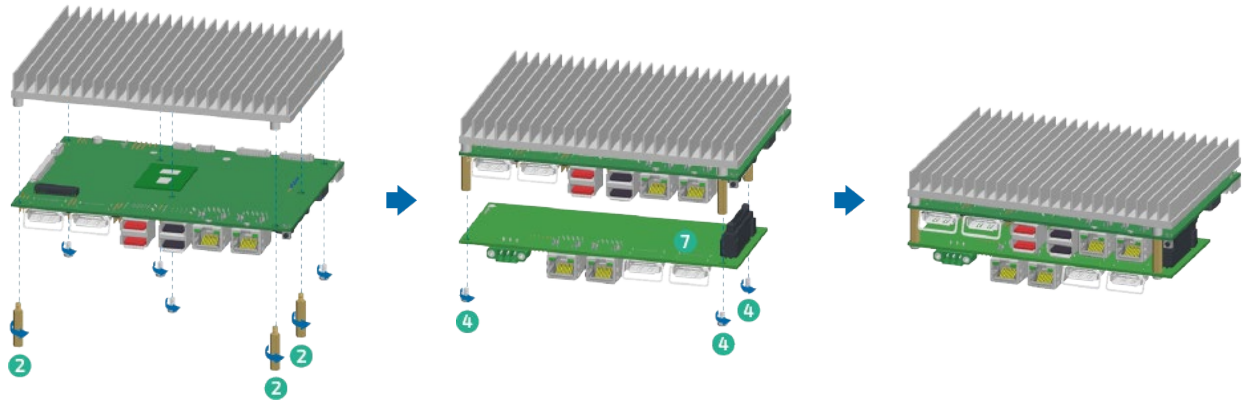

*Secure customer-designed thermal solution onto 3.5"-SBC with supplied short copper pillars and customer-provided screws*

*Secure 3.5"-eIO onto 3.5"-SBC with supplied screws*

*Completed*

---

To perfectly accommodate the customer-design thermal solution to 3.5"-SBC, the thermal solution should be designed according to the following requirements.



- Standoff height = 4.5 mm
  - Standoff internal female thread diameter = M3
  - Standoff internal female thread length = 6.0 mm
  - The quantity of thermal solution mounting holes around the processor varies depending on 3.5"-SBC. The standoff quantity should match the number correspondingly.
- 

### Global Headquarters

Kontron Europe GmbH

Gutenbergstraße 2  
85737 Ismaning, Germany  
Tel.: + 49 821 4086-0  
info@kontron.com

[www.kontron.com](http://www.kontron.com)

**kontron**  
The Power of IoT