

Model DCC FAMILY

5,10, and 20 Channel Counter/Timer Cards

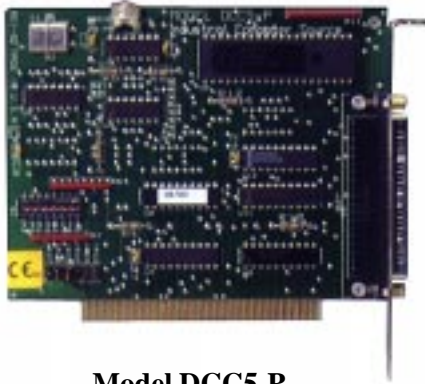

Model DCC5-P



Model DCC20-P

FEATURES

- 5 Independent 16-Bit Counters
- Cascadable Counters
- Measures Frequency to 7Mhz
- Up/Down and Binary/BCD Counting
- Programmed Frequency Output
- Alarm Comparators on Two Counters
- Supported by Major Application Software Packages
- 10 or 20 Independent 16-Bit Counters
- Binary/BCD - Up/Down
- Programmable Count Source/Gate Selection
- Programmable Input/Output Polarities
- Interrupt Handling
- 1 MHz TTL Oscillator
- Counters Internally Cascadable



DESCRIPTION

The DCCx-P family consists of three models, the DCC5-P, DCC10-P, and the DCC20-P. The DCC20-P contains four AM9513 System Timing Controller LSI circuits. Each AM9513 consists of five independent 16-bit up/down counters. The DCC10-P contains two AM9513 circuits and the DCC5-P contains one. The DCC5-P does however, contain an 8-bit input port and an 8-bit output port in addition to the AM9513. The DCC10-P and DCC20-P are physically the same board except for the difference in the number of counters. On the DCC10-P and DCC20-P, the signals for each counter are available on independent 26-pin headers. On the DCC5-P, the signals are available on a DB37 male connector.

The counters can be programmed to count up or down in either binary or BCD. A selection of various internal and external frequency sources and outputs may be chosen as inputs for individual counters with software selectable active-high or active-low polarities. Each counter may be gated by either software or hardware.

Each counter has a single dedicated output pin. Considerable versatility for configuring both the input and the gating of individual counters is provided. This not only permits dynamic re-assignment of inputs under software control, but also allows multiple counters to use a single input, allows a single gate input to control more than one counter, and allows for cascading.



SPECIFICATIONS

Model DCC Family

COUNTER TIMER

Counter Type

AM9513

Number of Counters

One offering 5, 10, and 20 independent channels

Counter Clock

1.00 Mhz ($\pm 0.01\%$,
0 to 70° C)

DIGITAL I/O (DCC5-P ONLY)

Number of Lines

8 input and 8 output, LS245 Buffered

Logic

Latched LSTTL

Input Low

-0.5 to 0.8VDC

Input High

2.0 to 5.0VDC

Sink Current

24 mA

Source Current

18 mA

GENERAL

I/O Space

4 bytes

IRQ Selections

2 through 7 (DCC5 & 10 & 20-P)

9 through 12, 14 through 15 (DCC10 & 20-P)

Power Required

+5VDC @ 400mA typical

Software Provided

Sample programs in BASIC & C

Setup Aid Utility

PHYSICAL

Temperature Range

Operating: 0 to +50° C

Storage: -25 to +85° C

Relative Humidity

0 to 90%, RHNC

Size

1/2 Slot

Connector Type

37-pin D-shell, male (DCC5-P)

26-pin IDC header (DCC10/20-P)

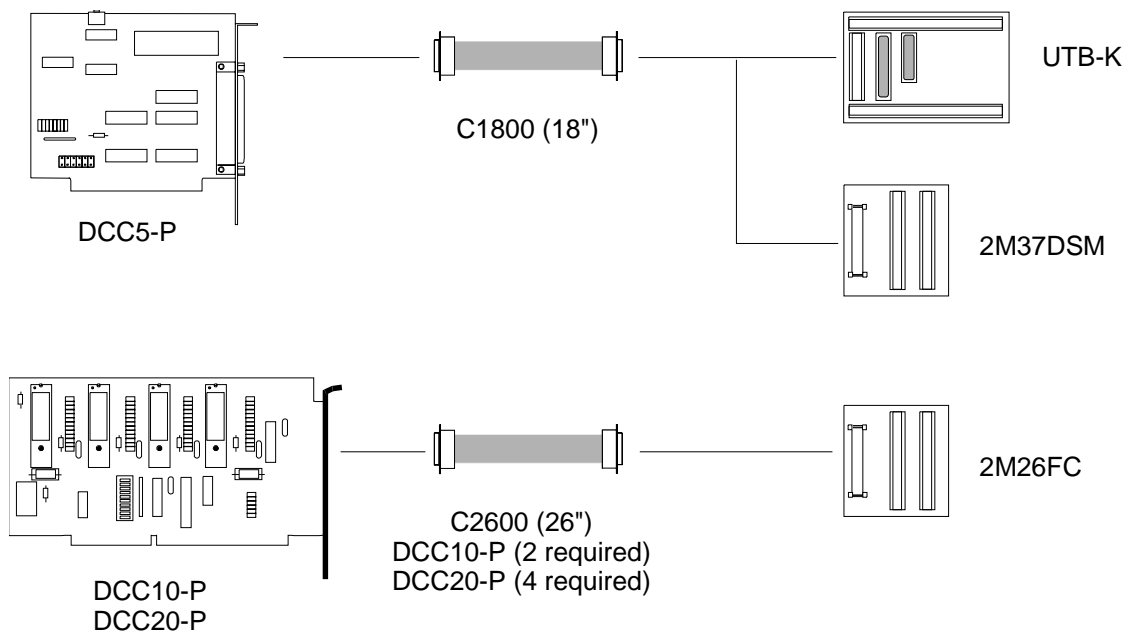

CONNECTOR PINOUTS

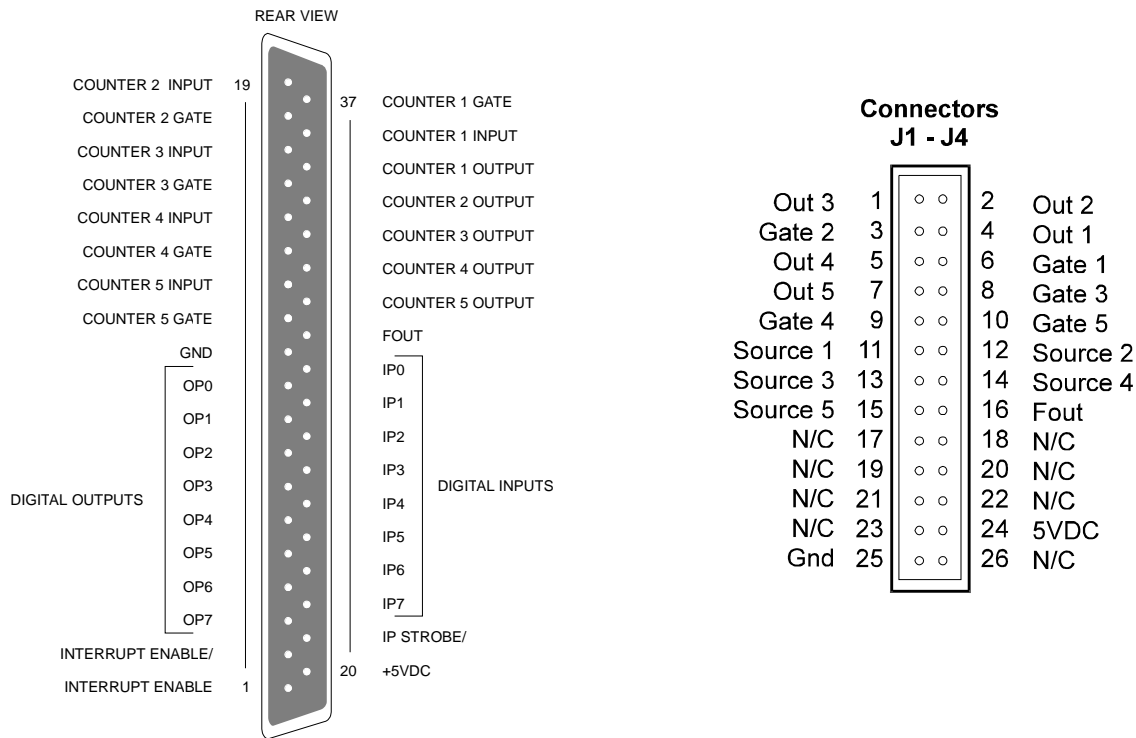

ORDERING GUIDE

MODELS

Model DCC5-P

5 Counter/Timer Board, manual, software

Model DCC10-P

10 Counter/Timer card, manual, software

Model DCC20-P

20 Counter/Timer card, manual, software

ACCESSORIES

Model UTB-K

Termination card/Metal Enclosure

Model UTB

Termination board

Model 2M37DSM

Screw termination panel

ACCESSORIES (CONTINUED)

Model C1800

18" (487 mm) cable

Model 2TK2D-6

6" section of SNAPTRACK

Model TKAD

Din rail mounting clips for SNAPTRACK (2 required)

Model 2M26FC

Termination card for DCC10-P or DCC20-P, one required for each counter chip (maximum of 4)

Model C2600

36" (914 mm) cable for interface between DCC10-P or DCC20-P & 2M26FC, one required for each counter chip/termination card (maximum of 4)



6260 Sequence Drive
 San Diego, CA 92121
 800 523-2320
 fax 858 677-0895
www.icsadvent.com