

# » User Guide «

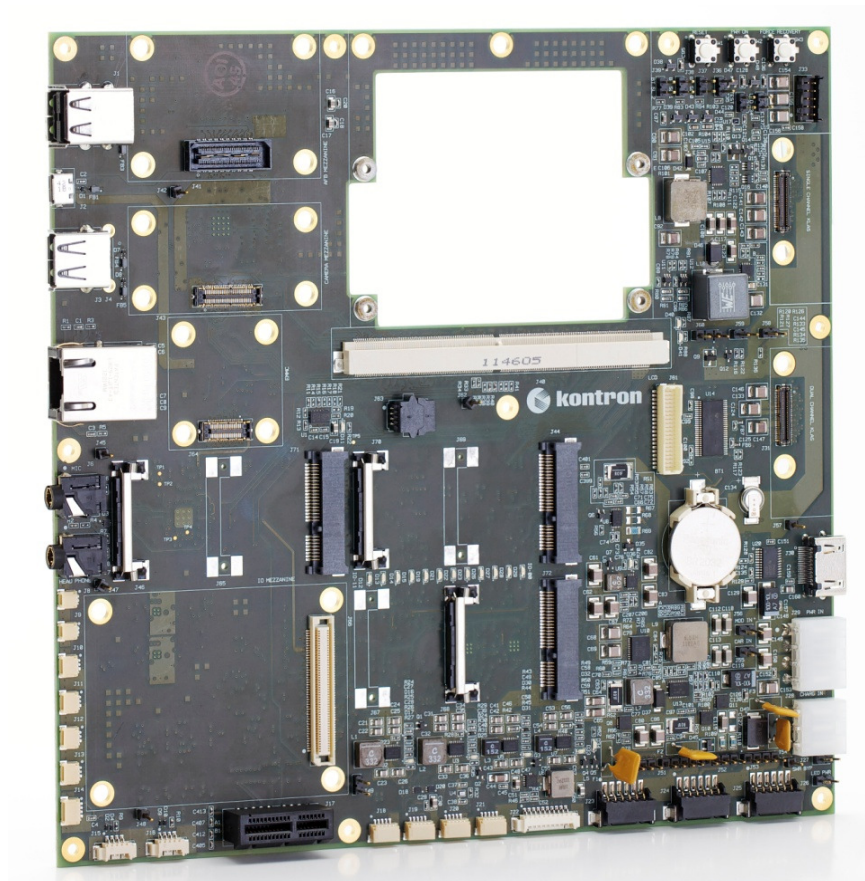

## SMARC Evaluation Carrier User Guide

Document revision 1.4

# » Table of Contents «

1	User Information .....	6
1.1	About This Document .....	6
1.2	Copyright Notice .....	6
1.3	Trademarks .....	6
1.4	Standards .....	6
1.5	Warranty .....	6
1.6	Technical Support .....	7
2	Introduction .....	8
2.1	General Introduction .....	8
2.2	SMARC Evaluation Carrier Goals .....	8
2.3	User Cautions .....	8
2.4	Feature Set Overview .....	8
2.5	Document and Standards References .....	9
2.5.1	External Industry Standard Documents .....	9
2.5.2	Kontron Documents .....	10
3	Block Diagrams .....	11
4	Layout Diagrams .....	14
5	Connectors – Cabled Interfaces .....	17
5.1	USB Connectors .....	17
5.1.1	J1 – USB Hub Connections .....	17
5.1.2	J2 – USB OTG Module Connection .....	17
5.1.3	J3 – J4 – USB Module Connection .....	17
5.2	Gigabit Ethernet .....	17
5.2.1	J5 – GBE RJ45 .....	17
5.3	Audio .....	18
5.3.1	J6 – Mic In .....	18
5.3.2	J7 – Headphone Out .....	18
5.3.3	J8 – Amplified Differential Audio Out, Left .....	19
5.3.4	J9 – Amplified Differential Audio Out, Right .....	19
5.3.5	J10 – Differential Microphone In .....	19
5.3.6	J11 – Line Level Audio Out .....	20
5.3.7	J12 – Digital Microphone In .....	20

5.3.8	J13 - Line Level Audio .....	20
5.3.9	J14 - SPDIF .....	20
5.4	CAN Bus .....	21
5.4.1	J15 - CAN0 .....	21
5.4.2	J16 - CAN1 .....	21
5.5	Asynchronous Serial Ports .....	22
5.5.1	General .....	22
5.5.2	J18 - SER2 .....	22
5.5.3	J19 - SER3 .....	22
5.5.4	J20 - SER0 .....	23
5.5.5	J21 - SER1 .....	23
5.6	Battery and Power Related Connectors and Jumpers .....	24
5.6.1	J22 - Battery Management Connector .....	24
5.6.2	J23 - J25 Battery Connectors .....	24
5.6.3	J28 Charger Input .....	25
5.7	Bench Power Supply .....	25
5.8	HDMI Connection .....	26
5.9	Parallel LCD .....	26
5.10	Auxiliary Backlight Power .....	28
5.10.1	J33 Auxiliary Backlight Power .....	28
6	Connectors - Standard Mezzanines, Slots and Sockets .....	29
6.1	mSATA Site .....	29
6.2	miniPCIe Connectors .....	29
6.3	PCIe x 1 Slot .....	29
6.4	SPI Socket .....	29
6.5	SD Card Slot .....	30
6.6	Micro SIM Site .....	30
6.7	RTC Battery Clip .....	30
6.8	SMARC Module Connector .....	30
7	Jumpers .....	32
7.1	Jumper J34 - LID# .....	32
7.2	Jumper J35 - TEST# .....	32
7.3	Jumpers J37, J38 and J39 - Boot Select .....	32
7.4	Jumper J36 - LVDS Panel Color Depth - Module LVDS .....	33
7.5	Jumper J49 - SD Card WP .....	33

7.6	Jumper J58 - LVDS Panel Color Depth - Carrier LVDS.....	33
7.7	Jumper J59 - Carrier Dual Channel LVDS Clock Edge.....	34
7.8	Jumper J51 and J53 - Battery Select - Power Paths.....	34
7.9	Jumpers J50 and J52 - Battery Select - Thermistor Paths.....	34
7.10	Jumpers J55 and J56 - Input Power Path.....	35
7.11	Jumper J27 - Step-Down Switcher Disable.....	36
7.12	Jumpers J75 & J85.....	36
7.13	Jumper J78 LVDS Voltage Output Level Select.....	36
7.14	Jumper J79 Single/Dual Channel LVDS Select.....	37
7.15	Jumper J81 LVDS Display Data Clocking.....	37
7.16	Jumper J82 LVDS Display Bit Mode Select.....	37
7.17	Jumper J83 Parallel LCD Voltage.....	37
7.18	Jumper J26 LED Power Source.....	38
8	Push Button Switches .....	39
8.1	SW1 Reset Switch.....	39
8.2	SW2 Power On Switch.....	39
8.3	SW3 Force Recovery Switch.....	39
9	LEDs .....	40
10	KLAS (Kontron LVDS Adapter System) Connections .....	41
11	I/O Mezzanine .....	47
12	MMC Mezzanine .....	52
13	Camera Mezzanine .....	56
14	AFB Mezzanine .....	60
15	I2C Buses and Devices .....	63
15.1	I2C Bus Summary.....	63
15.2	I2C Bus Power Domains.....	65
15.3	I2C PM Bus I/O Expanders.....	65
15.4	I2C GP Bus I/O Expanders.....	66
16	I2S Buses and Devices .....	69
16.1	I2S0.....	69
16.2	I2S1.....	69
16.3	I2S2.....	70
17	Power Architecture .....	71
17.1	Block Diagram Discussion.....	71
17.2	Figure 17 Power Architecture.....	72

18 Mechanical and Environmental Parameters .....	73
18.1 Mechanical Outline .....	73
18.2 Standoffs and Screw Hardware .....	74
18.3 Shock and Vibration .....	74
18.4 Thermal Environment .....	75
18.5 Humidity .....	75
18.6 RoHS Compliance .....	75
19 Appendix A: Connector Mating Part Number Information .....	76
20 Appendix B: Assembly Part Numbers .....	80
21 Appendix C: Document Revision History .....	82

## » Table of Figures «

Figure 1. System Block Diagram .....	12
Figure 2. Input Power Path Block Diagram .....	13
Figure 3. Carrier Top-side Connectors and Jumpers .....	14
Figure 4. Carrier Bottom-side Connectors .....	15
Figure 5. Carrier Top-side LEDs .....	16
Figure 6. Ethernet LEDs .....	18
Figure 7. KLAS Board 34mm x 18mm .....	41
Figure 8. KLAS Board 43mm x 18mm .....	42
Figure 9. KLAS Board 34mm x 18mm Outline .....	44
Figure 10. KLAS Board 43mm x 18mm Outline .....	45
Figure 11. I/O Mezzanine Card Outline .....	49
Figure 12. eMMC Mezzanine Card .....	53
Figure 13. eMMC Mezzanine Card Outline .....	54
Figure 14. Camera Mezzanine Card Outline .....	58
Figure 15. AFB Mezzanine Card Outline .....	61
Figure 16. I2S0 Switches .....	69
Figure 17. Power Architecture .....	72
Figure 18. Mechanical Outline .....	74

# 1 User Information

## 1.1 About This Document

This document provides information about products from Kontron and/or its subsidiaries. No warranty of suitability, purpose, or fitness is implied. While every attempt has been made to ensure that the information in this document is accurate, the information contained within is supplied "as-is" and it is subject to change without notice.

For the circuits, descriptions and tables indicated, Kontron assumes no responsibility as far as patents or other rights of third parties are concerned.

## 1.2 Copyright Notice

Copyright © 2012 Kontron America Inc.

All rights reserved. No part of this document may be reproduced, transmitted, transcribed, stored in a retrieval system, or translated into any language or computer language, in any form or by any means (electronic, mechanical, photocopying, recording, or otherwise), without the express written permission from Kontron.

## 1.3 Trademarks

The following lists the trademarks of components used in this board.

- » NVidia, Tegra, Sitara, ARM and all other products and trademarks mentioned in this manual are trademarks of their respective owners.

## 1.4 Standards

Kontron is certified to ISO 9000 Quality Standards.

## 1.5 Warranty

This Kontron product is warranted against defects in material and workmanship for the warranty period from the date of shipment. During the warranty period, Kontron will at its discretion decide to repair or replace defective products.

Within the warranty period, the repair of products is free of charge as long as warranty conditions are observed.

The warranty does not apply to defects resulting from improper or inadequate maintenance or handling by the buyer, unauthorized modification or misuse,

operation outside of the product's environmental specifications or improper installation or maintenance.

Kontron will not be responsible for any defects or damages to other products not supplied by Kontron that are caused by a faulty Kontron product.

## 1.6 Technical Support

Technicians and engineers from Kontron and/or its subsidiaries are available for technical support. We are committed to making our product easy to use and will help you use our products in your systems.

Please consult our website at <http://www.kontron.com/support> for the latest product documentation, utilities, drivers and support contacts. Consult our customer section <http://emdcustomersection.kontron.com/> for the latest software downloads, Product Change Notifications and additional tools and software. In any case you can always contact your board supplier for technical support.

## 2 Introduction

### 2.1 General Introduction

This document serves as a user manual and technical reference for the Kontron SMARC Evaluation Baseboard. The manual is intended for use by engineering personnel working with SMARC systems.

### 2.2 SMARC Evaluation Carrier Goals

The SMARC Evaluation Carrier is intended to serve multiple needs:

- » SMARC Module bring-up platform for hardware and software development.
- » Module validation platform.
- » Customer evaluation platform.
- » Customer design reference.
- » Manufacturing test platform.
- » Flexible prototyping vehicle (facilitated by multiple mezzanines).

### 2.3 User Cautions

**Caution!** The SMARC Evaluation Carrier is ESD sensitive equipment. Users must observe precautions for handling electrostatic discharge sensitive devices.

**Caution!** The SMARC Evaluation Carrier is a platform for Engineering evaluation and development. It is not a piece of consumer electronics.

**Caution!** There are jumper settings for power options, detailed in sections below, which are potentially hazardous if used incorrectly.

### 2.4 Feature Set Overview

- » SMARC specification compliant.
- » 210mm x 200mm form factor.
- » Accepts 82mm x 50mm and 82mm x 80mm SMARC Modules.
- » Accepts 1.8V SMARC V\_IO and 3.3V V\_IO.
- » Module LVDS KLAS (Kontron LVDS Adapter System) port.
- » HDMI port.
- » Parallel LCD port.
- » Carrier LVDS KLAS Adapter - 24 bit color packing, single and dual channel LVDS.
- » LED Backlight support - up to 31.9V.
- » USB OTG micro AB connector - direct from SMARC.



- » USB R/A Type A connector - direct from SMARC.
- » USB 7 port hub.
- » SATA MO-300 site.
- » Mini-PCIe sites (2) with shared SIM slot.
- » PCIe slot.
- » GbE port with integrated magnetics.
- » On-board I2S Audio Codec.
- » RS232 support for all 4 SMARC serial ports.
- » CAN Bus support (2).
- » Micro SD Card slot.
- » eMMC Mezzanine site.
- » Micro SD Card slot.
- » Camera Mezzanine site.
- » AFB (Alternate Function Block) site.
- » I/O Mezzanine site.
- » RTC backup power sources - Lithium coin cell socket and SuperCap option.
- » On-board accelerometer.
- » SIM card support.
- » Lab bench power input option - 3.0V to 5.25V input voltage range.
- » Support for Li-Ion batteries and on-board charging circuit.
- » Loop-back features for test on selected interfaces.
- » Carrier cutout allows access to back side of Module for Module debug.

## 2.5 Document and Standards References

### 2.5.1 External Industry Standard Documents

- » **CAN** ("**Controller Area Network**") Bus Standards - ISO 11898, ISO 11992, SAE J2411.
- » **CSI-2** (**Camera Serial Interface version 2**) The CSI-2 standard is owned and maintained by the MIPI Alliance ("Mobile Industry Processor Alliance") ([www.mipi.org](http://www.mipi.org)).
- » **eMMC** ("**Embedded Multi-Media Card**") the eMMC electrical standard is defined by JEDEC JESD84-B45 and the mechanical standard by JESD84-C44 ([www.jedec.org](http://www.jedec.org)).
- » **GBE MDI** ("**Gigabit Ethernet Medium Dependent Interface**") defined by IEEE 802.3. The 1000Base-T operation over copper twisted pair cabling defined by IEEE 802.3ab ([www.ieee.org](http://www.ieee.org)).
- » **HDMI Specification**, Version 1.3a, November 10, 2006 © Hitachi and other companies ([www.hdmi.org](http://www.hdmi.org)).

- » **The I2C Specification**, Version 2.1, January 2000, Philips Semiconductor (now NXP) ([www.nxp.com](http://www.nxp.com)).
- » **I2S Bus Specification**, Feb. 1986 and Revised June 5, 1996, Philips Semiconductor (now NXP) ([www.nxp.com](http://www.nxp.com)).
- » **JEDEC MO-300 (mSATA)** defines the physical form factor of the mSATA format ([www.jedec.org](http://www.jedec.org)). The electrical connections are defined in the Serial ATA document.
- » **MXM3 Graphics Module Mobile PCI Express Module Electromechanical Specification**, Version 3.0, Revision 1.1, © 2009 NVidia Corporation ([www.mxm-sig.org](http://www.mxm-sig.org)).
- » **PICMG® EEPROM Embedded EEPROM Specification**, Rev. 1.0, August 2010 ([www.picmg.org](http://www.picmg.org)).
- » **PCI Express Specifications** ([www.pci-sig.org](http://www.pci-sig.org)).
- » **PCI Express Mini Card Electromechanical Specification Revision 2.0**, April 21, 2012, © PCI-SIG ([www.pci-sig.org](http://www.pci-sig.org)).
- » **RS-232** (EIA "Recommended Standard 232") this standard for asynchronous serial port data exchange dates from 1962. The original standard is hard to find. Many good descriptions of the standard can be found on-line, e.g. at Wikipedia, and in text books.
- » **Serial ATA Revision 3.1**, July 18, 2011, Gold Revision, © Serial ATA International Organization ([www.sata-io.org](http://www.sata-io.org)).
- » **SD Specifications Part 1 Physical Layer Simplified Specification**, Version 3.01, May 18, 2010, © 2010 SD Group and SD Card Association ("Secure Digital") ([www.sdcard.org](http://www.sdcard.org)).
- » **SPDIF (aka S/PDIF)** ("Sony Philips Digital Interface) - IEC 60958-3.
- » **SPI Bus** - "Serial Peripheral Interface" - de-facto serial interface standard defined by Motorola. A good description may be found on Wikipedia ([http://en.wikipedia.org/wiki/Serial\\_Peripheral\\_Interface\\_Bus](http://en.wikipedia.org/wiki/Serial_Peripheral_Interface_Bus)).
- » **USB Specifications** ([www.usb.org](http://www.usb.org)).

## 2.5.2 Kontron Documents

Some of the documents referenced below may require an NDA to be in place before delivery. Check with your Kontron contact.

- » **Ultra Low Power - Computer On Module Hardware Specification**, version 1.2 September 19, 2012. © Kontron America 2012.
- » **SMARC Evaluation Carrier (KARMA Eval Carrier)** Board Schematic, 501-146, latest revision.
- » **eMMC Mezzanine** Schematic, KAI 501-151, latest revision.
- » **KLAS** Schematic, Hyundai 1366 x 768 Single Ch. LVDS, KAI 501-162, latest revision.
- » **KLAS** Schematic, NEC 1280 x 768 Single Ch. LVDS, KAI 501-163, latest revision.

### 3 Block Diagrams

An overall system block diagram for the SMARC Evaluation Carrier is shown on the following page. The following color coding is used on the block diagram:

- » Industry standard wired I/O connectors are shown in orange.
- » Kontron defined wired I/O connectors are shown in dark red.
- » Industry standard mezzanine and slot format connectors are shown in blue.
- » Kontron defined mezzanine connectors are shown in green.
- » ICs on the board are shown in pale yellow.
- » Miscellaneous features (jumpers, switches) are shown in drab green.

"A picture is worth 1000 words". Much may be gleaned from this diagram:

- » How SMARC resources are used on the Evaluation Carrier.
- » What the major Evaluation Carrier Features are.
- » An indication of the power supply architecture.
- » An indication of the loop-back possibilities for test.

Block Diagram Color Key:

- Industry standard connectors for wired, off-board connections
- Industry standard connectors for mezzanine format connectors
- Kontron defined connectors wired, off-board connections
- Kontron defined connectors and mezzanines
- IC and IC subsystems
- Other features

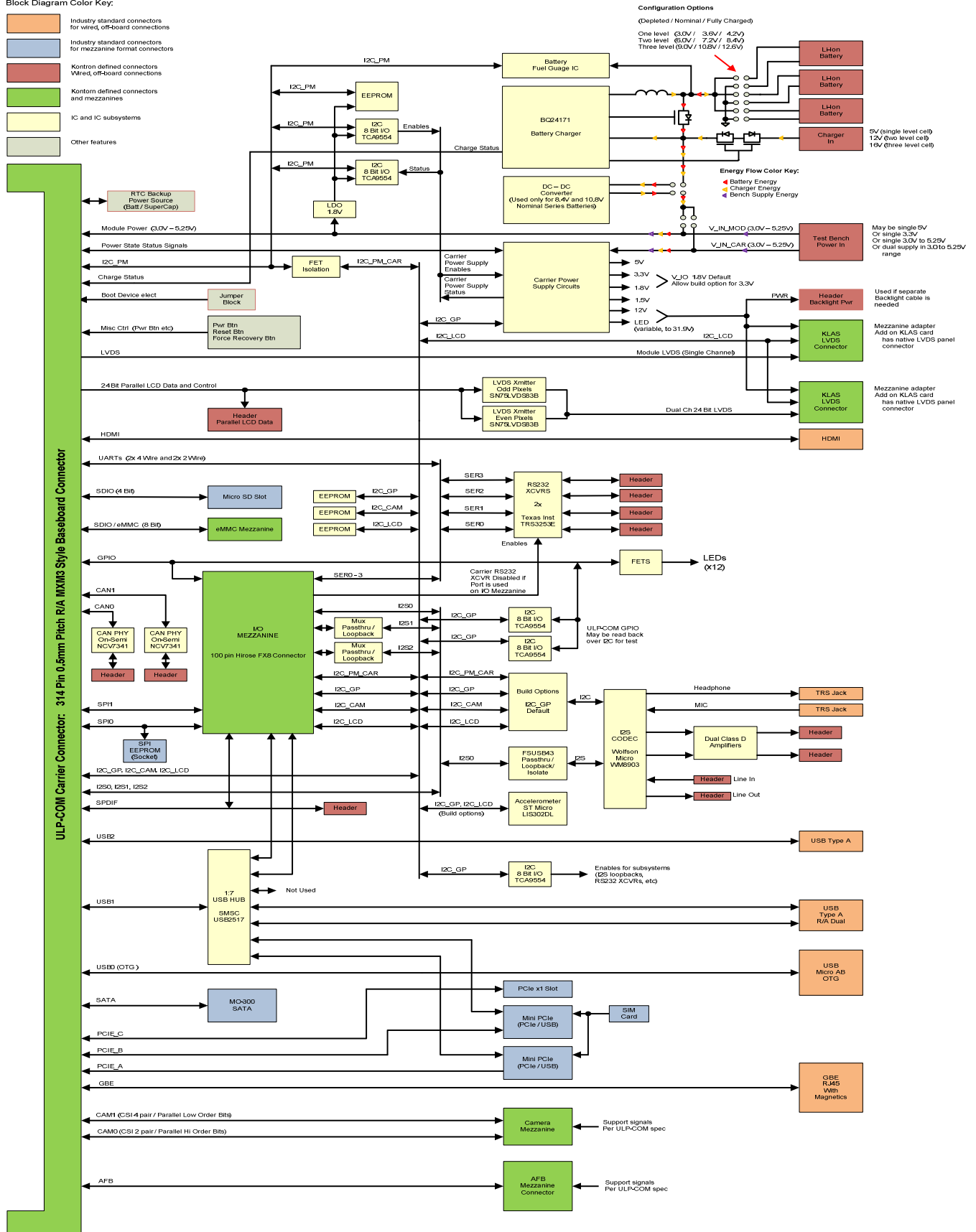

Figure 1. System Block Diagram

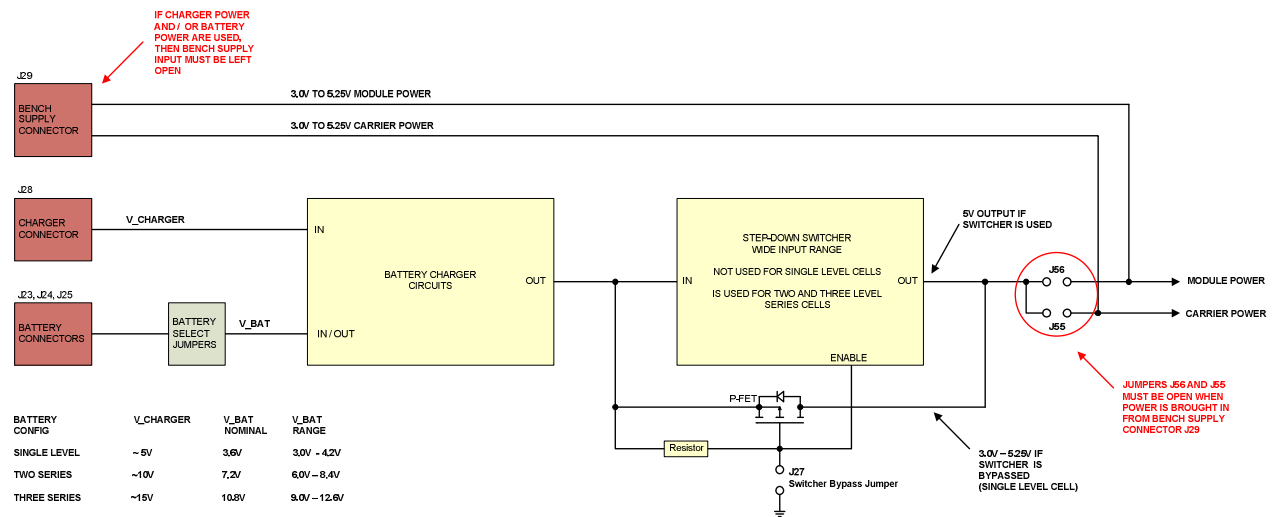

Figure 2. Input Power Path Block Diagram

**Caution!** There are two different ways to power the SMARC Evaluation Carrier and Module:

- » Bench Power Connector J29 (with jumpers J55 and J56 open).
- » Battery Charger / Battery Power Path - J28, J23, J24, J25 (with jumpers J55 and J56 closed; connector J29 open and not used).

**Caution!** These paths are **mutually exclusive** - you must use one or the other. More details on power options, battery options, etc. may be found in subsequent sections of this manual.

The Bench Supply connection, through J29, is convenient and easy to use. The two J29 power feeds may be wired together and can be sourced from a single 5V supply or used separately to allow Module and Carrier power measurements and voltage range validation.

**Caution!** If using the Bench Supply power path, jumpers J55 and J56 must be open.

## 4 Layout Diagrams

The following section shows the physical location of connectors, configuration jumpers and other important features on the SMARC Evaluation Carrier.

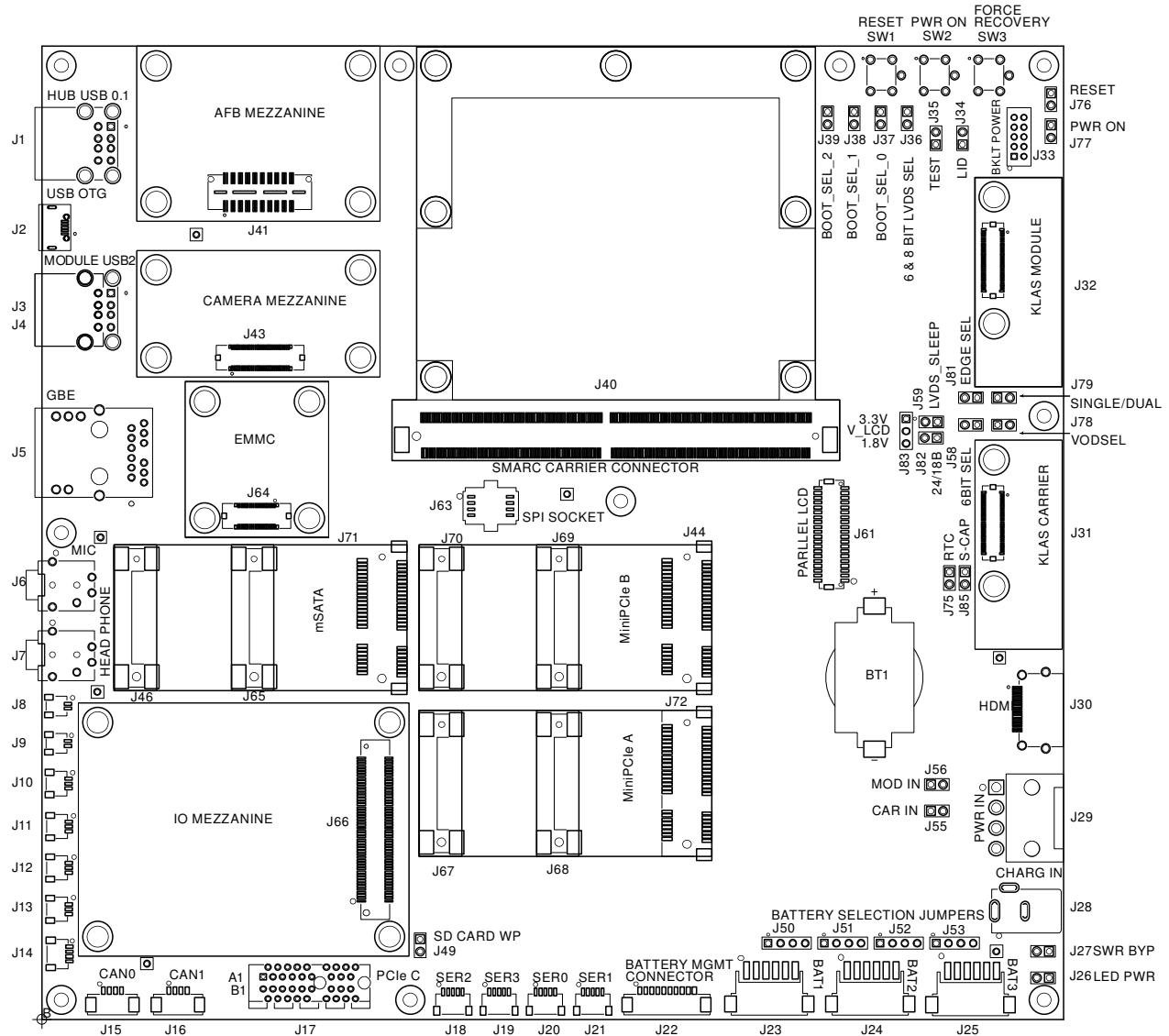

Figure 3. Carrier Top-side Connectors and Jumpers

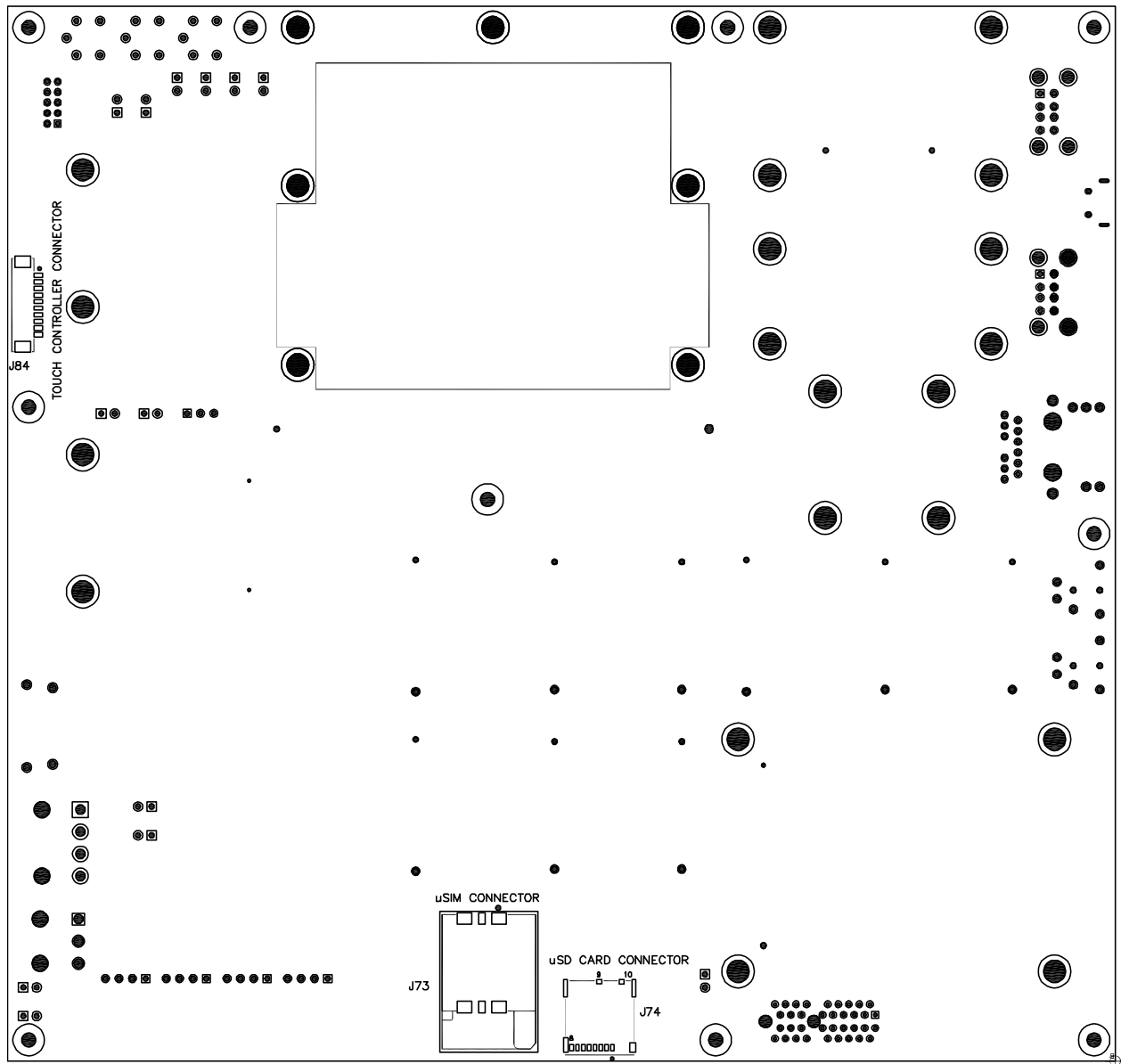

Figure 4. Carrier Bottom-side Connectors

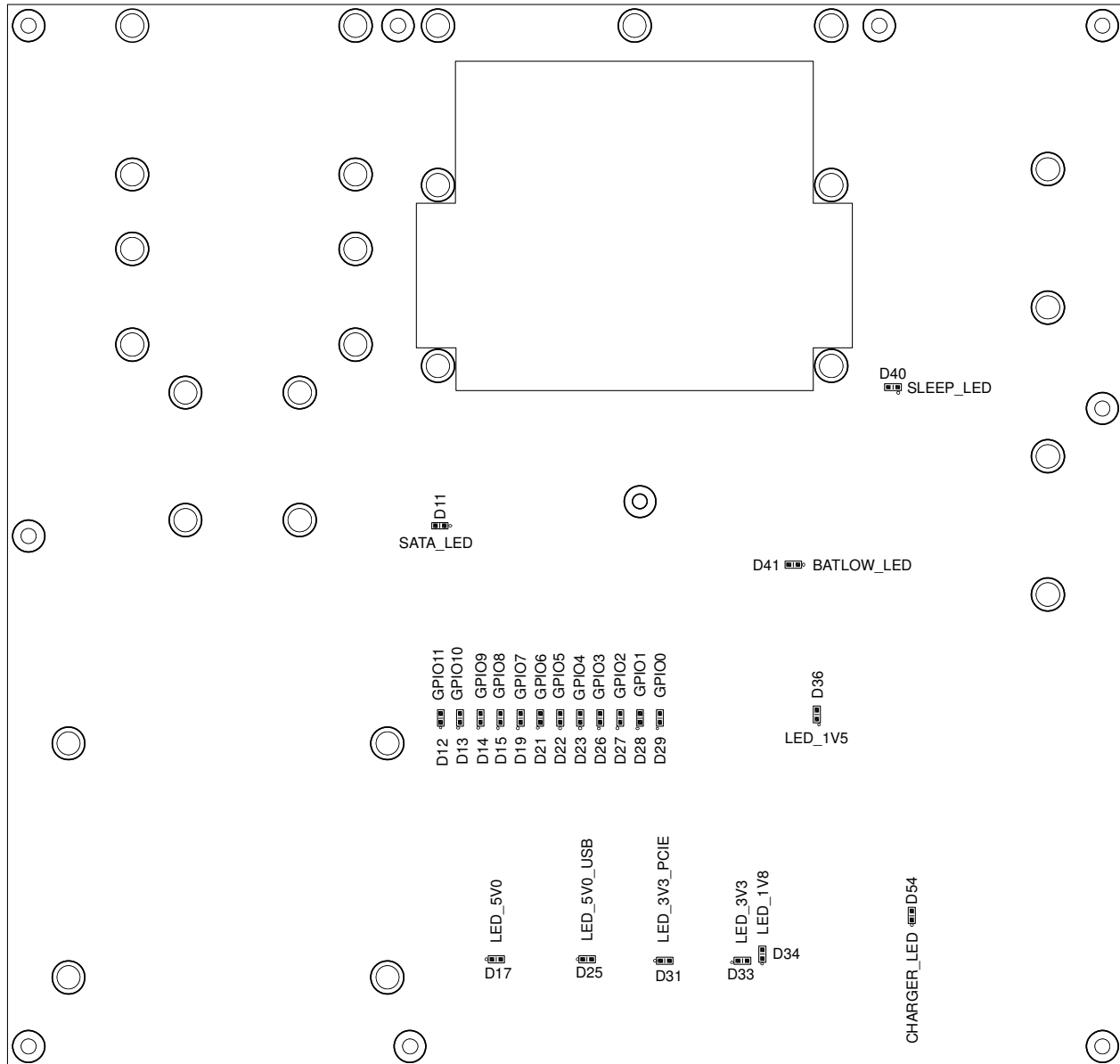

Figure 5. Carrier Top-side LEDs



## 5 Connectors – Cabled Interfaces

Wired connections to the SMARC Evaluation Carrier are described in this section. Information on mating connector part numbers is given in a table in **Section 19 Appendix A:** .

### 5.1 USB Connectors

#### 5.1.1 J1 – USB Hub Connections

Connector J1 implements an industry standard USB dual Type A host connection. The USB ports for J1 are ports that are downstream ports of the Evaluation Carrier's SMSC USB2517 hub. The hub upstream port is connected to the SMARC Module USB1 port.

#### 5.1.2 J2 – USB OTG Module Connection

Connector J2 implements an industry standard USB micro-AB connector. This small form factor flavor of USB connection is allowed to be either a client or a host, or can switch between being client or host. If the Module supports it, the J2 port may be USB OTG (On The Go) capable.

J2 is wired to the SMARC USB0 port, and the details of whether the port is client, host, or OTG capable depend on Module capabilities and how the Module is configured.

#### 5.1.3 J3 – J4 – USB Module Connection

J3 is an industry standard USB single Type A host connection. It is wired directly to the SMARC USB2 port.

There is a hole pattern at this connector site that allows a dual USB Type A host connector, J4, to be loaded instead of J3. If this is done, then the SMSC USB2517 USB Hub controller is not used, and the SMARC USB1 port is configured (via build options) to go to the upper connector slot in the J4 pattern. This is not the usual build, and exists only for certain special Module validation purposes.

### 5.2 Gigabit Ethernet

#### 5.2.1 J5 – GBE RJ45

J5 is an industry standard 8 pin RJ45 jack for use with 4-pair CAT5 cabling common for Gigabit Ethernet connections. The specific part used is the Bel-Fuse L829-1J1T-43 (Kontron SAP 1045-4258) or equivalent.

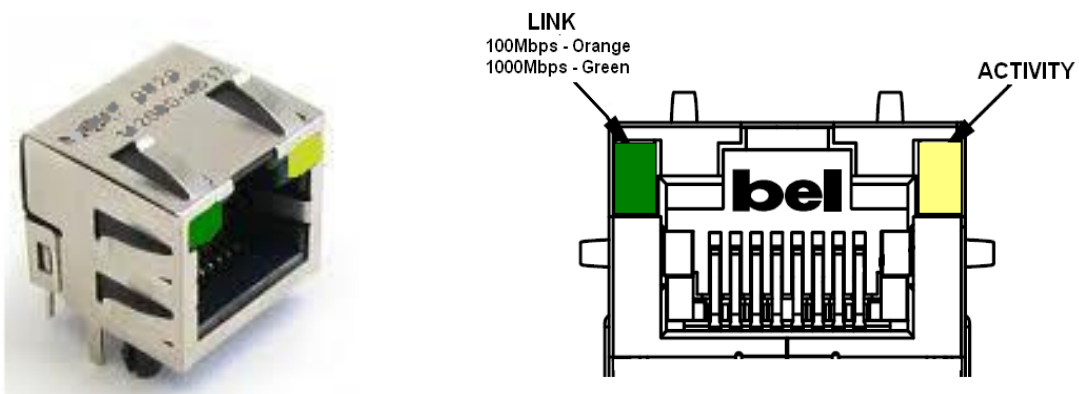

Figure 6. Ethernet LEDs

## 5.3 Audio

### 5.3.1 J6 – Mic In

Connector: CUI Inc SJ-43514-SMT, 3.5mm Audio Jack.

Pin Number	Pin Name	Signal	Notes
1	Sleeve	GND	
2	Tip	HP_MIC	Microphone In signal
3	Ring 1	HP_MIC	
4	Ring 2	GND	

### 5.3.2 J7 – Headphone Out

Connector: CUI Inc SJ-43514-SMT, 3.5mm Audio Jack.

Pin Number	Pin Name	Signal	Notes
1	Sleeve	GND	

2	Tip	HP_LEFT	
3	Ring 1	HP_RIGHT	
4	Ring 2	GND	

### 5.3.3 J8 – Amplified Differential Audio Out, Left

Connector: JST SM02B-SRSS-TB, 1mm pitch R/A SMD Header.

Pin Number	Signal	Notes
1	Amplified Audio Out Left +	
2	Amplified Audio Out Left -	

### 5.3.4 J9 – Amplified Differential Audio Out, Right

Connector: JST SM02B-SRSS-TB, 1mm pitch R/A SMD Header.

Pin Number	Signal	Notes
1	Amplified Audio Out Right +	
2	Amplified Audio Out Right -	

### 5.3.5 J10 – Differential Microphone In

Connector: JST SM03B-SRSS-TB, 1mm pitch R/A SMD Header.

Pin Number	Signal	Notes
1	MIC Right +	
2	MIC Right -	
3	Ground	

### 5.3.6 J11 - Line Level Audio Out

Connector: JST SM03B-SRSS-TB, 1mm pitch R/A SMD Header.

Pin Number	Signal	Notes
1	Line OUT Right	
2	Line OUT Left	
3	Ground	

### 5.3.7 J12 - Digital Microphone In

Connector: JST SM03B-SRSS-TB, 1mm pitch R/A SMD Header.

Pin Number	Signal	Notes
1	Digital MIC Data	
2	Digital MIC Clock	
3	Ground	

### 5.3.8 J13 - Line Level Audio

Connector: JST SM03B-SRSS-TB, 1mm pitch R/A SMD Header.

Pin Number	Signal	Notes
1	Line IN Right	
2	Line IN Left	
3	Ground	

### 5.3.9 J14 - SPDIF

Connector: JST SM04B-SRSS-TB, 1mm pitch R/A SMD Header.

Pin Number	Signal	Notes
------------	--------	-------

1	IO Power	1.8V or 3.3V
2	SPDIF Data Out	
3	SPDIF Data In	
4	Ground	

## 5.4 CAN Bus

### 5.4.1 J15 - CAN0

Connector: Molex 53261-0471, 1.25mm pitch R/A Header.

Pin Number	Signal	Notes
1	CAN 0 Dominant Low	
2	CAN0 Dominant High	
3	5V power	
4	Ground	

### 5.4.2 J16 - CAN1

Connector: Molex 53261-0471, 1.25mm pitch R/A Header.

Pin Number	Signal	Notes
1	CAN1 Dominant Low	
2	CAN1 Dominant High	
3	5V power	
4	Ground	

## 5.5 Asynchronous Serial Ports

### 5.5.1 General

The SMARC Evaluation Carrier supports the four serial ports defined in the SMARC specification. The Evaluation Carrier has EIA RS232 compliant signal levels and polarities. Per the SMARC specification, two of the four ports have RTS / CTS handshaking, and two have TX and RX data only, without handshaking.

The Evaluation Carrier runs SER0 and SER1 through one transceiver, and SER2 and SER3 through a 2<sup>nd</sup> transceiver. There are provisions that allow I/O Mezzanine card circuitry to disable the SER0/1 transceiver, and / or disable the SER2/3 transceiver. These provisions exist so that users may optionally take over SER0/1 or SER2/3 and use them in alternative ways on the I/O Mezzanine (to interface to a peripheral such as a GPS module or an RS485 transceiver).

### 5.5.2 J18 – SER2

Connector: JST SM05B-SRSS-TB, 1mm pitch R/A SMD header.

Pin Number	Signal	Notes
1	Serial port 2 - Receive Data	
2	Serial port 2 - Transmit Data	
3	Serial port 2 - Request to Send	
4	Serial port 2 - Clear to Send	
5	Ground	

### 5.5.3 J19 – SER3

Connector: JST SM05B-SRSS-TB, 1mm pitch R/A SMD header.

Pin Number	Signal	Notes
1	Serial port 3 - Receive Data	

2	Serial port 3 - Transmit Data	
3		Not used
4		Not used
5	Ground	

#### 5.5.4 J20 - SER0

Connector: JST SM05B-SRSS-TB, 1mm pitch R/A SMD header.

Pin Number	Signal	Notes
1	Serial port 0 - Receive Data	
2	Serial port 0 - Transmit Data	
3	Serial port 0 - Request to Send	
4	Serial port 0 - Clear to Send	
5	Ground	

#### 5.5.5 J21 - SER1

Connector: JST SM05B-SRSS-TB, 1mm pitch R/A SMD header.

Pin Number	Signal	Notes
1	Serial port 1 - Receive Data	
2	Serial port 1 - Transmit Data	
3		Not used
4		Not used
5	Ground	

## 5.6 Battery and Power Related Connectors and Jumpers

The SMARC Evaluation Carrier implements a flexible battery connection scheme, allowing single level single cells, parallel single level cells, two series cells and three series cells.

**Caution!** Moving between these combinations requires that the user pay close attention to the battery wiring details and the battery jumper settings. There are hazards in getting it wrong.

### 5.6.1 J22 – Battery Management Connector

This connector exists so that key battery management signals are available off-board to allow engineers to prototype an external battery charger circuit, separate from the charger circuit implemented on the Evaluation Carrier. In most cases, this connector is not needed and can be ignored.

Connector: Molex 53261-1071, 1.25mm pitch R/A SMD header.

Pin Number	PIN Name	Notes
1	CHARGER_PRSENT#	Charger Present indication from battery
3	CHARGING#	Charging indication from battery
5	BATLOW#	Battery Low indication from battery
7	I2C_PM_CK	I2C Clock
8	I2C_PM_DAT	I2C Data
2, 4, 10	NC	No Connect
6, 9	GND	Ground

### 5.6.2 J23 – J25 Battery Connectors

J23, J24 and J25 are slots for inserting Battery 1, Battery 2 and Battery 3 respectively.

All the three connectors have the same pin-out.

Connector: TE-Connectivity 2-292173-6, 2mm pitch R/A SMT Header.

Pin Number	Signal	Notes
1, 2	Battery Supply	



	Positive	
3	Battery Thermistor +	
4	Battery Thermistor -	
5,6	Battery Supply Negative	

### 5.6.3 J28 Charger Input

Connector: Kycon KLDHCX-0202-B      2.5mm Diameter DC Power Connector

Pin Number	Signal	Notes
1	Charger Input	Center Post
2	Ground	Sleeve
3	No Connect	

**Caution!** The charger voltage level depends on the battery configuration (single, dual or triple level cells - nominally 5V, 10V or 15V).

## 5.7 Bench Power Supply

The Evaluation Carrier may be powered by a lab bench supply over connector J29. This is the most common way that the SMARC Evaluation Carrier is used.

There are two power feeds to the Bench Supply: one for the Evaluation Carrier circuits, and one for the Module. This allows the Evaluation Carrier current and power consumption and the Module current and power consumption to be measured separately. The two feeds may be combined and powered from a single source if the user does not care about the separate measurements. The source(s) should be a DC supply in the 3.0 to 5.25V range.

Connector: Molex 39-30-3045, 4.2mm pitch R/A through-hole header.

Pin Number	Signal	Notes

1	Module Power	3.0V to 5.25V may be independent of Carrier power.
2	GND	
3	Carrier Power	3.0V to 5.25V may be independent of Carrier power.
4	GND	

**Caution!** When power is brought in through the J29 Bench Power Supply connector, then jumpers J56 and J57 must be open.

## 5.8 HDMI Connection

The SMARC Evaluation Carrier implements an industry standard HDMI connector.

## 5.9 Parallel LCD

The SMARC Evaluation Carrier brings the SMARC Module parallel LCD signals to a 40 pin 1mm pitch header that can be cabled to. The parallel LCD signals are also routed to a dual-channel LVDS transmitter on the Carrier, allowing dual channel LVDS to be realized.

The color mapping of the parallel LCD data bits are defined in the SMARC specification document.

The parallel LCD data signal level is, per the SMARC specification, at  $V_{IO}$ , which typically is 1.8V. The 40 pin LCD header has pins with 1.8V and 3.3V supply voltages for the panel. All signals listed below are at  $V_{IO}$  level.

There are no backlight supply voltages or control pins on the 40 pin connector. There is a separate connector, J33, for supplying voltages to the backlight.

Connector: JST BM40B-SRDS-A-G-TF, 1mm pitch 2 row (20x2) SMD vertical header.

Pin Number	Signal	Notes
1	LCD Data 0	BLU0 (LS bit)
2	LCD Data 1	BLU1
3	LCD Data 2	BLU2
4	LCD Data 3	BLU3
6	LCD Data 4	BLU4

7	LCD Data 5	BLU5
8	LCD Data 6	BLU6
9	LCD Data 7	BLU7 (MS bit)
11	LCD Data 8	GRN0 (LS bit)
12	LCD Data 9	GRN1
13	LCD Data 10	GRN2
14	LCD Data 11	GRN3
16	LCD Data 12	GRN4
17	LCD Data 13	GRN5
18	LCD Data 14	GRN6
19	LCD Data 15	GRN7 (MS bit)
21	LCD Data 16	RED0 (LS bit)
22	LCD Data 17	RED1
23	LCD Data 18	RED2
24	LCD Data 19	RED3
26	LCD Data 20	RED4
27	LCD Data 21	RED5
28	LCD Data 22	RED6
29	LCD Data 23	RED7 (MS bit)
31	Horizontal Sync	
32	Vertical Sync	
33	Display Enable	
34	Pixel clock	
38	Enable for panel VDD	
5,10,15, 20,25,30 ,35	GND	
36,37	3.3V	

39, 49	1.8V	
--------	------	--

## 5.10 Auxiliary Backlight Power

### 5.10.1 J33 Auxiliary Backlight Power

Connector: Hirose DF11-10DP-2DSA, 2mm pitch dual row (5x2) vertical header.

Pin Number	Signal	Notes
5	LCD_BKLT_EN	Backlight Enable V_IO signal level
6	LCD_BKLT_PWM	Backlight PWM V_IO signal level
1,3	5V	
7,9	12V	
2,4,6,8,10	GND	

## 6 Connectors – Standard Mezzanines, Slots and Sockets

Connector part number information is given in a table in **Section 19** Appendix A:

### 6.1 mSATA Site

The SMARC Evaluation Carrier implements a SATA port in the JEDEC MO-300 (mSATA) form factor at site J71. This form factor uses the same connector as mini-PCIe, but the electrical connections are different. Mini-PCIe cards will not be functional in site J71. If a mini-PCIe card is accidentally inserted, the chance of damage is remote but possible.

### 6.2 miniPCIe Connectors

Two miniPCIe sites are implemented on the SMARC Evaluation Carrier. The two sites use industry standard miniPCIe connector implementations, as defined in *PCI Express Mini Card Electromechanical Specification*. The Evaluation Carrier design allows full size or half-size miniPCIe configurations to be built.

Site J72 is referred to as the “miniPCIe A” site because it ties to SMARC Module PCIE\_A. This site is typically built in the half-size card configuration.

Site J44 is the “miniPCIe B” site, fed by SMARC Module PCIE\_B. This site is typically built in the full-size card configuration.

Both of the Evaluation Carrier miniPCIe sites have a USB connection as well as a PCIe connection. The USB interfaces are to the Evaluation Carrier 7 port USB hub chip.

The two miniPCIe sites share a connection to a microSIM card slot.

### 6.3 PCIe x 1 Slot

An industry standard PCIe x1 slot is implemented on the SMARC Evaluation Carrier. It is connected to the SMARC PCIE\_C port.

All SMARC Modules are expected to provide at least one PCIe port (Port A). Some will support two ports (A and B). Relatively few Modules support a 3<sup>rd</sup> port, so the SMARC PCIe x1 slot may be of limited use.

### 6.4 SPI Socket

The Evaluation Carrier has a “coffin style” zero insertion force socket for 8 pin SPI devices. The socket is Lotes ACA-SPI-004-T01, for SPI devices with a 5.4mm x 5.4mm body size, 1.27mm lead pitch and 8.2mm overall lead span.

The SPI device is powered by V<sub>IO</sub> on the Evaluation Carrier. The V<sub>IO</sub> voltage is usually 1.8V, determined by the Module.

A suitable SPI device for 1.8V I/O operation is the Winbond W25Q64DWSSIG (64 Mbits). Another one is Winbond W25Q16DWSSIG (16 Mbits).

## 6.5 SD Card Slot

An industry standard micro-SD Card slot is located on the back of the Eval Carrier, in position J74. It supports 3.3V SD cards.

Jumper J49 may be open to write-protect the card. To allow the card to be written to, leave J49 closed.

## 6.6 Micro SIM Site

The *PCI Express Mini Card Electromechanical Specification* defines connection pins for a SIM ("Subscriber Identity Module") card. In the PCI-SIG document, it is referred to as a UIM ("User Identity Module"). The SMARC Evaluation Carrier implements a micro-SIM slot at position J73, on the back of the Evaluation Carrier. The connector part used is a 6 pin 15mm x 12mm micro SIM connector, Molex 470230001.

## 6.7 RTC Battery Clip

A socket connector for a 20mm diameter 3V lithium coin cell battery is available on the Evaluation Carrier in position BT1. The connector socket used is Renata SMTU2032-LF. A suitable battery is Panasonic CR2032.

The battery '+' terminal is protected against charging (as required by safety regulations) by a series Schottky diode and a 1K resistor (R147). The 1K resistor feeds the SMARC VDD\_RTC pin (SMARC pin S147).

The Evaluation Carrier also has a 0.2F "SuperCap" that may be loaded to supply a backup voltage to the SMARC VDD\_RTC, instead of the battery. The SuperCap is at position C134, and connects to the SMARC VDD\_RTC pin through a 1K resistor, at position R151.

## 6.8 SMARC Module Connector

The SMARC Module is supported on J40. This is a 314 pin MXM3 style connector. The J40 pin-out conforms to the SMARC Module specification. The Evaluation Carrier supports Module I/O = 1.8V.

The MXM3 style connector used on the Evaluation Carrier is a low profile part, with a board-to-board spacing of 1.5mm. The Evaluation Carrier has captive M2.5 threaded standoffs in the SMARC mounting hole positions. The standoffs accept M2.5 screws, inserted from above, through the Module holes.

Both 82mm x 50mm and 82mm x 80mm format SMARC Modules may be used with the Evaluation Carrier. The Evaluation Carrier PCB has a cut-out allowing access to the back side of the SMARC Module for test and debug.

## 7 Jumpers

### 7.1 Jumper J34 - LID#

J34 is used to simulate LID-open and LID-closed condition, for test and development.

Jumper	Position	Function
J34	Inserted	Simulates LID closed condition
	Not inserted	Simulates LID open condition

### 7.2 Jumper J35 - TEST#

J35 is used for Module specific test purposes. In normal operation, this jumper should be open.

Jumper	Position	Function
J35	Inserted	Module specific test - check Module documentation
	Not inserted	Normal operation

### 7.3 Jumpers J37, J38 and J39 - Boot Select

J37, J38 and J39 are used to select the boot device. The following table is transcribed from the SMARC Module specification. Some Modules may not support all options; refer to the Module documentation. The meaning of "boot" may vary as well - check the Module documentation.

J39	J38	J37	Boot Device
Inserted	Inserted	Inserted	Carrier SATA
Inserted	Inserted	Not inserted	Carrier SD Card
Inserted	Not inserted	Inserted	Carrier eMMC Flash
Inserted	Not inserted	Not inserted	Carrier SPI
Not inserted	Inserted	Inserted	Module device (NAND, NOR) - vendor specific



Not inserted	Inserted	Not inserted	Remote boot (GBE, serial) - vendor specific
Not inserted	Not inserted	Inserted	Module eMMC Flash
Not inserted	Not inserted	Not inserted	Module SPI

#### 7.4 Jumper J36 - LVDS Panel Color Depth - Module LVDS

Jumpers J36 is used for selecting the color depth of the Module LVDS display. Most Modules will use 6 bit color packing on the Module LVDS, and J36 should be inserted. This jumper has an effect only when the LVDS display in use has the corresponding 6 bit / 8 bit color pack selection capability.

Jumper	Position	Function
J36	Inserted	Sets 6 bit per color packing on the display (if the display supports this feature)
	Not inserted	Sets 8 bit per color packing on the display (if the display supports this feature)

#### 7.5 Jumper J49 - SD Card WP

J49 is used to enable or disable the SDIO Write Protect.

Jumper	Position	Function
J49	Inserted	Write access enabled for the SD card
	Not inserted	SD card is write protected

#### 7.6 Jumper J58 - LVDS Panel Color Depth - Carrier LVDS

Jumper	Position	Function
J58	Inserted	Sets 6 bit per color packing on the display (if the display supports this feature)
	Not inserted	Sets 8 bit per color packing on the display (if the display supports this feature)

## 7.7 Jumper J59 – Carrier Dual Channel LVDS Clock Edge

A 24 bit dual channel LVDS implementation comprises 10 differential pairs: 4 pairs for odd pixel and control data; 1 pair for the LVDS clock for the odd data; 4 pairs for the even pixel data and control data, and 1 pair for the even LVDS clock.

The SMARC Evaluation Carrier uses one LVDS transmitter for even pixel signals (U14) and another LVDS transmitter for odd pixel signals (U21). Data is clocked into the pair of Carrier Board LVDS transmitters by LCD\_DUAL\_PCK.

J59 is used for selecting the active clock edge for the LVDS transmitters to latch data on as shown below:

Jumper	Position	Function
J59	Inserted	U14 latches on rising clock edge and U21 latches on falling clock edge
	Not inserted	U21 latches on rising clock edge and U14 latches on falling clock edge

## 7.8 Jumper J51 and J53 – Battery Select – Power Paths

Three batteries (BAT1, BAT2 and BAT3) are provided on the board and the user can realize various combinations mentioned in the table below based on the position of the jumpers J51 and J53.

Function	Inserted	Not inserted
3.6V Li-Ion (1 cell, BAT1)	J51 (Pin 3-4)	All others
3.6V Li-Ion (2 cells, parallel, BAT1 & BAT2)	J51 (Pin 1-2) J51 (Pin 3-4) J53 (Pin 3-4)	All others
7.2V Li-Ion (2 cells, series, BAT1 & BAT2)	J51 (Pin 2-3) J53 (Pin 3-4)	All others
10.8V Li-Ion (3 cells, series BAT1, BAT2, & BAT3)	J51 (Pin 2-3) J53 (Pin 2-3)	All others

## 7.9 Jumpers J50 and J52 – Battery Select – Thermistor Paths

Corresponding to the chosen battery combination, battery pack thermistor selection is done using jumpers J50 and J52 as per the table below:

Function	Inserted	Not inserted
3.6V Li-Ion (1 cell, BAT1)	J50 (Pin 3-4)	All others
3.6V Li-Ion (2 cells, parallel, BAT1 & BAT2)	J50 (Pin 1-2) J50 (Pin 3-4) J52 (Pin 3-4)	All others
7.2V Li-Ion (2 cells, series, BAT1 & BAT2)	J50 (Pin 2-3) J52 (Pin 3-4)	All others
10.8V Li-Ion (3 cells, series, BAT1, BAT2, & BAT3)	J50 (Pin 2-3) J52 (Pin 2-3)	All others

## 7.10 Jumpers J55 and J56 - Input Power Path

Jumpers J55 and J56 connect the Evaluation Carrier battery charging subsystem to the rest of the Evaluation Carrier. Refer to

**Figure 2. Input Power Path Block** Diagram

for an illustration. There are two different ways to power the SMARC Evaluation Carrier:

- » Bench Power Connector J29 (with jumpers J55 and J56 open).
- » Battery Charger / Battery Power Path - J28, J23, J24, J25 (with jumpers J55 and J56 closed; connector J29 open and not used).

**Caution!** These paths are mutually exclusive - you must use one or the other.

**Caution!** The Bench Supply connection, through J29, is convenient and easy to use. The two J29 power feeds may be wired together and can be sourced from a single 5V supply. **If using the Bench Supply power path, jumpers J55 and J56 must be open.**

## 7.11 Jumper J27 - Step-Down Switcher Disable

J27 is used to enable or disable and bypass the step-down switcher in the Battery Charger subsystem. Refer to

**Figure 2. Input Power Path Block** Diagram

for an illustration.

For single level battery cells (3.6V nominal battery voltage), the switcher should be disabled. For two level and three level cells, the switcher should be enabled.

Jumper	Position	Function
J27	Inserted	Disables step-down switcher in Battery Charger system.
	Not inserted	Switcher enabled

## 7.12 Jumpers J75 & J85

The RTC power well can be powered via a CMOS battery, or a 220mF super-cap.

Jumper	Position	Function
J75	Inserted	RTC power well powered by CMOS battery
J85	Not inserted	RTC power well powered by super-cap

## 7.13 Jumper J78 LVDS Voltage Output Level Select

J78 can be used to select a lower voltage output on the LVDS signals going to J31.

Jumper	Position	Function
J78	Inserted	Low peak-to-peak voltage swing on LVDS
	Not inserted	Normal peak-to-peak voltage swing on LVDS

## 7.14 Jumper J79 Single/Dual Channel LVDS Select

J79 is used to set the LVDS display output to either single, or dual channel LVDS on connector J31.

Jumper	Position	Function
J79	Inserted	Single channel output
	Not inserted	Dual channel output

## 7.15 Jumper J81 LVDS Display Data Clocking

J81 defines whether data is clocked into the LVDS serializer (U63) on the rising edge, or falling edge of the pixel clock.

Jumper	Position	Function
J81	Inserted	Data clocked on falling edge
	Not inserted	Data clocked on rising edge

## 7.16 Jumper J82 LVDS Display Bit Mode Select

J82 sets the LVDS data going to connector J31 to either 18 bit, or 24bit mode.

Jumper	Position	Function
J82	Inserted	24 Bit Mode
	Not inserted	18 Bit Mode

## 7.17 Jumper J83 Parallel LCD Voltage

The carrier can power either a 3.3V Parallel LCD, or 1.8V Parallel LCD via connector J61. Which voltage is applied is dependent on the position of the jumper installed at J83.

Jumper	Position	Function
J83	Pin 1-2	Enables 3.3V to Parallel LCD connector J61
	Pin 2-3	Enables 1.8V to Parallel LCD connector J61

## 7.18 Jumper J26 LED Power Source

The LED power source can be disconnected by removing jumper J26. This can be important when trying to minimize power. The combined power consumption of all the LEDs, if they are all on, can be over 0.5W.

Jumper	Position	Function
J26	Inserted	LEDs are powered
	Not inserted	LED power is cut off

## 8 Push Button Switches

### 8.1 SW1 Reset Switch

Switch SW1, if pressed, forces the SMARC Module RESET\_IN# (Module connector J40 pin P127) signal to GND. It also forces the I/O Module J66 pin 66 to GND.

The switch does nothing else, and does **not** issue a general reset signal to the Evaluation Carrier. It is just a signal to the Module that the user is requesting a reset. The Module processes this and the Module in turn may force the SMARC RESET\_OUT# line low (Module connector J40 pin P127).

There is no de-bouncing of SW1 on the Eval Carrier. This happens on the Module. If the SW1 switch is not being pressed, then the RESET\_IN# line floats on the Carrier and is pulled up on the Module.

### 8.2 SW2 Power On Switch

Switch SW2 is the power button input to the SMARC module from the carrier board (POWER\_BTN#: pin P128 of J40). If pressed, it forces POWER\_BTN# signal to GND.

The switch only powers ON the module, it does not power the carrier. The carrier does not have a pull up on this signal and remains in the float state when the switch is released. The signal should be pulled up in the module.

De-bouncing circuitry is not provided for SW2 in the carrier.

### 8.3 SW3 Force Recovery Switch

Switch SW3 gives the Force recovery input to the SMARC module (FORCE\_RECOV# Pin S155 of J40). If pressed, it asserts FORCE\_RECOV# signal to GND.

Low on this pin allows non-protected segments of Module boot device to be rewritten / restored from an external USB Host on Module USB0. For SOCs that do not implement USB based Force Recovery functions, a low on the Module FORCE\_RECOV# pin may invoke the SOC native Force Recovery mode - such as over a Serial Port.

If the switch is not being pressed, then the FORCE\_RECOV# line floats on the Carrier and is pulled up on the Module. De-bouncing circuitry is not provided for SW3 in the carrier.

## 9 LEDs

There are 20 status LEDs on the Evaluation Carrier.

Location	Signal	Function
D11	SATA Activity	Blinks on SATA activity
D12	GPIO11	GPIO is high if LED is lit
D13	GPIO10	GPIO is high if LED is lit
D14	GPIO09	GPIO is high if LED is lit
D15	GPIO08	GPIO is high if LED is lit
D19	GPIO07	GPIO is high if LED is lit
D21	GPIO06	GPIO is high if LED is lit
D22	GPIO05	GPIO is high if LED is lit
D23	GPIO04	GPIO is high if LED is lit
D26	GPIO03	GPIO is high if LED is lit
D27	GPIO02	GPIO is high if LED is lit
D28	GPIO01	GPIO is high if LED is lit
D29	GPIO00	GPIO is high if LED is lit
D17	5V	Indicates Carrier 5V rail is up
D25	5V USB	Indicates Carrier 5V_USB rail is up
D31	3.3V PCIe	Indicates Carrier 3.3V PCIe rail is up
D33	3.3V	Indicates Carrier 3.3V rail is up
D40	SLEEP	Indicates unit is in sleep state
D41	BATLOW	Indicates low battery state
D54	Bat Charging	On bottom of PCB on Rev A (an error)

The LED power source can be disconnected by removing jumper J26. This can be important when trying to minimize power. The combined power consumption of all the LEDs, if they are all on, can be over 0.5W.



## 10 KLAS (Kontron LVDS Adapter System) Connections

The Evaluation Carrier features two Kontron LVDS Adapter System mezzanine boards: one for the Module LVDS, and one for the LVDS path that is created on the Evaluation Carrier from the Module parallel LCD bus. This later LVDS path is referred to as the "Carrier LVDS".

The purpose of the KLAS boards is to allow adaptation of the Evaluation Carrier LVDS interfaces to various displays that is mechanically robust and electrically preserves excellent signal integrity. Modern LVDS displays come with various connector interfaces, including more than a few that use very fine pitch FFC (Flat Flexible Cables). The only good way to interface to displays with FFC connections is to have the correct mating connector for the FFC on the source board. Other displays use various discrete wire connectors. In order to not lock the Evaluation Carrier down to a single LVDS display, the KLAS concept was developed. KLAS is a small transition board that is mounted to the Evaluation Carrier. The KLAS transition board mounts to the Evaluation Carrier and has a display specific connector on it. It may also have an EDID EEPROM and display -specific strap options on board.

KLAS boards come in two sizes: 34mm x 18mm and 43mm x 18mm. The larger size allows for larger (usually discrete wire) display connectors, and also makes it easier to fit in an EDID EEPROM. The two sizes have a common hole pattern for M2.5 mounting hardware. The two KLAS board sizes are illustrated in the two figures on the following pages. Designers should plan for the larger KLAS size, and then the smaller one will always fit as well.

The following figure shows some images of a typical KLAS board. This one is a 34mm x 18mm board with a connector for a 0.3mm pitch FFC for a Hyundai flat panel, evident in the right hand image. The bottom of the KLAS board is shown in the image at left. This connector mates with the Evaluation Carrier.

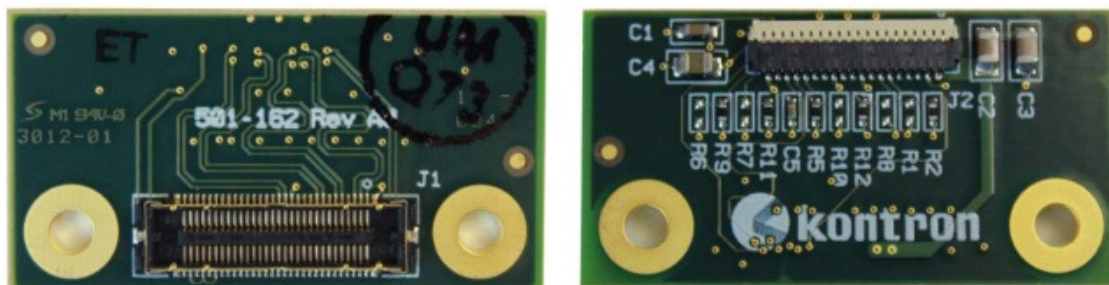

Figure 7. KLAS Board 34mm x 18mm

A slightly larger format KLAS board is shown in the image below. The board is extended to the right, relative to the smaller KLAS board, allowing room for larger display connectors. There is also room for an EDID serial EEPROM. The mounting holes are compatible between the two KLAS board sizes. Some of the various passives set certain display specific straps - for example, on the display used with this particular KLAS board allows the display image to be rotated 180 degrees, depending on a display pin strap. The KLAS board can be configured to take advantage of that feature.



**Figure 8. KLAS Board 43mm x 18mm**

Per the SMARC specification, the Module LVDS path is single-channel LVDS only. The physical interface is capable of 18 bit (4 LVDS pair) and 24 bit (5 LVDS pair) color depths. Per the SMARC specification, the Module must support 18 bit single channel LVDS, should support 24 bit single channel LVDS in the 18 bit compatible LVDS format, and may support 24 bit single channel LVDS in the 24 bit standard LVDS format. (There is a more detailed discussion of the LVDS formats in the SMARC specification document). The most common Module LVDS format will be 18 bit single channel LVDS.

The connectors used for the KLAS Mezzanine to Evaluation Carrier are:

Vendor	Vendor P/N	Where Used	Kontron PN
Hirose	FX12B-60S-SV	SMARC Evaluation Carrier	1052-2683
Hirose	FX12B-60P-SV	KLAS Mezzanine PCB	1052-2681

These connectors are fine pitch (0.4mm) low profile (1.5mm board to board) parts with excellent signal integrity characteristics. The connector vendor claims operation to 6 GHz and beyond.

The SMARC Evaluation Carrier has no parts, other than the Hirose FX12 connector and mounting standoffs, in the shadow of the 43mm x 18mm KLAS board. The KLAS boards may thus have parts on the bottom side, up to 1.3mm tall. Top side KLAS part height should be limited to 3mm.

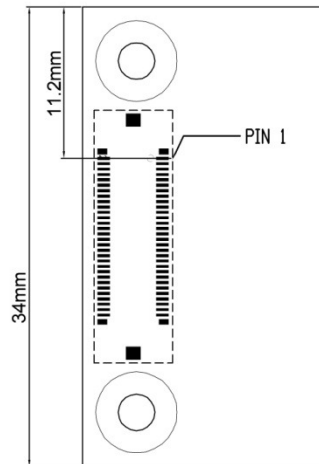

NOTE: Connector is mounted in the bottom side of the PCB and is seen 'through' the board in this view.

TOP VIEW

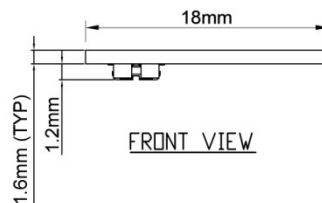

FRONT VIEW

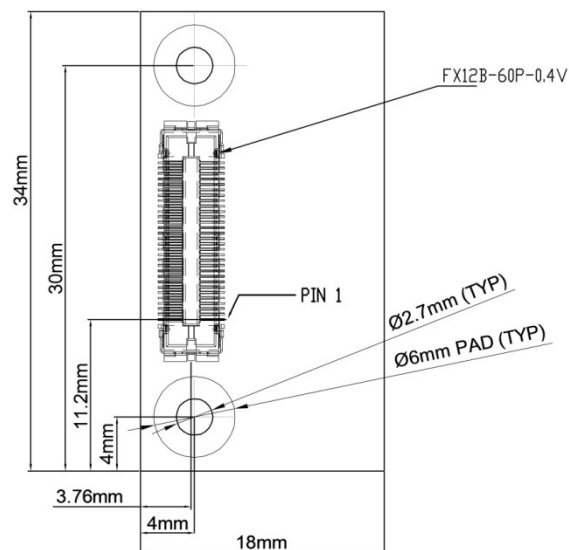

BOTTOM VIEW

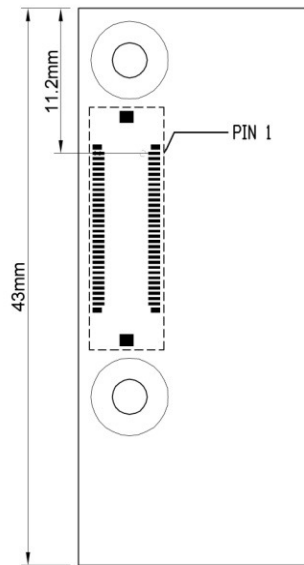

NOTE: Connector is mounted in the bottom side of the PCB and is seen "through" the board in this view.

TOP VIEW

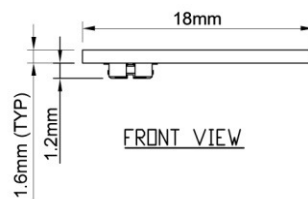

FRONT VIEW

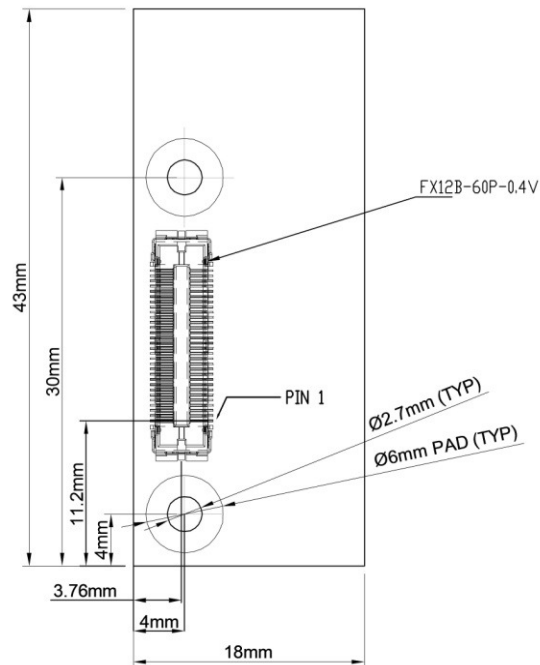

BOTTOM VIEW

Figure 10. KLAS Board 43mm x 18mm Outline

The KLAS Module connector pin-out is as follows.

Pin Number	Description	Pin Number	Description
1	GND	2	LCD_I2C_DAT
3	ODD_0+	4	LCD_I2C_CK
5	ODD_0-	6	V_3V3
7	GND	8	V_3V3
9	ODD_1+	10	PORTRAIT#
11	ODD_1-	12	V_3V3_SWITCHED
13	GND	14	V_3V3_SWITCHED
15	ODD_2+	16	SIX_BIT_PACK#
17	ODD_2-	18	V_5V
19	GND	20	V_5V
21	ODD_CK+	22	NC
23	ODD_CK-	24	V_12V
25	GND	26	V_12V
27	ODD_3+	28	V_12V
29	ODD_3-	30	NC
31	GND	32	PNL_EN
33	EVEN_0+	34	BKL_EN
35	EVEN_0-	36	BKL_PWM
37	GND	38	V_LED+
39	EVEN_1+	40	V_LED+
41	EVEN_1-	42	V_LED+
43	GND	44	V_LED+
45	EVEN_2+	46	NC

47	EVEN_2-	48	NC
49	GND	50	V_LED_STRING_1-
51	EVEN_CK+	52	V_LED_STRING_2-
53	EVEN_CK-	54	V_LED_STRING_3-
55	GND	56	V_LED_STRING_4-
57	EVEN_3+	58	V_LED_STRING_5-
59	EVEN_3-	60	V_LED_STRING_6-

Notes for KLAS pin-out table:

- » All logic signals (LCD\_I2C\_DAT, LCD\_I2C\_CK, PNL\_EN, BKL\_EN, BKL\_PWM) are 3.3V level signals.
- » Single channel LVDS displays use the ODD LVDS pairs only, and leave EVEN not connected.
- » Six bit per color (aka 18 bit color depth) do not use the 4<sup>th</sup> LVDS data pair
- » Some displays have a PORTRAIT / LANDSCAPE mode pin strap. If the display supports this, then the display should operate in Landscape mode if the KLAS PORTRAIT# pin is floating, and should operate in Portrait mode if the KLAS PORTRAIT# pin is driven low by the Carrier.
- » Some displays have a pin strap to allow either 8 bit per color or 6 bit per color compatible LVDS packing. If the display supports this, then the display should be set for 8 bit per color packing if the KLAS SIX\_BIT\_PACK# is floating, and should be set for 6 bit per color packing if the SIX\_BIT\_PACK# pin is driven low by the Carrier.
- » The number of LED strings used by displays varies with display makes and models. Some of the LED strings may be left open in many implementations.

## 11 I/O Mezzanine

The I/O Mezzanine site accepts a 68mm x 52mm I/O Module. The I/O Module may be created by Kontron or by Kontron customers.

The Evaluation Carrier interface to the I/O Module is over a 100 pin Hirose FX8 connector pair.

Vendor	Vendor P/N	Where Used	Kontron PN
Hirose	FX8-100S-SV	SMARC Evaluation Carrier	1051-7773
Hirose	FX8-100P-SV	IO Mezzanine Board	1044-9102

The separation between the SMARC Evaluation Carrier top side and the I/O Mezzanine PCB bottom side is 3mm. Standoffs with threads for M2.5 hardware are present on the Evaluation Carrier. There are no parts on the Evaluation Carrier in the shadow of the I/O Mezzanine, except for the mating Hirose connector and the standoffs. Hence parts up to 2.5mm tall may be placed on the bottom side of the I/O Mezzanine PCB. On the top side, a part height limit of 6mm is advised.

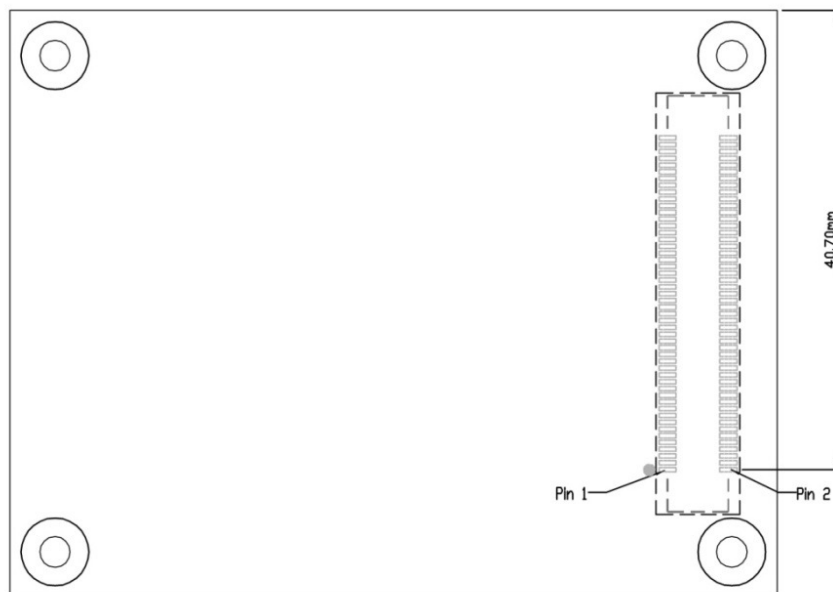

NOTE: Connector is mounted in the bottom side of the PCB and is seen 'through' the board in this view

TOP VIEW

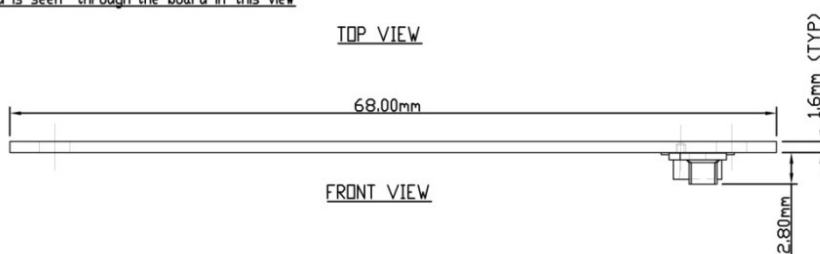

FRONT VIEW

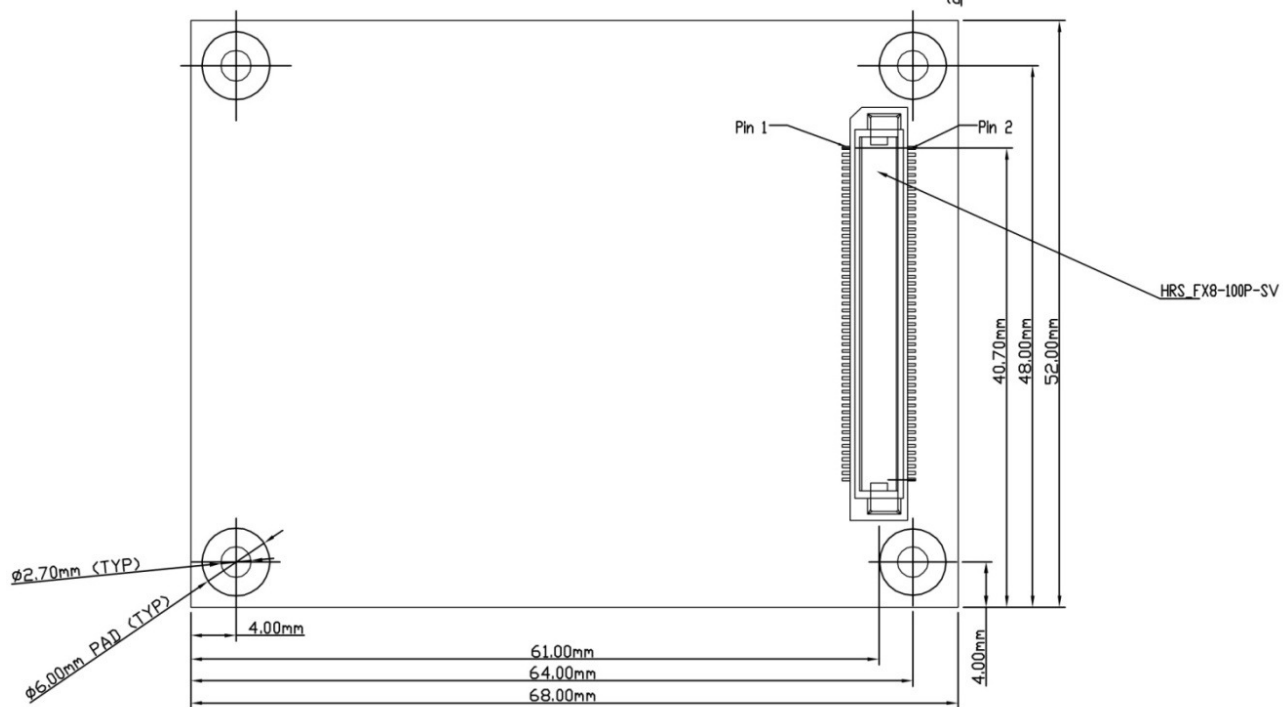

BOTTOM VIEW



Figure 11. I/O Mezzanine Card Outline

Pin Number	Description	Pin Number	Description
1	GND	2	GND
3	SPI0_CS0#	4	AUDIO_MCLK
5	SPI0_CS1#	6	GND
7	SPI0_CK	8	I2S0_LRCK
9	SPI0_DIN	10	I2S0_SDOUT
11	SPI0_DO	12	I2S0_SDIN
13	GND	14	I2S0_CK
15	SPI1_CS0#	16	GND
17	SPI1_CS1#	18	I2S1_LRCK
19	SPI1_CK	20	I2S1_SDOUT
21	SPI1_DIN	22	I2S1_SDIN
23	SPI1_DO	24	I2S1_CK
25	GND	26	GND
27	USB0+	28	I2S2_LRCK
29	USB0-	30	I2S2_SDOUT
31	GND	32	I2S2_SDIN
33	USB1+	34	I2S2_CK
35	USB1-	36	GND
37	GND	38	I2C_LCD_DAT
39	NC	40	I2C_LCD_CK
41	NC	42	I2C_GP_DAT
43	NC	44	I2C_GP_CK
45	NC	46	I2C_PM_DAT
47	GPIO0/CAM0_PWR#	48	I2C_PM_CK

49	GPIO1/CAM1_PWR#	50	I2C_CAM_DAT
51	GPIO2/CAM0_RST#	52	I2C_CAM_CK
53	GPIO3/CAM1_RST#	54	GND
55	GPIO4/HDA_RST#	56	WDT_TIME_OUT#
57	GPIO5/PWM_OUT	58	PCIE_WAKE#
59	GPIO6/TACHIN	60	SLEEP#
61	GPIO7/PCAM_FLD	62	CARRIER_STBY#
63	GPIO8/CAN0_ERR#	64	RESET_OUT#
65	GPIO9/CAN1_ERR#	66	RESET_IN#
67	GPIO10	68	GND
69	GPIO11	70	SER0_TX
71	GND	72	SER0_RX
73	SPDIF_OUT	74	SER0_RTS#
75	SPDIF_IN	76	SER0_CTS#
77	V_IO	78	SER1_TX
79	V_IO	80	SER1_RX
81	GND	82	SER0_1_MEZ_KILL#
83	1.8V	84	GND
85	1.8V	86	SER2_TX
87	GND	88	SER2_RX
89	3.3V	90	SER2_RTS#
91	3.3V	92	SER2_CTS#
93	GND	94	SER3_TX
95	5.0V	96	SER3_RX
97	5.0V	98	SER2_3_MEZ_KILL#
99	5.0V	100	NC

## Notes:

- » Signal SER0\_1\_MEZ\_KILL# should be tied low on the I/O Module if the I/O Module intends to drive any of the SER0 or SER1 lines. Tying SER0\_1\_MEZ\_KILL# low disables the Evaluation Carrier Serial Port 0 and 1 transceiver.
- » Signal SER2\_3\_MEZ\_KILL# should be tied low on the I/O Module if the I/O Module intends to drive any of the SER2 or SER3 lines. Tying SER2\_3\_MEZ\_KILL# low disables the Evaluation Carrier Serial Port 2 and 3 transceivers.
- » The I/O Module should use V\_IO for its I/O buffers. Per the SMARC specification, V\_IO may be 1.8V or 3.3V, with most systems using 1.8V I/O.

## 12 MMC Mezzanine

The eMMC Mezzanine is a 29.5mm x 32mm board that allows eMMC devices of various capacities and from various vendors to be prototyped with the SMARC Evaluation Carrier board.

Vendor	Vendor P/N	Connector type	Kontron PN
Hirose	FX12B-40P-0.4SV	SMARC carrier connector	1051-1278
Hirose	FX12B-40S-0.4SV	eMMC Mezzanine Module connector	1051-1279

The separation between the SMARC Evaluation Carrier top side and the eMMC Mezzanine PCB bottom side is 1.5mm. Standoffs with threads for M2.5 hardware are present on the Evaluation Carrier. There are no parts on the Evaluation Carrier in the shadow of the eMMC Mezzanine, except for the mating Hirose connector and the standoffs. Hence parts up to 1.3mm tall may be placed on the bottom side of the eMMC Mezzanine PCB.

The Kontron eMMC Mezzanine cards fabricated to date have all the eMMC Mezzanine card parts on the bottom of the eMMC Mezzanine card, facing the Evaluation Carrier PCB top side. There are no parts on the top side of this card. This was done to allow a 4 layer PCB and to have a lower fabrication cost by having all parts on one side of the PCB. This is evident in the following figure. The left photo shows the bottom of the eMMC Mezzanine card, that mates with the Evaluation Carrier. The right photo shows the top of the card.



Figure 12. eMMC Mezzanine Card

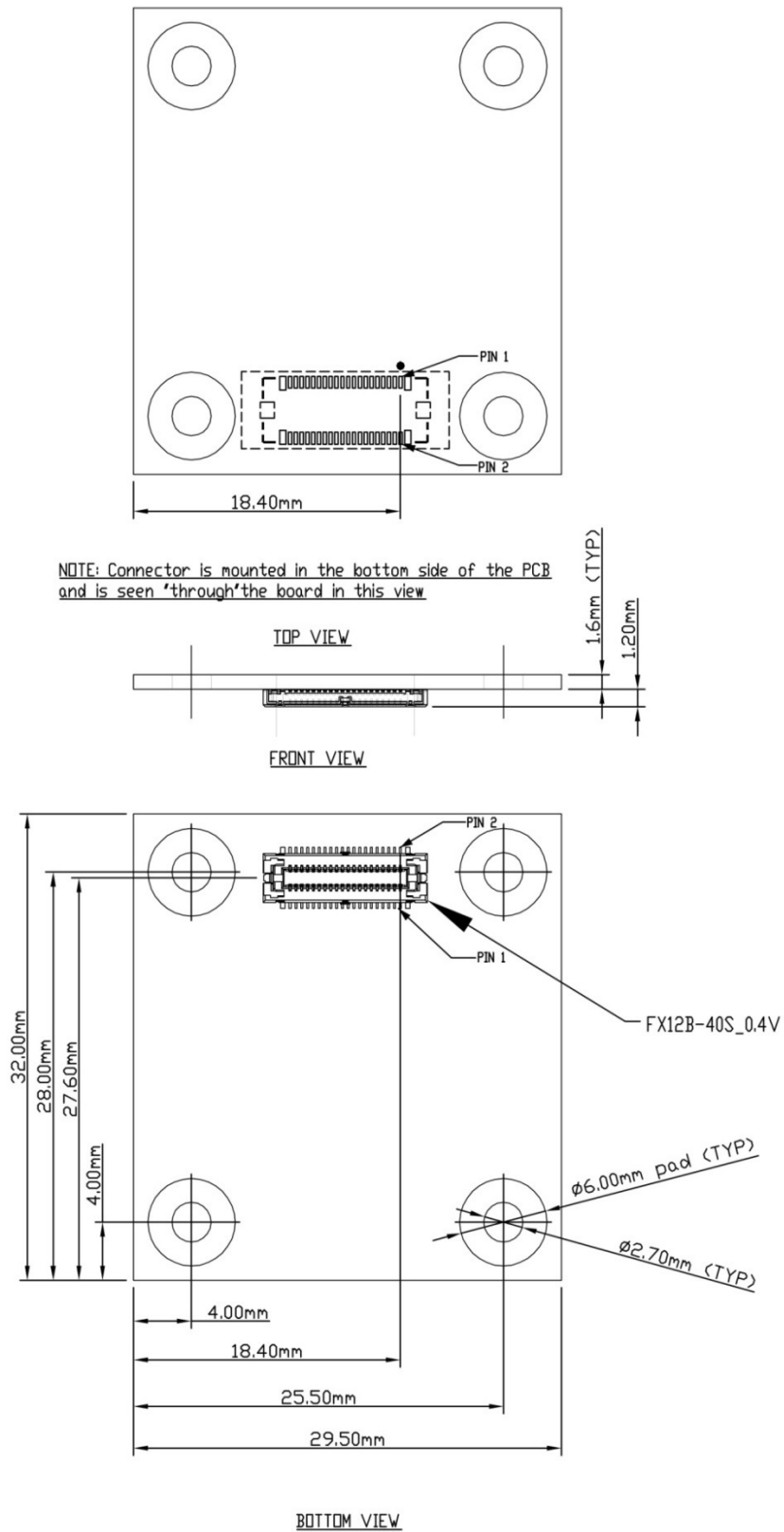

**Figure 13. eMMC Mezzanine Card Outline**

The pin-out used for the eMMC Mezzanine interface is shown in the following table. Per the SMARC specification, the IO interface may run at either 1.8V or 3.3V. Usually 1.8V is used.

Per the eMMC specification, the data interface may be used in 8 bit, 4 bit or 1 bit modes. If using a 4 bit mode, then SDMMC\_D[5] through SDMMC\_D[7] are simply left unconnected.

Pin Number	Description	Pin Number	Description
1	SDMMC_D[7]	2	V_3V3
3	GND	4	V_3V3
5	SDMMC_D[6]	6	GND
7	GND	8	GND
9	SDMMC_D[2]	10	GND
11	GND	12	GND
13	SDMMC_D[1]	14	GND
15	GND	16	GND
17	SDMMC_D[5]	18	GND
19	GND	20	GND
21	SDMMC_D[0]	22	GND
23	GND	24	GND
25	SDMMC_D[4]	26	GND
27	GND	28	GND
29	SDMMC_D[3]	30	GND
31	GND	32	GND
33	SDMMC_RST#	34	GND

Pin Number	Description	Pin Number	Description
35	SDMMC_CMD	36	GND
37	NC	38	V_IO (usually 1.8V)
39	SDMMC_CLK	40	V_IO (usually 1.8V)

## 13 Camera Mezzanine

The Camera Mezzanine is a 50mm x 26mm board that allows various cameras, serial and parallel, to be prototyped with the SMARC Evaluation Carrier board.

Vendor	Vendor P/N	Connector type	Kontron PN
Hirose	FX12B-60P-0.4SV	SMARC carrier connector	1052-2681
Hirose	FX12B-60S-0.4SV	Camera Mezzanine Module connector	1052-2683

The separation between the SMARC Evaluation Carrier top side and the Camera Mezzanine PCB bottom side is 1.5mm. Standoffs with threads for M2.5 hardware are present on the Evaluation Carrier. There are no parts on the Evaluation Carrier in the shadow of the Camera Mezzanine, except for the mating Hirose connector and the standoffs. Hence parts up to 1.3mm tall may be placed on the bottom side of the Camera Mezzanine PCB. On the top side, a part height limit of 6mm is advised.

If through hole parts are used on the Camera Mezzanine PCB, be careful that the solder tits do not touch the surface of the Evaluation Carrier. Through hole parts are not advised.

A camera may be mounted directly to the Camera Mezzanine for test, or cabled to the Camera Mezzanine. Flex circuits or rigid-flex circuits can be considered, to allow camera(s) mounting.



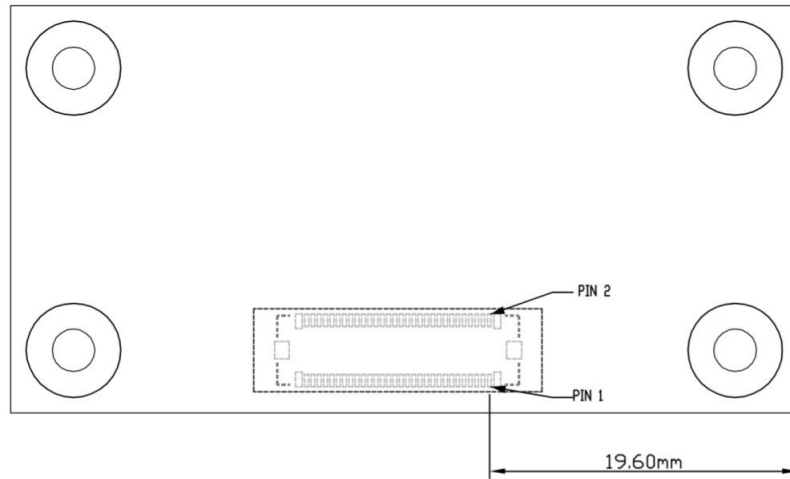

NOTE: Connector is mounted in the bottom side of the PCB and is seen "through" the board in this view

TOP VIEW

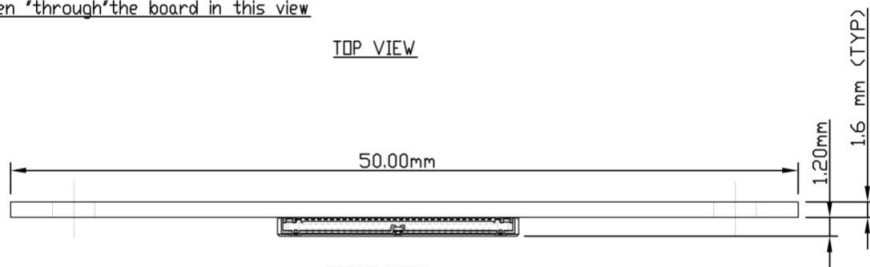

FRONT VIEW

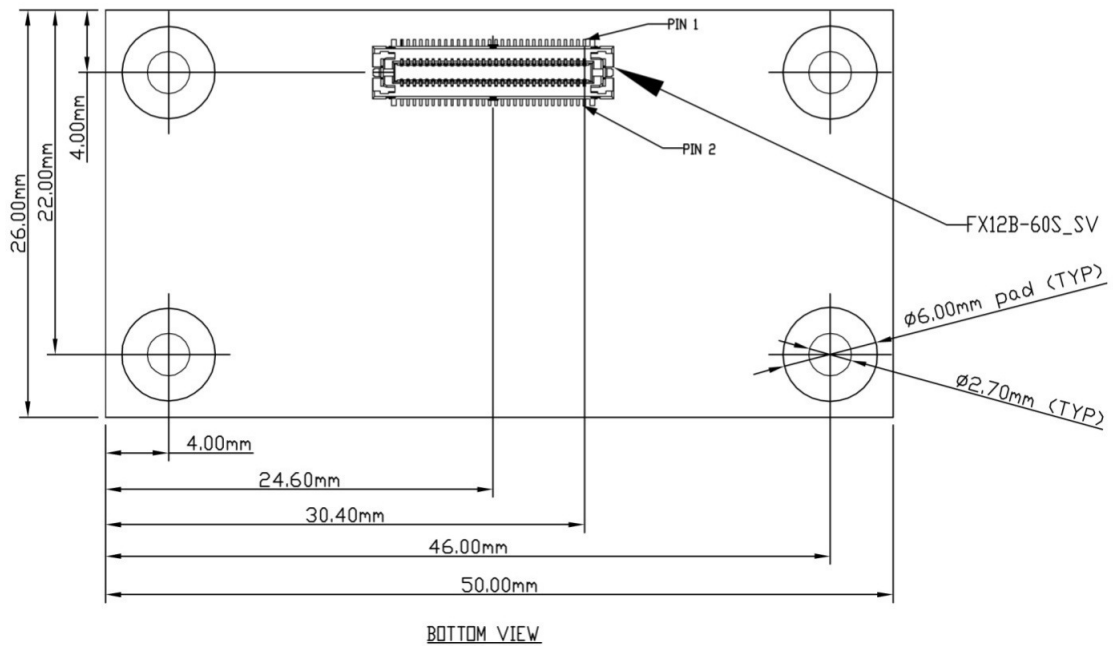

BOTTOM VIEW

Figure 14. Camera Mezzanine Card Outline

The Camera Mezzanine pin-out to the Carrier is shown in the following table:

Pin Number	Description	Pin Number	Description
1	PCAM_PXL_CK1	2	GND
3	GND	4	PCAM_PXL_CK0
5	PCAM_D0/CSI1_CK_P	6	GND
7	PCAM_D1/CSI1_CK_N	8	I2C_CAM_CK
9	GND	10	I2C_CAM_DAT
11	PCAM_D2/CSI1_D0_P	12	GND
13	PCAM_D3/CSI1_D0_N	14	CAM_MEM_CK
15	GND	16	GND
17	PCAM_D4/CSI1_D1_P	18	PCAM_ON_CSI0#
19	PCAM_D5/CSI1_D1_N	20	NC
21	GND	22	NC
23	PCAM_D6/CSI1_D2_P	24	NC
25	PCAM_D7/CSI1_D2_N	26	CAM1_PWR#
27	GND	28	CAM1_RST#
29	PCAM_D8/CSI1_D3_P	30	NC
31	PCAM_D9/CSI1_D3_N	32	GND
33	GND	34	PCAM_VSYNC
35	PCAM_DE	36	PCAM_HSYNC
37	PCAM_MCK	38	GND
39	GND	40	CSI0_CK_P/PCAM_D10
41	PCAM_ON_CSI1#	42	CSI0_CK_N/PCAM_D11
43	CAM0_PWR#	44	GND

45	CAM0_RST#	46	CSI0_D0_P/PCAM_D12
47	PCAM_FLD	48	CSI0_D0_N/PCAM_D13
49	GND	50	GND
51	3.3V	52	CSI0_D1_P/PCAM_D14
53	3.3V	54	CSI0_D1_N/PCAM_D15
55	1.8V	56	GND
57	1.8V	58	V_IO
59	NC	60	V_IO

**Caution!** The Camera Mezzanine must ensure that parallel cameras are not powered on unless the PCAM\_ON\_CSI0# signal is low (for parallel camera signals on CSI0) and PCAM\_ON\_CSI1# is low (for parallel camera signals on CSI1). Refer to the SMARC specification document for details.

## 14 AFB Mezzanine

The AFB (“Alternative Function Block”) is a set of pins in the SMARC Module specification that are set aside for various alternative functions that are project and design specific. Some of the possibilities include but are not limited to a MOST Media Local Bus interface; a 2<sup>nd</sup> GBE interface, or a Fieldbus interface.

The connector used is a Samtec part designed for high speed differential pair use. The selected part allows for up to 20 differential pairs. The parts used are shown in the flowing table.

Vendor	Vendor P/N	Connector type	Kontron PN
Samtec	QSH-020-01-L-D-DP-A	SMARC Evaluation Carrier	1052-2542
Samtec	QTH-020-01-L-D-DP-A	AFB Mezzanine	

There is also a cabled version of the Samtec connector that will mate with the part used on the Evaluation Carrier for AFB use.

The AFB Mezzanine is a 50mm x 36mm card, as shown in the figure on the following page. The board - to - board spacing is 5mm. Standoffs with M2.5 threads are present on the Evaluation Carrier.

There are no parts in the shadow of the AFB Mezzanine (except for 4 standoffs and the Samtec connector) on the Evaluation Carrier. A bottom side maximum component height of 3mm is recommended. On the AFB top side, tall parts such as a GBE Mag-Jack may be used.

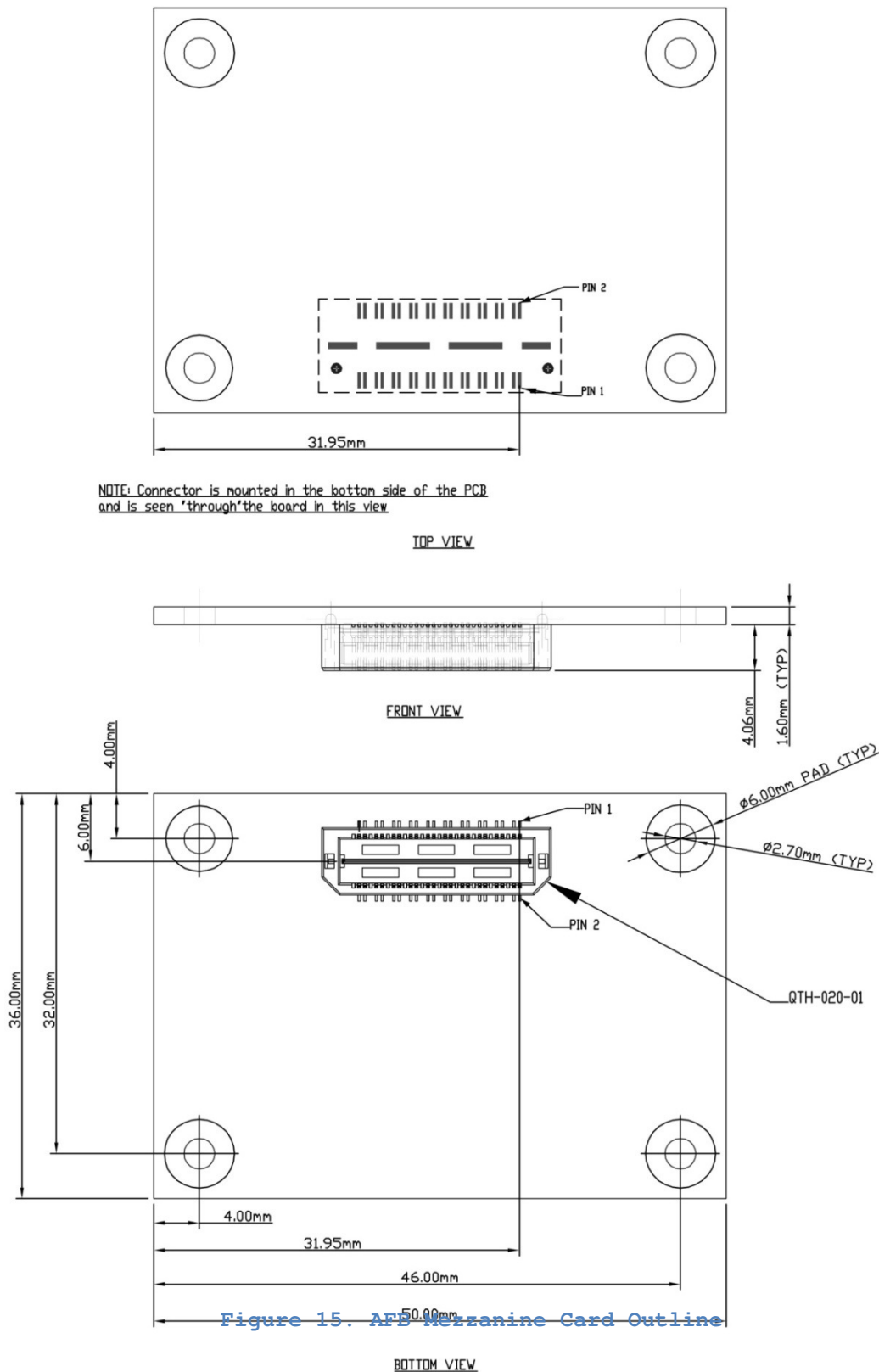

**BOTTOM VIEW**

The AFB Mezzanine card signal pin-out is given in the following table. The 40 signal pins are arranged by the connector design into pairs for high speed differential pair use. This is suggested in the table by the blank lines

between pairs. Not shown are the GND connections. The Samtec connector used has 4 large dedicated GND / shield pins.

Pin Number	Description	Pin Number	Description
1	AFB_DIFF4-	2	NC
3	AFB_DIFF4+	4	NC
5	NC	6	NC
7	NC	8	AFB7_PTIO
9	AFB_DIFF3-	10	NC
11	AFB_DIFF3+	12	AFB6_PTIO
13	AFB_DIFF1-	14	AFB5_IN
15	AFB_DIFF1+	16	AFB4_IN
17	AFB_DIFF2-	18	AFB3_IN
19	AFB_DIFF2+	20	AFB2_OUT
21	AFB_DIFF0-	22	NC
23	AFB_DIFF0+	24	AFB9_PTIO
25	AFB8_PTIO	26	AFB1_OUT
27	NC	28	AFB0_OUT
29	NC	30	V_IO
31	NC	32	V_IO
33	I2C_GP_CK	34	MLB_INT
35	I2C_GP_DAT	36	NC
37	3.3V	38	3.3V
39	3.3V	40	12V

**Caution!** Pins marked NC are not connected (to anything - and are not connected to each other).

## 15 I2C Buses and Devices

### 15.1 I2C Bus Summary

There are five I2C buses defined in the SMARC specification: PM (Power Management), LCD (Liquid Crystal Display), GP (General Purpose), CAM (Camera) and HDMI. There are I2C devices on the Evaluation Carrier for four of these: the PM, LCD, GP and CAM I2C buses, per the following table. There are no Evaluation Carrier board I2C devices on the SMARC HDMI I2C bus. More details on the individual devices are given in the following sections. Items shown in the shaded rows are not present on the Evaluation Carrier and are shown for illustration as to what else might appear on an I2C bus scan.

I2C Device Summary Chart:

#	Device	Description	Ref Des	Address(7 bit)	Address(8 bit)	Notes
I2C_PM Bus						
1	TI TCA9554	IO Expander	U35	0x22	0x44 / 0x45	Power Enables (Outputs)
2	TI TCA9554	IO Expander	U34	0x24	0x48 / 0x49	Power Status
3	Atmel AT24C32D	EEPROM	U37	0x57	0xAE / 0xAF	Should have PICMG EEP data structure
4	BQ27510-G2 or BQ34Z100	Fuel Gauge	U8/U23	0x55	0xAA / 0xAB	
5	TI TPS65911C	PMU	U7	0x2D	0x5A / 0x5B	On Kontron's SMARC sAT30 Module. Other SMARC Modules may have different devices, at different addresses, except for the EEPROM which should be the same
6	On Semi NCT72	Thermal Sensor	U5	0x4C	0x98 / 0x99	
7	Atmel AT24C32D	EEPROM	U9	0x50	0xA0 / 0xA1	
8	TI TPS62361	Buck Regulator	U8	0x60	0xC0 / 0xC1	
I2C_LCD Bus						
1	Atmel AT24C32D	EEPROM	U29	0x55	0xAA / 0xA1	For test

2	Atmel AT24HC02	EEPROM	U1	0x50	0xA0 / 0xA1	On KLAS board NEC
I2C_GP Bus						
1	AtmelAT24HC0 2	EEPROM	U26	0x56	0xAC / 0xAD	For test
2	STMicro LIS302DL	Acceleromete r	U1	0x1C	0x38 / 0x39	
3	TI TCA9554	IO Expander	U44	0x20	0x40 / 0x41	GPIO readback / test
4	TI TCA9554	IO Expander	U43	0x21	0x42 / 0x43	GPIO readback / test and miscellaneous control
5	TI TCA9554	IO Expander	U33	0x24	0x48 / 0x49	Miscellaneous control
6	Wolfson WM8903	Audio Codec	U54	0x1B	0x36 / 0x37	
7	NS LP8545	Backlight LED Supply	U16	0x54		May not be visible - this device has PWM and I2C modes - initial builds are with PWM modes.
I2C_CAM Bus						
1	Atmel AT24HC02	EEPROM	U31	0x54	0xA8 / 0xA9	
HDMI I2C Bus						
1						No HDMI I2C devices on the Eval Carrier. I2C device(s) should be visible if an HDMI display is connected.



## 15.2 I2C Bus Power Domains

The Evaluation Carrier I2C\_PM bus devices are in the Module Power Domain, and not in the Carrier Power Domain. This allows the Module to use the I2C\_PM bus for monitoring and controlling power on the Evaluation Carrier. The other I2C buses (I2C\_LCD, I2C\_GP, I2C\_CAM, and HDMI) are in the Carrier Power Domain.

## 15.3 I2C PM Bus I/O Expanders

There are two I/O expanders on the I2C\_PM bus. One is used to enable / disable various power rails on the Evaluation Carrier, and the other to monitor the Power Good status of most these rails.

The use of these I/O expanders is optional, and the Evaluation Carrier can function without any manipulation of these devices. The devices power up such that all of their I/O pins are inputs, and pull-up or pull-down resistors ensure that the default function is in the 'Enabled' state.

Part	Address (7 bit)	Address (8 bit)	I/O (Use as Output)	Default 1 R275 Out	Default 2 R275 In	
U35 TI TCA9554	0x22	0x44 / 0x45	P0	V_5V0_EN	Enabled	CARRIER_PWR_ON
			P1	V_3V3_EN	Enabled	CARRIER_PWR_ON
			P2	V_1V8_EN	Enabled	CARRIER_PWR_ON
			P3	V_1V5_EN	Enabled	CARRIER_PWR_ON
			P4	V_5V0_USB_EN	Enabled	CARRIER_PWR_ON
			P5	V_3V3_PCIE_EN	Enabled	CARRIER_PWR_ON
			P6	CAN0_1V8_EN	Enabled	CARRIER_PWR_ON
			P7	CAN1_1V8_EN	Enabled	CARRIER_PWR_ON

Part	Address (7 bit)	Address (8 bit)	I/O (Use as Input)	Notes
U34 TI	0x24	0x48 / 0x49	P0	PG_5V0 Power Good - 5V rail
			P1	PG_3V3 Power Good - 3.3V rail

TCA9554		P2		Not used
		P3	PG_1V5	Power Good - 1.5V rail
		P4	PG_5V0_USB	Power Good - 5V USB rail
		P5	PG_3V3_PCIE	Power Good - 3.3V PCIE rail
		P6	PG_SWITCHER	Power Good - Bat Step Down
		P7		Not used

If resistor R275 is omitted, then the power rails shown above come on whenever the Evaluation Carrier has power. If R275 is installed with a low value resistor, then the power rails are disabled until the Module asserts the CARRIER\_PWR\_ON signal

## 15.4 I2C GP Bus I/O Expanders

There are three I/O expanders on the I2C\_GP bus, described in the tables below. "Module" notation means that the pull-up is on the Module (weak pull-up per the SMARC specification)

Device	I2C Address	Output		Function	Pulled
					Hi / Low
U44 TI TCA9554	0x20 (7 bit)	P0	GPIO0/CAM0_PWR#	GPIO0 R/W	Module
		P1	GPIO1/CAM1_PWR#	GPIO1 R/W	Module
		P2	GPIO2/CAM0_RST#	GPIO2 R/W	Module
	0x40 / 0x41 (8 bit)	P3	GPIO3/CAM1_RST#	GPIO3 R/W	Module
		P4	GPIO4/HDA_RST#	GPIO4 R/W	Module
		P5	GPIO5/PWM_OUT	GPIO5 R/W	Module
		P6	GPIO6/TACHIN	GPIO6 R/W	Module

		P7	GPIO7/PCAM_FLD	GPIO7 R/W	Module
--	--	----	----------------	-----------	--------

Device	I2C Address	Output		Function	Pulled
					Hi / Low
U43 TI TCA9554	0x21 (7 bit)	P0	GPIO8/CAN0_ERR#	GPIO8 R/W	Module
		P1	GPIO9/CAN1_ERR#	GPIO9 R/W	Module
		P2	GPIO10	GPIO10 R/W	Module
		P3	GPIO11	GPIO11 R/W	Module
	0x42 / 0x43 (8 bit)	P4	LVDS_EVEN_SHDN#	Shutdown Carrier LVDS - even	Low
		P5	LVDS_ODD_SHDN#	Shutdown Carrier LVDS - odd	Low
		P6		Not used	
		P7		Not used	

Device	I2C Address	Output		Function	Pulled
					Hi / Low
U33 TI TCA9554	0x24 (7 bit)	P0	I2S0_SEL	High: I2S0 to 2 <sup>nd</sup> bus (I2S0A) Low: I2S0 to Audio CODEC	Low
		P1	I2S1_SEL	High: I2S1 loopback Low: I2S1 to I/O Mezzanine	Low
		P2	I2S2_SEL	High: I2S1 loopback Low: I2S1 to I/O Mezzanine	Low

P3	I2S0A_SEL	High: I2S0A loopback Low: I2S0A to I/O Mezzanine	Low
P4	BKLT_REF_SEL	High: I2C LED BKLT control Low: PWM LED BKLT control	Low
P5	PORTRAIT_MODE	High: PORTRAIT_MODE on Low: PORTRAIT_MODE off	Low
P6	SER0_1_XCVR_EN	High: SER0_1 XCVR Enabled Low : SER0_1_XCVR Disabled	High
P7	SER2_3_XCVR_EN	High: SER2_3 XCVR Enabled Low : SER2_3_XCVR Disabled	High

## 16 I2S Buses and Devices

### 16.1 I2S0

The SMARC I2S0 channel on the Evaluation Carrier is run through a couple of software controlled switches, allowing the following soft selections:

- » I2S0 to / from Evaluation Carrier Audio CODEC.
- » I2S0 to / from Evaluation Carrier I/O Mezzanine board.
- » I2S0 looped back on the Evaluation Carrier, for system test.

The hardware is set up to default to the first option without any software setup for the switches. To use the other options software must manipulate the switch controls. This is done via the I2C I/O expanders described in the I2C section above. The I2S0 switch routing is illustrated in the following figure.

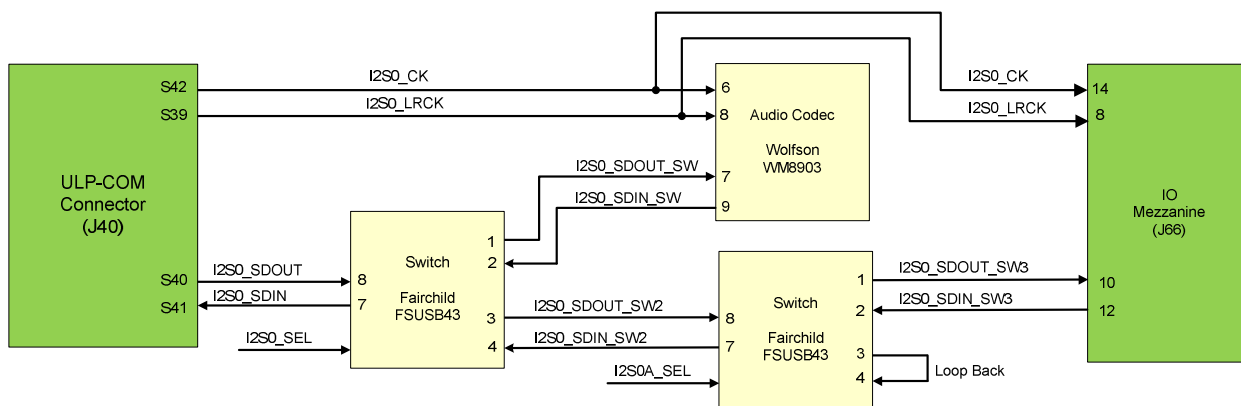

Figure 16. I2S0 Switches

On the Evaluation Carrier, the I2S0 audio CODEC used is the Wolfson WM8903, coupled with a pair of WM9001 Class D amplifiers.

### 16.2 I2S1

The SMARC I2S1 port on the Evaluation Carrier is routed through a software controlled switch. There are two switch possibilities:

- » I2S1 port goes to / from the Evaluation Carrier I/O Mezzanine.
- » Loop back for system test.

There are no active I2S1 devices on the Evaluation Carrier (the switch is a high speed analog switch, technically not an I2S device). The switch is

controlled via an I2C expander described in the I2C section above. The hardware defaults to option 1) above on power up; no special I2C set up is needed for that option.

### 16.3 I2S2

The SMARC I2S2 port on the Evaluation Carrier is routed through a software controlled switch. There are two switch possibilities:

- » I2S2 port goes to / from the Evaluation Carrier I/O Mezzanine.
- » Loop back for system test.

There are no active I2S2 devices on the Evaluation Carrier (the switch is a high speed analog switch, technically not an I2S device). The switch is controlled via an I2C expander described in the I2C section above. The hardware defaults to option 1) above on power up; no special I2C set up is needed for that option.

## 17 Power Architecture

### 17.1 Block Diagram Discussion

A block diagram of the supply architecture used on the Evaluation Carrier is shown on the following page. Some points about this diagram:

- » As outlined in the SMARC specification document, there are separate Module and Carrier power domains.
- » Some of the circuitry on the Evaluation Carrier is within the Module power domain (even those circuits are physically on the Carrier). Such circuits include the power control circuit shown at the lower left of the block diagram, and the I2C\_PM based Carrier EEPROM (not shown in this diagram).
- » All Carrier I2C\_PM devices are in the Module power domain (and are not shown in this diagram)
- » The Evaluation Carrier implements a pair of power P-FETS that allow 1.8V or 3.3V Module I/O. If the Module ties Module pin S158 (pin name VDD\_IO\_EL#) to GND, then the Module is selecting 1.8V I/O
- » If the Evaluation Carrier is built with resistor R275 not loaded, the Evaluation Carrier power rails all come up when there is input power available.
- » If R275 is loaded with a low value resistor, then the Evaluation Carrier power rails that are in the Carrier power domain do not come up until the Module asserts Module pin S154 high (Module pin name CARRIER\_PWR\_ON).
- » A pair of I/O expanders is available on the I2C\_PM bus that allows fine-grained control of the various Carrier domain power supplies. By default, these I/O expanders are inactive, all of their I/O pins are inputs, and they exert no control. They are described **Section 15.3 I2C PM Bus I/O Expanders**.

## 17.2 Figure 17 Power Architecture

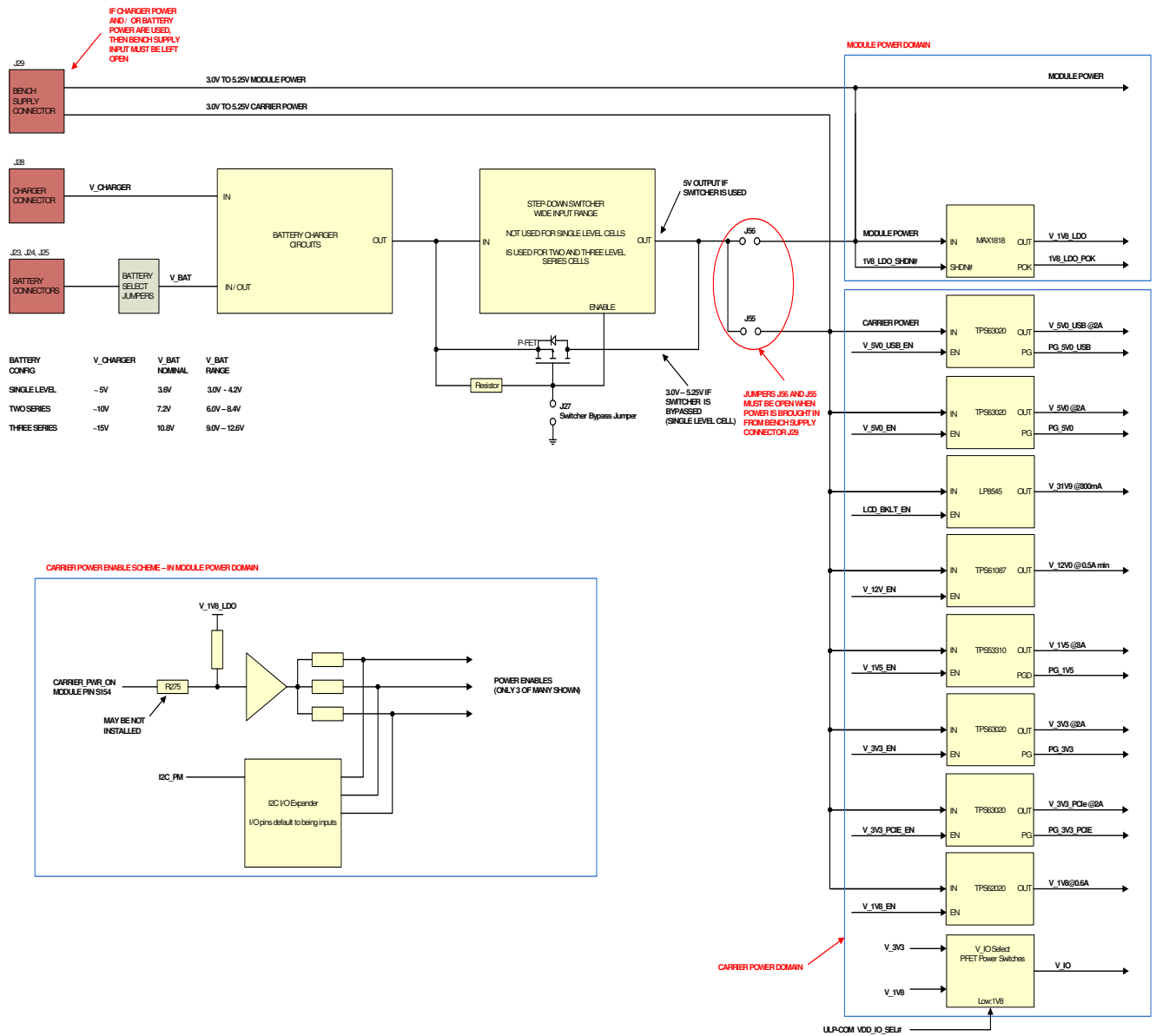

Figure 17. Power Architecture



## 18 Mechanical and Environmental Parameters

### 18.1 Mechanical Outline

Holes that may be used to mount the SMARC Evaluation Carrier to a chassis are dimensioned in the figure below. The holes are 2.7mm diameter clearance holes for use with metric M2.5 hardware.

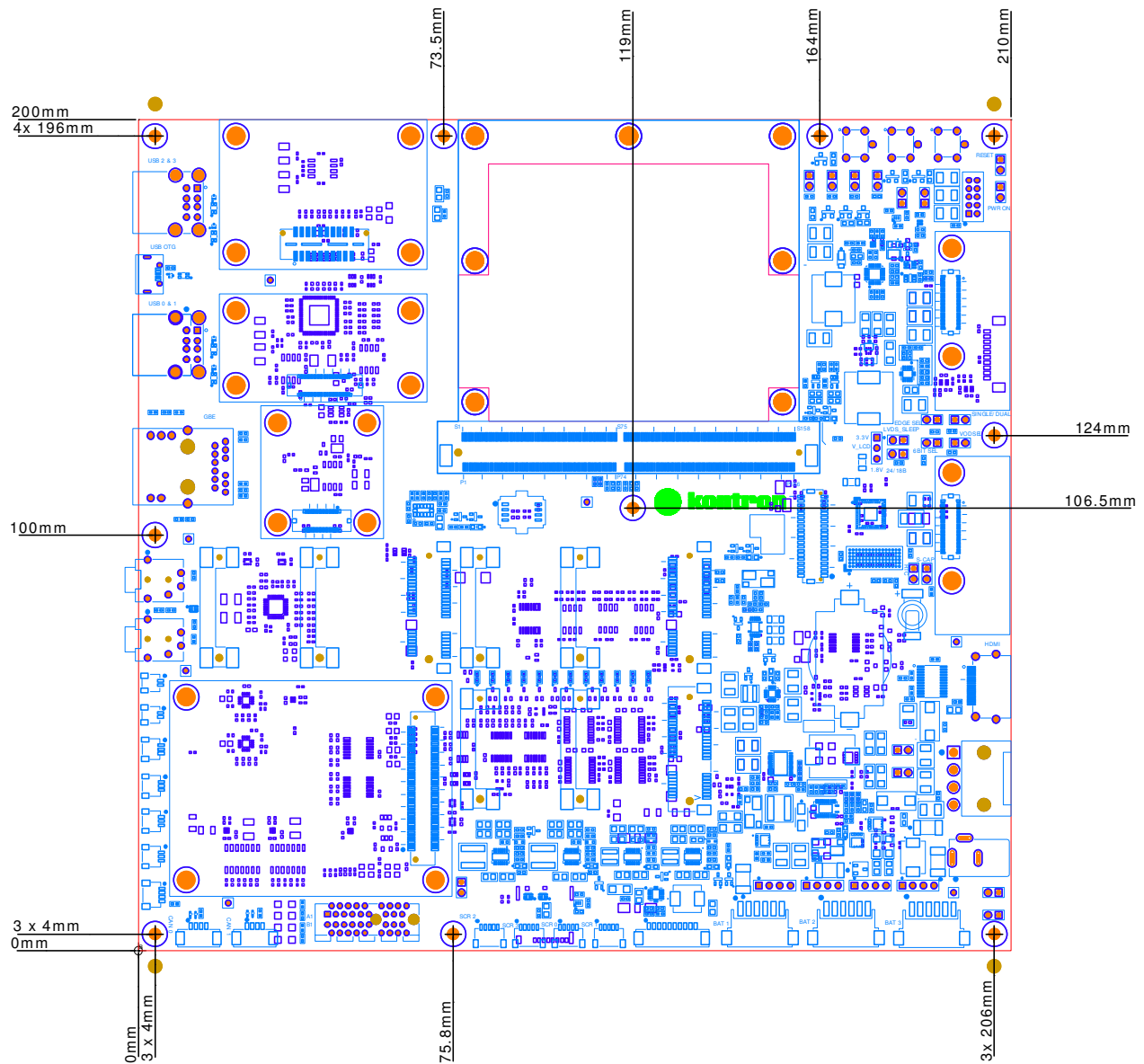

Figure 18. Mechanical Outline

## 18.2 Standoffs and Screw Hardware

All of the SMARC Evaluation Carrier mezzanine sites have captive, threaded standoffs of the correct height installed. All of these sites use PEM SMTSO surface mount standoffs with M2.5 threads. The standoffs have very good pull-strength and may be used to secure the mezzanine boards.

## 18.3 Shock and Vibration

The SMARC Evaluation Carrier is not designed to any particular shock and vibration standard.

It does have 10 mounting holes that are distributed fairly evenly across the 210mm x 200mm board area, and the Evaluation Carrier PCB is stiff as the PCB is 2mm thick, so it should be possible to create a robust system from it. However, its primary purposes are as an evaluation and development tool, and it is not intended for use in high shock and vibration environments.

## 18.4 Thermal Environment

All components, save a very limited number of exceptions, on the SMARC Evaluation Carrier are selected as Industrial Temperature range (-40 °C to +85 °C) parts.

The SMARC Carrier is validated over the -40 °C to +70 °C range.

The overall system performance depends of course on the combination of sub-systems. Some SMARC Modules are available in the Industrial Temperature range. Others are Commercial Temp range parts. Similar considerations apply to any of the Mezzanine peripherals that are used with the Evaluation Carrier.

## 18.5 Humidity

Operating: 10% to 90% RH (non-condensing).

Non-operating: 5% to 95% RH (non-condensing).

## 18.6 RoHS Compliance

The SMARC Evaluation Carrier is compliant to the 2002/95/EC RoHS directive.

## 19 Appendix A: Connector Mating Part Number Information

Connector Reference	Kontron PN	Mfg	MPN	Qty	Description	Mating Connector PN	Ref Des
Li-Ion Battery	1052-4601	TE Conn	2-292173-6	3	Header, 4-pin, SMT	173977-6	J23, J24, J25
Battery Charger Input	1046-5609	MOLEX	39-30-3035	1	Mini-Fit Jr., 3-pin, RA, Header	39-01-4030 Crimp Terminal 45750	J28
Test Bench Power Input	1051-5020	MOLEX	39303045	1	Mini-Fit Jr., 4-pin, RA, Header	39-01-4040 Crimp Terminal 45750	J29
KLAS Connector	1052-2683	Hiros e	FX12B-60S-0.4SV	2	Receptacle, 60-pin, SMT	FX12B-60P-0.4SV	J31, J32
HDMI	1050-0849	FCI	10029449-001TLF	1	HDMI Receptacle, RA, SMT	NA	J30
RS232 Header	1046-3583	JST	SM05B-SRSS-TB(LF) (SN)	4	Header, Shrouded, 5-pin, SMT	SHR-05V-S-B Crimp terminal SSH-003T-P0.2-H	J18, J19, J20, J21
Headphone TRS Jack	1051-5812	CUI	SJ-43514	1	Audio Jack, 4-pin, PTH	NA	J7
MIC TRS Jack	1051-5812	CUI	SJ-43514	1	Audio Jack, 4-pin, PTH	NA	J6
USB Type A (single)	1051-5324	TE Conn	292303-4	1	Conn USB RCP 4 POS Solder RA	NA	J3
USB Type A (dual-stacked)	1045-1459	FCI	72309-7024BLF	1	USB-A, Dual-stacked, RA, PTH	NA	J1, J4
USB micro AB OTG	1046-5754	Molex	475900001	1	USB-AB, RA, SMT	NA	J2
GBE RJ45	1045-	Bel	L829-1J1T-	1	RJ45, 1-port,	NA	J5

Connector Reference	Kontron PN	Mfg	MPN	Qty	Description	Mating Connector PN	Ref Des
	4258	Fuse	43		SMT		
Camera Mezzanine	1052-2681	Hirose	FX12B-60P-0.4SV	1	Plug, 60-pin, SMT	FX12B-60S-0.4SV	J43
AFB Mezzanine	1052-2542	Samtec	QSH-020-01-L-D-DP-A	1	High Speed Socket. 20 Diff Pairs	QTH-020-01-L-D-DP-A	J41
Boot Select Jumper	1051-5515	FCI	77311-118-02LF	13	Header, 2-pin, PTH	NA	J26, J27, J34, J35, J36, J37, J38, J39, J49, J55, J56, J58, J59
PWR/RST/RCVRY Buttons	1051-5022	Panasonic	EVQPBC04M	3	Buttons	NA	SW1, SW2, SW3
Parallel LCD Conn	1051-5578	JST	BM40B-SRDS-S-G-TF	1	Header, 40-pin, SMT	SHDR-40V-S-B Crimp terminal SSH-003GA-P0.2	J61
Micro SD Socket	1044-1719	Molex	503398-0891	1	micro-SD connector, SMT	NA	J74
eMMC Mezzanine	1051-1278	Hirose	FX12B-40P-0.4SV	1	Plug, 40-pin, SMT	FX12B-40S-0.4SV	J64
Multi-Purpose I/O Mezzanine	1051-7773	Hirose	FX8-100S-SV	1	RCP 100 POS 0.6mm	FX8-100P-SV	J66
SPI EEPROM Socket	1045-8636	Lotes	ACA-SPI-004-T02	1	SPI SOIC-8 Socket, SMT	NA	J63
Cell Selection Jumper Block	1042-7759	Samtec	TSW-104-07-F-S	4	Header, 4-pin, PTH	ESW-104-12-G-S	J50, J51, J52, J53

Connector Reference	Kontron PN	Mfg	MPN	Qty	Description	Mating Connector PN	Ref Des
Mini PCIe Socket	1044-3171	Molex	67910-0002	3	mini-PCIe connector, SMT	NA	J44, J71, J72
PCIe x1 Connector	1050-9379	Molex	87715-9002	1	PCIe x1 connector, PTH	NA	J17
KARMA Connector	1046-5833	Lotes	AAA-MXM-008-P03	1	MXM3.0, 314-pin, SMT	NA	J40
LCD Backlight Connector	1039-1228	Hirose	DF11-10DP-2DSA	1	Header, 10 pin 2mm 5x2, Vertical PTH	DF11-10DS-2R26(05) Crimp terminal DF11-EP2428PCFA	J33
2032 Battery Socket	1044-0845	Renata	SMTU2032-LF	1	2032 Battery socket	NA	BT1
microSIM Socket	1052-4772	Molex	470230001	1	microSIM Card Socket (15mm x 12mm) 6 pin	NA	J73
Speaker Connector	1037-0484	JST	SM02B-SRSS-TB	2	Header, 2-pin, SMT	SHR-02V-S-B Crimp terminal SSH-003T-P0.2-H	J8, J9
Line-In & Line-out, MIC data	1046-3590	JST	SM03B-SRSS-TB(LF) (SN)	4	Header, 3-pin, SMD	SHR-03V-S-B Crimp terminal SSH-003T-P0.2-H	J10, J11, J12, J13
CAN Bus connectors	1051-9866	Molex	53261-0471	2	Conn Shrouded Header HDR 4 POS 1.25mm	51021-0400 : Housing Crimp terminal 50058-8000	J15, J16
Mini_PCIE_latch	1044-5361	Molex	48099-4000	3	Mini PCI Latch Polyamide 6/6	NA	J46, J68, J70, (J65, J67, J69) DNI

Connector Reference	Kontron PN	Mfg	MPN	Qty	Description	Mating Connector PN	Ref Des
Battery Mgmt Connector	1046-1052	Molex	53261-1071	1	Header HDR 10 POS 1.25mm Solder RA	51021-1000 Crimp terminal 50058-8000	J22
SPDIF Header	1050-1106	JST	SM04B-SRSS-TB(LF) (SN)	1	Header, 4-pin, SMD	SHR-04V-S-B Crimp terminal SSH-003T-P0.2-H	J14
Debug	1052-7007	Samtec	TSW-101-07-F-S	7	HDR 1 POS ST Thru-Hole	NA	J42, J45, J47, J48, J54, J57, J62

## 20 Appendix B: Assembly Part Numbers

Item Description	PCB Number	Assembly Number	Orderable Part Number
SMARC Evaluation Carrier	501-146-A0	701-188	51000-0000-00-0
SMARC Development Kit			51000-0000-00-S
SMARC eMMC Mezzanine	501-151-A0	701-199	
SMARC KLAS NEC (NL12876AC18-03)	501-163-A0	701-216	
Cable for NEC (NL12876AC18-03) 10"		420-0039-00	
NEC NL12876AC18-03 Display			
KLAS JILI30	1053-5289	59200-0000-04-0	59200-0000-04-0
SMARC I/O Mezzanine	501-182-A0	701-248	
SMARC Camera Mezzanine	NA		
SMARC AFB Mezzanine	NA		
Serial Port (w DB9 connectors)		423-0549-00	
microUSB to USB type A		423-0556-00	
Battery connector pigtails		423-0546-00	
Charger connector pigtails		423-0547-00	
Test Bench connector pigtails		423-0548-00	
LCD Backlight power pigtails		423-0551-00	
Audio Line in pigtails		423-0553-00	
Audio Line out pigtails		423-0553-00	
Speaker pigtails		423-0552-00	
SPDIF pigtails		423-0555-00	
CAN pigtails		423-0554-00	



Parallel LCD pigtails		423-0550-00	
Battery Management Cable		423-0557-00	

## 21 Appendix C: Document Revision History

Revision	Date	Edited by	Changes
1.0	2012-09-14	DCruz	Initial Public Release
1.1	2014-02-03	MHumphreys	Updated for production released PCA
1.2	2017-09-12	MHumphreys	Added info for Jumpers J83, J81, J79, J78, J82
1.3	2017-09-13	MHumphreys	Corrections to J78 & deleted references to J60
1.4	2017-09-19	MHumphreys	Deleted obsolete KLAS adapters, and added the KLAS JILI30 adapter to Appendix B

### Corporate Offices

#### **Europe, Middle East & Africa**

Oskar-von-Miller-Str.  
1  
85386 Eching/Munich

#### **North America**

14118 Stowe Drive  
Poway, CA 92064-  
7147  
USA

#### **Asia Pacific**

17 Building Block  
#1,ABP.  
188 Southern West  
4th Ring

Germany  
Tel.: +49 (0)8165/ 77  
777  
Fax: +49 (0)8165/ 77  
219  
info@kontron.com

Tel.: +1 888 294  
4558  
Fax: +1 858 677  
0898  
info@us.kontron.com

Beijing 100070,  
P.R.China  
Tel.: + 86 10  
63751188  
Fax: + 86 10  
83682438  
info@kontron.cn