

» Kontron User's Guide «

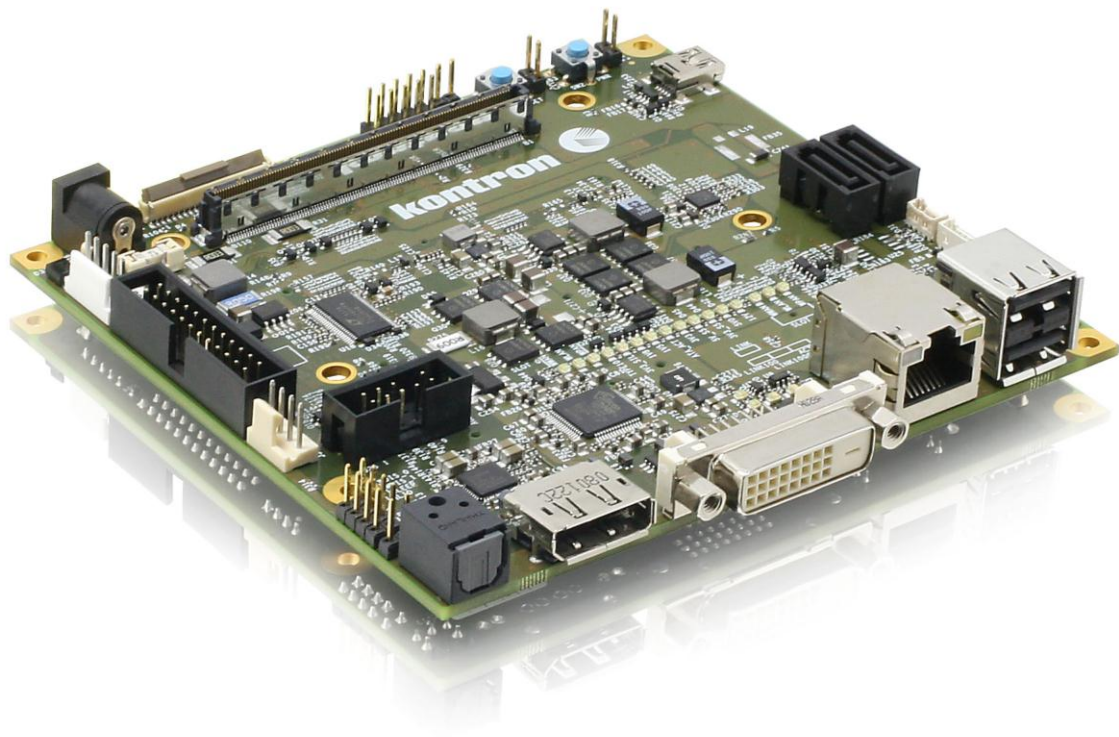

COMe Reference Carrier-i Type 10

Document Revision 1.0

» Table of Contents «

1	User Information	1
1.1	About This Document	1
1.2	Copyright Notice	1
1.3	Trademarks	1
1.4	Standards	1
1.5	Warranty	2
1.6	Technical Support	2
2	Introduction	3
3	Specification	4
3.1	Functional Specification	4
3.2	Block Diagram	5
3.3	Mechanical Specification	6
3.4	Electrical Specification	7
3.5	Environmental Specification	8
3.6	MTBF	8
4	Connector Layout	9
4.1	Rear Panel	9
4.2	Connector Locations	10
4.3	Component overview	12
5	Connectors and Features	14
5.1	Power Supply	14
5.1.1	VCC	14
5.1.2	Power and Reset Button	15
5.1.3	LID# and SLEEP# Jumper	16
5.2	COM Express® Connector	17
5.3	Status LEDs	18

5.4	Serial ATA.....	19
5.5	μSD-CARD / Module GPIO	20
5.6	High Definition Audio	22
5.7	Ethernet.....	23
5.8	USB.....	24
5.9	Mini PCI express.....	25
5.10	SIM Card.....	26
5.11	Kontron Feature Connector	27
5.12	DVI-D and Displayport	28
5.13	Serial Interface.....	29
5.14	CAN.....	30
5.15	FAN.....	31
5.16	SMART Battery.....	32
5.16.1	Introduction	32
5.16.2	Possible Smart Batteries	32
5.16.3	Smart Battery System Manager.....	32
5.16.4	Smart Battery Connector	33
6	Battery Information	34
7	Module Single Supply and Wide Range.....	36
8	Compatibility Matrix.....	37
9	Security Advice	38
10	Document Revision History.....	39

1 User Information

1.1 About This Document

This document provides information about products from Kontron Embedded Modules GmbH and/or its subsidiaries. No warranty of suitability, purpose, or fitness is implied. While every attempt has been made to ensure that the information in this document is accurate, the information contained within is supplied “as-is” and is subject to change without notice.

For the circuits, descriptions and tables indicated, Kontron assumes no responsibility as far as patents or other rights of third parties are concerned.

1.2 Copyright Notice

Copyright © 2003-2010 Kontron Embedded Modules GmbH

All rights reserved. No part of this document may be reproduced, transmitted, transcribed, stored in a retrieval system, or translated into any language or computer language, in any form or by any means (electronic, mechanical, photocopying, recording, or otherwise), without the express written permission of Kontron Embedded Modules GmbH.

DIMM-PC®, PISA®, ETX®, ETXexpress®, microETXexpress™, X-board®, DIMM-IO® and DIMM-BUS® are trademarks or registered trademarks of Kontron Embedded Modules GmbH. Kontron is trademark or registered trademark of Kontron AG.

1.3 Trademarks

The following lists the trademarks of components used in this board.

- » IBM, XT, AT, PS/2 and Personal System/2 are trademarks of International Business Machines Corp.
- » Microsoft is a registered trademark of Microsoft Corp.
- » Intel is a registered trademark of Intel Corp.
- » All other products and trademarks mentioned in this manual are trademarks of their respective owners.

1.4 Standards

Kontron Embedded Modules GmbH is certified to ISO 9000 standards.

1.5 Warranty

This Kontron Embedded Modules GmbH product is warranted against defects in material and workmanship for the warranty period from the date of shipment. During the warranty period, Kontron Embedded Modules GmbH will at its discretion decide to repair or replace defective products.

Within the warranty period, the repair of products is free of charge as long as warranty conditions are observed.

The warranty does not apply to defects resulting from improper or inadequate maintenance or handling by the buyer, unauthorized modification or misuse, operation outside of the product's environmental specifications or improper installation or maintenance.

Kontron Embedded Modules GmbH will not be responsible for any defects or damages to other products not supplied by Kontron Embedded Modules GmbH that are caused by a faulty Kontron Embedded Modules GmbH product.

1.6 Technical Support

Technicians and engineers from Kontron Embedded Modules GmbH and/or its subsidiaries are available for technical support. We are committed to making our product easy to use and will help you use our products in your systems.

Please consult our Web site at <http://www.kontron.com/support> for the latest product documentation, utilities, drivers and support contacts. Consult our customer section <http://emdcustomersection.kontron.com> for the latest BIOS downloads, Product Change Notifications and additional tools and software. In any case you can always contact your board supplier for technical support.

2 Introduction

The TBD carrier board for Type 10 modules is designed to allow embedded application developers to get up and running quickly on the COM Express® mini platform, giving them a head start on the total system design. Simply select a Type 10 TBD CPU module, then Plug & Go. The TBD is an evaluation backplane for COM Express® Computer-on-Modules following the PICMG COM.0 specification Rev 1.0 or Rev 2.0 with pin-out Type 10.

Ordering Information

Article	Part-No.	Description
TBD		
TBD		

3 Specification

3.1 Functional Specification

- » COM Express® COM.0 Rev 2.0 baseboard compatible to Type 10 pin-out based modules
- » Designed for extended temperature
- » Single supply industrial or commercial power connector (5.5 – 20V)
- » 2 x miniPCIexpress
- » SIM Card Slot connected to miniPCIexpress
- » 2x SATA
- » LVDS (40pin JILI FFC40 connector)
- » 1 x DDI (either DVI-D (SIL1364 SDV0toDVI) or Display Port, depends on module capability)
- » 1x Ethernet RJ45
- » 4 x USB 2.0/1.1 (2x front panel, 2x pin header)
- » 1 x USB Client
- » Kontron feature connector
- » Front panel connectors (HDD Act., Reset and Power Switch)
- » Status LED
- » µSD-Card Socket
- » GPIO pin header for module GPIO (multiplexed with SD-Card)
- » LID and SLEEP support
- » Power Control functions (Power Button override, module single supply, power consumption measurements)
- » Analo Devices AD1882AJCIZHDAudio Codec
 - Front panel audio
 - Optical S/PDIF output
 - Digital S/PDIF output
- » Serial COM port on SER0
- » CAN on SER1
- » Smart Battery Connector for batteries between 7.2V to 14.4V

3.2 Block Diagram

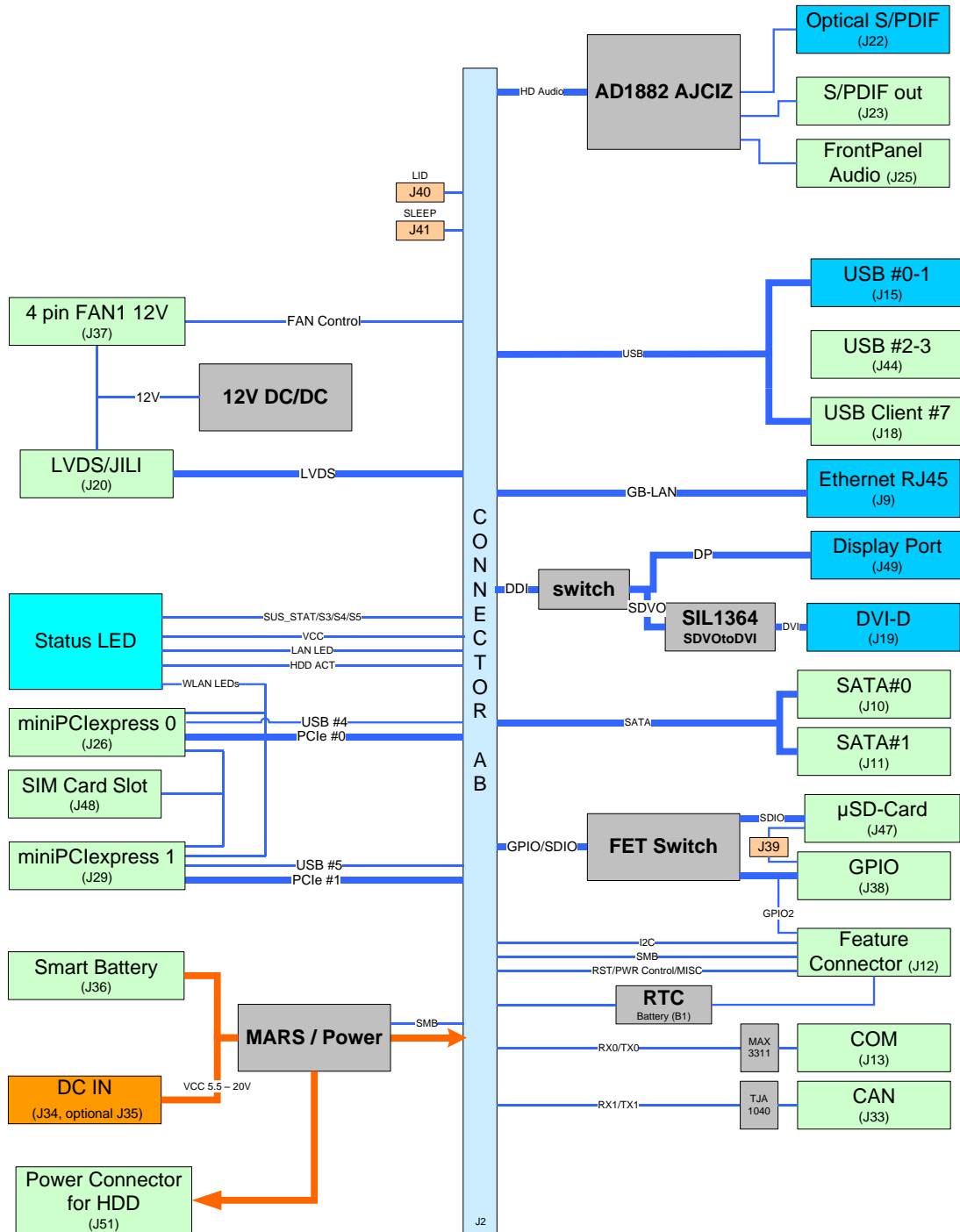

3.3 Mechanical Specification

- » Size: 120mm x 120mm
- » max height on top: 15.4mm (Connector J15)

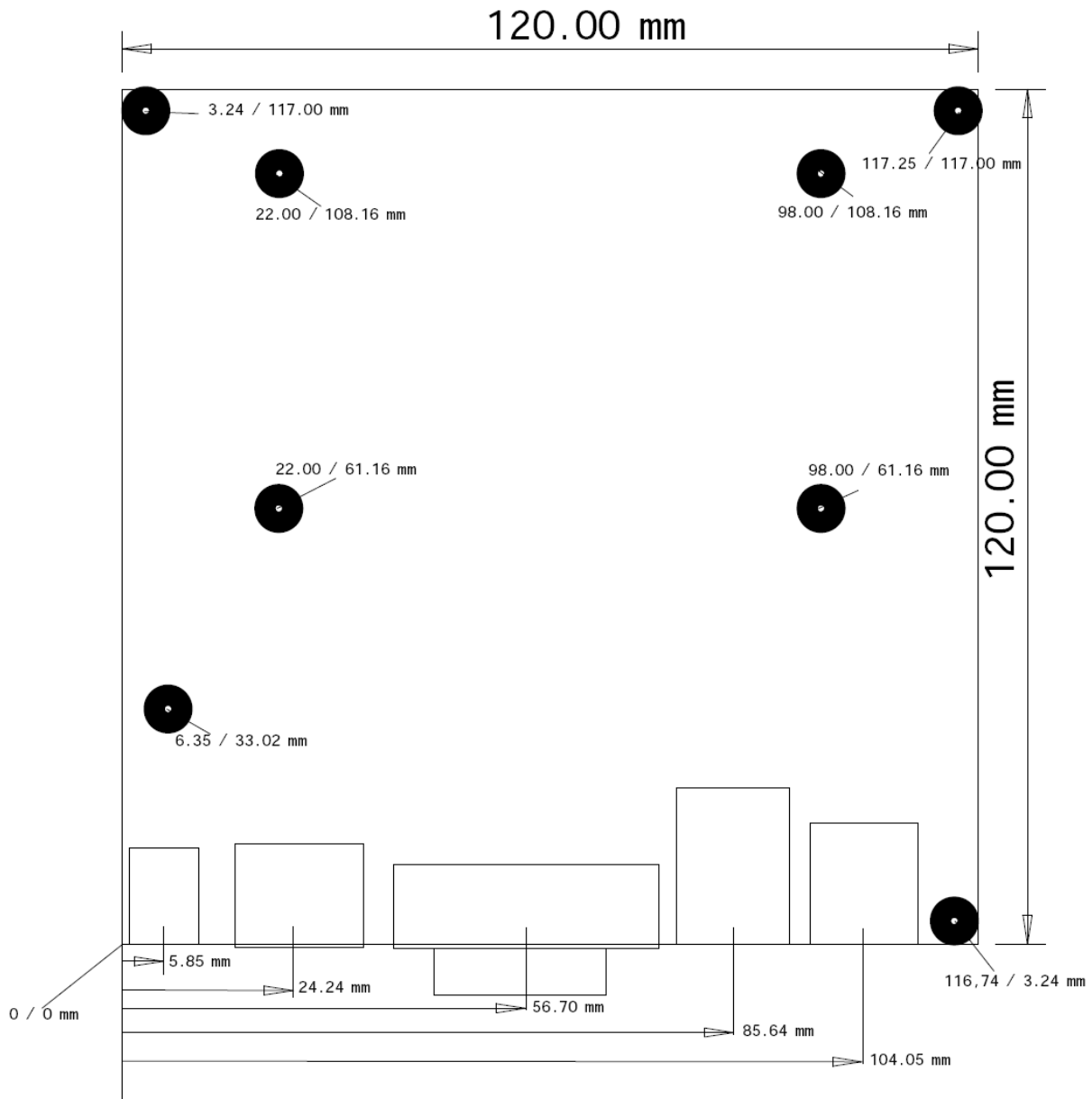

3.4 Electrical Specification

Supply Voltage

- » Single Power Supply (5.5V – 20V DC)

When external devices are supplied by the COMe Reference Carrier-I Type 10 (via HDD power and LVDS connector) and the temperature is below 0°C the carrier board supply voltage shall be > 6.5V.

Power Supply Rise time

- » The input voltages shall rise from $\leq 10\%$ of nominal to within the regulation ranges within 0.1ms to 20ms.
- » There must be a smooth and continuous ramp of each DC input voltage from 10% to 90% of its final set-point following the ATX specification

Supply Voltage Ripple

- » Maximum 100 mV peak to peak 0-20MHz

Power Connector

- » Pin / Ring Type with 2,1mm pin diameter

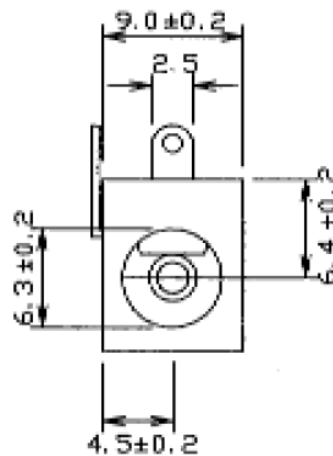

3.5 Environmental Specification

Ambient temperature

- » Operating: -40°C to +85 °C¹
- » Non-operating: -40 to +85 °C

Humidity

- » Operating: 10% to 90% (non condensing)
- » Non operating: 5% to 95% (non condensing)

3.6 MTBF

The following MTBF (Mean Time Between Failures) values were calculated using a combination of manufacturer's test data, if the data was available, and a Bellcore calculation for the remaining parts. The Bellcore calculation used is "Method 1 Case 1". In that particular method the components are assumed to be operating at a 50 % stress level in a 40° C ambient environment and the system is assumed to have not been burned in. Manufacturer's data has been used wherever possible. The manufacturer's data, when used, is specified at 50° C, so in that sense the following results are slightly conservative. The MTBF values shown below are for a 40° C in an office or telecommunications environment. Higher temperatures and other environmental stresses (extreme altitude, vibration, salt water exposure, etc.) lower MTBF values.

- » System MTBF: **tbd** hours

¹ The whole carrier board was designed to accomplish industrial temperature range. This was not possible for all connectors and chips. Following devices have a different temperature rating:

- » Audio Codec: -20°C to +85°C
- » DVI Connector: 0°C to 60°C

4 Connector Layout

4.1 Rear Panel

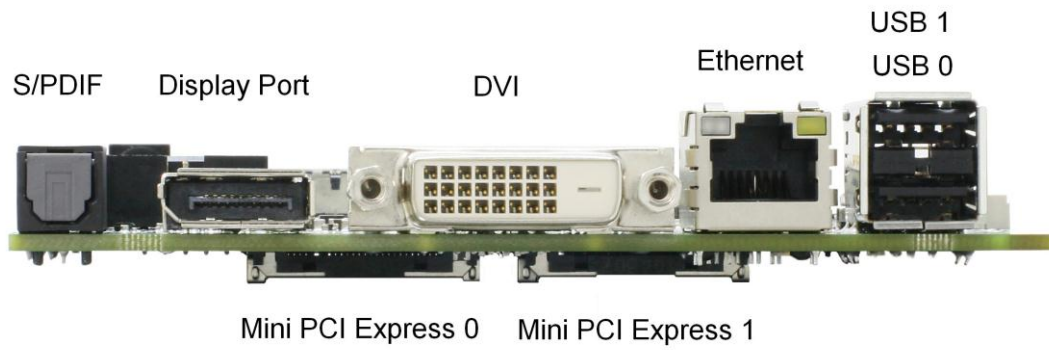

4.2 Connector Locations

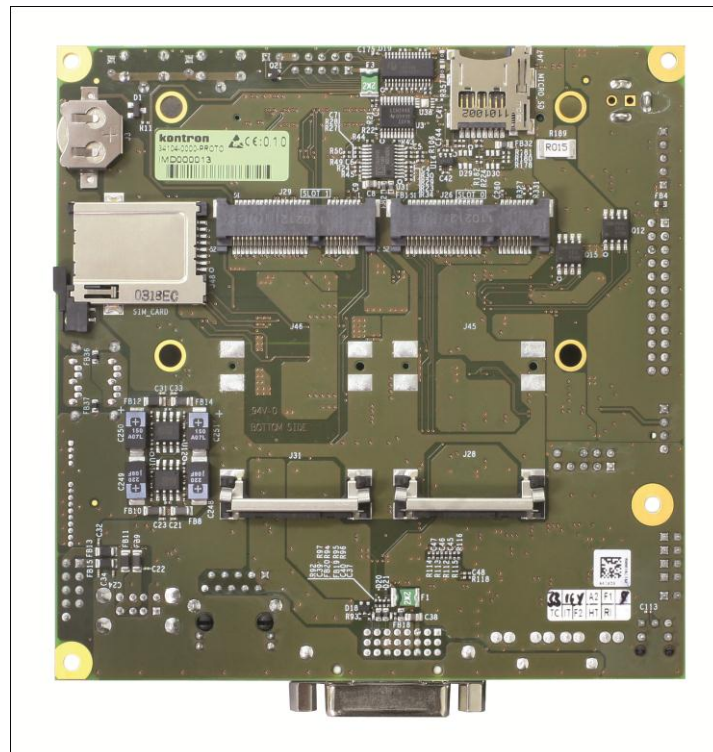
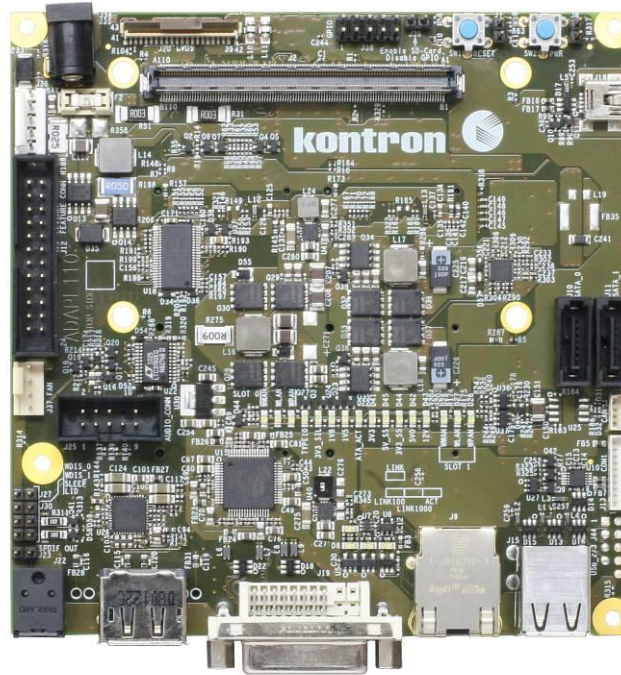

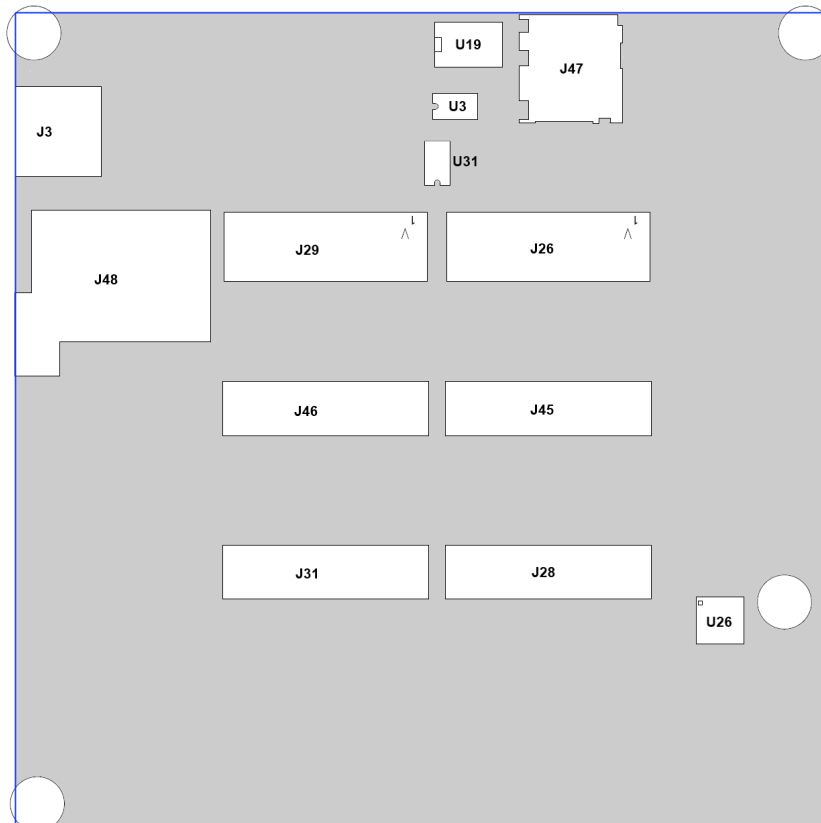
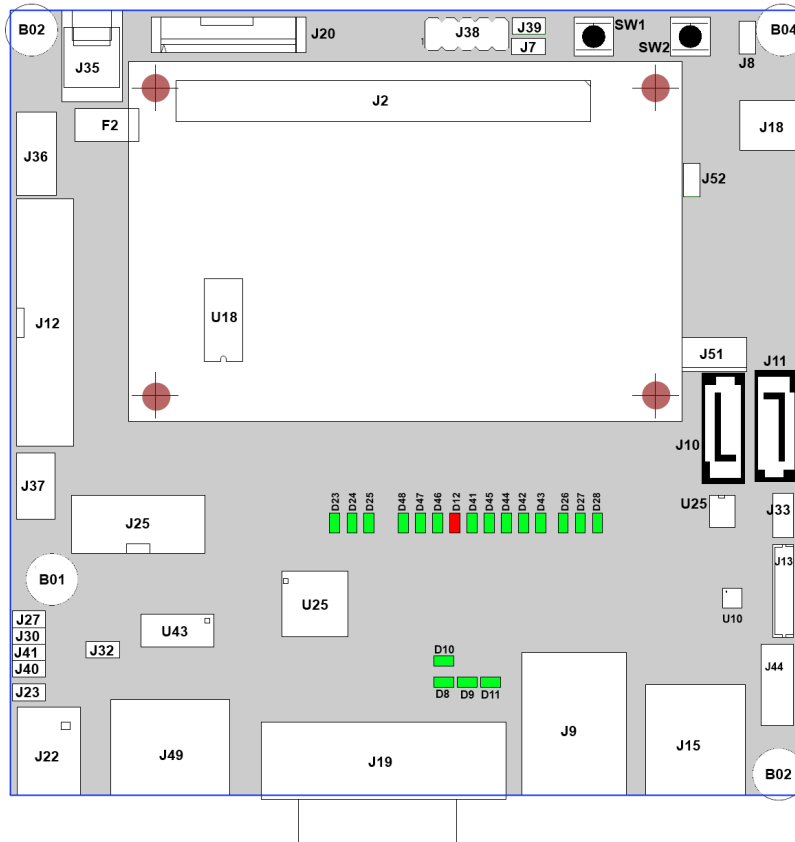

4.3 Component overview

Connector	Short Description
B01-B04	Baseboard mounting holes
D8	LAN LINK100
D9	LAN LINK1000
D10	LAN LINK
D11	LAN ACT
D12	HDD ACT
D23	Mini PCIe WWAN 0
D24	Mini PCIe WLAN 0
D25	Mini PCIe WPAN 0
D26	Mini PCIe WWAN 1
D27	Mini PCIe WLAN 1
D28	Mini PCIe WPAN 1
D41	V3.3 S0
D42	V5.0 S0
D43	V12_S0
D44	V3.3 S5
D45	V5.0 S5
D46	V1.5 S0
D47	V1.8 S0
D48	V3.3 S0 Sil
F2	Fuse
SW1	Reset Button
SW2	Power Button
J2	COM Express Connector
J3	RTC Battery Socket
J7	Reset Button Jumper
J8	Power Button Jumper
J9	Ethernet RJ45
J10	SATA #0
J11	SATA #1
J12	Feature Connector
J13	Serial COM
J15	USB #0 - #1
J18	USB Client #7
J19	DVI-D
J20	LVDS/JILI
J22	Optical S/PDIF
J23	Digital S/PDIF out
J25	Front Panel Audio
J26	Mini PCI Express 0
J29	Mini PCI Express 1
J32	Display Port/SDVO Jumper
J33	CAN
J34	DCin
J35	DCin (optional)
J36	Smart Battery
J37	Fan Connector

J38	GPIO
J39	SDIO/GPIO Jumper
J40	LID Jumper
J41	Sleep Button
J44	Frontpanel USB
J47	µSD-Card
J48	SIM Card
J49	Display Port Connector
J51	Power Connector (for HDD)
J52	S5 Eco Jumper
U3	Reset Buffer
U10	Serial Transceiver
U15	SDVO to DVI transmitter
U18	Smart Battery Manager
U19	GPIO/SDIO switch
U25	CAN Transceiver
U26	HD Audio Codec
U31	PCIe Clock Buffer
U43	Display Port – SDVO Switch

5 Connectors and Features

5.1 Power Supply

5.1.1 VCC

The COM Express® Reference Carrier Board's power supply is a single supply connection with two possible connectors. The standard connector is a pin ring type with 2.1mm pin.

Optionally a 3.5mm pitch horizontal PCB header can be equipped.

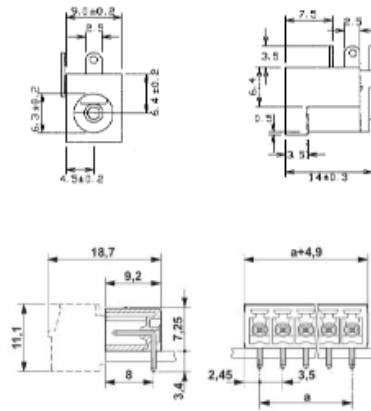
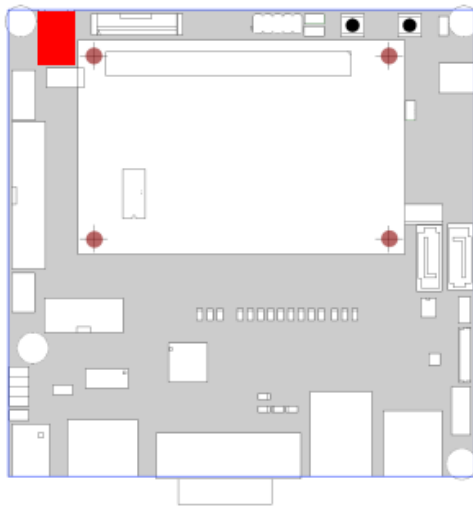

J34

J35 (optional)

Connector	Type	Matching Connector
J34	Cliff: DC10A	Cliff: DCPP1
J35 (optional)	Phoenix Contact: MC 1,5/ 2-G-3,5 (1844210)	Phoenix Contact: MC 1,5/ 2-ST-3,5 (1840366)

Connector	Pin	Signal
J34	1 (Pin)	VCC
	2 (Shield)	GND
J35	1	VCC
	2	GND

5.1.2 Power and Reset Button

Power and Reset Button is available as switch as well as jumper.

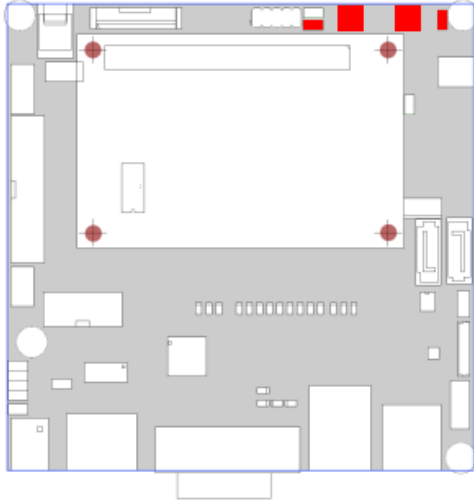

Connector	
J7	Reset Button
SW1	
J8	Power Button
SW2	

5.1.3 LID# and SLEEP# Jumper

The specifications update for PICMG COM.0 modules to revision 2.0 implements new signals for LID# and SLEEP#. The low active signals can be simulated by switch 5 and 6 similar to notebook functionality of closing the lid or pressing the sleep button.

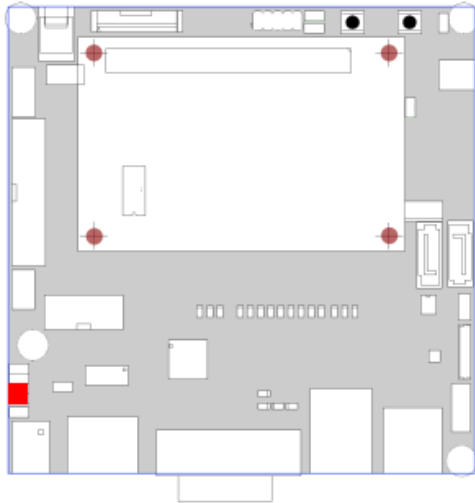



J41
J40

Connector	
J40	LID#
J41	SLEEP#

5.2 COM Express® Connector

The COMe Reference Carrier-i Type 10 is a reference backplane for Type 10 based Computer-on-Modules. Both types are module pin-outs based on one connectors with 2 rows (Row A and B) with 220 pins overall. Please refer to your module documentation for detailed pin-out descriptions.

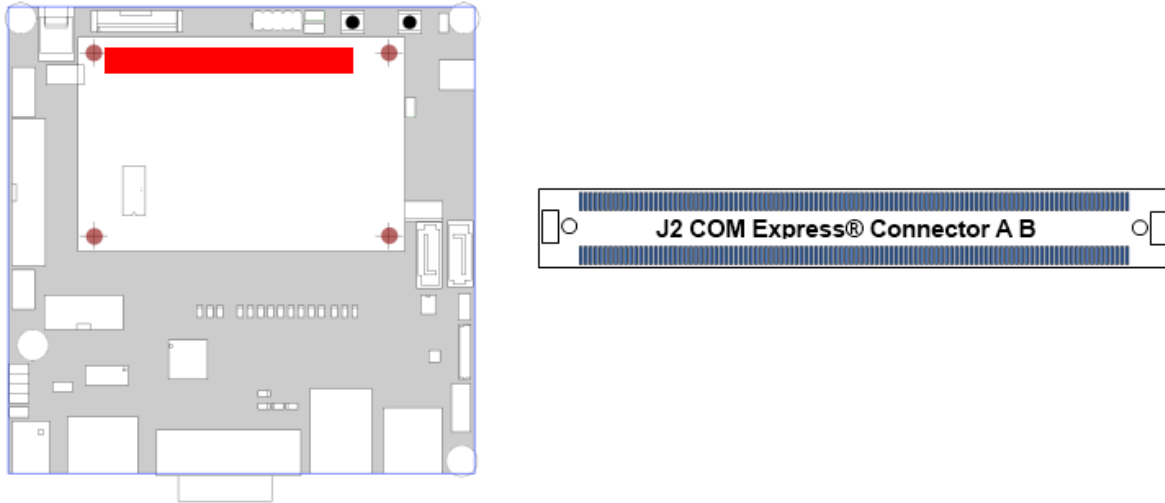

Note: The Type 10 pin-out is compatible to Type 2 and Type 6. It's possible to drive Computer-on-Modules based on pin-out Type 2 and Type 6 on this evaluation baseboard without functionality of second COM Express® connector CD and 2nd DDI on connector AB.

5.3 Status LEDs

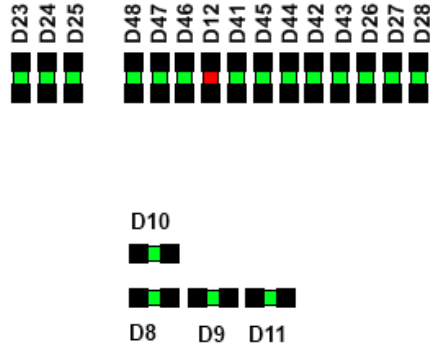
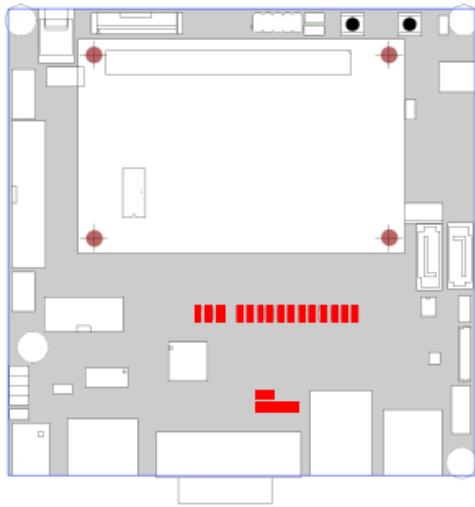

LED	Description
D8	LAN LINK100
D9	LAN LINK1000
D10	LAN LINK
D11	LAN ACT
D12	HDD ACT
D23	Mini PCIe WWAN 0
D24	Mini PCIe WLAN 0
D25	Mini PCIe WPAN 0
D26	Mini PCIe WWAN 1
D27	Mini PCIe WLAN 1
D28	Mini PCIe WPAN 1
D41	V3.3 S0
D42	V5.0 S0
D43	V12_S0
D44	V3.3 S5
D45	V5.0 S5
D46	V1.5 S0
D47	V1.8 S0
D48	V3.3 S0 for Silicon Image SIL1364

5.4 Serial ATA

The COM Express® Type 10 pin-out specification according to COM.0 specification revision 2.0 defines 2 SATA ports. The COM Express® Type 10 Reference Carrier Board provides two 7-pin SATA data connectors as standard 1.27mm Pitch Serial ATA High Speed Header with Locking Latch.

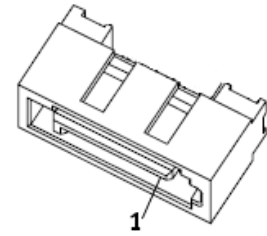
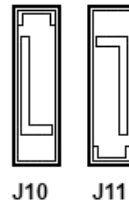
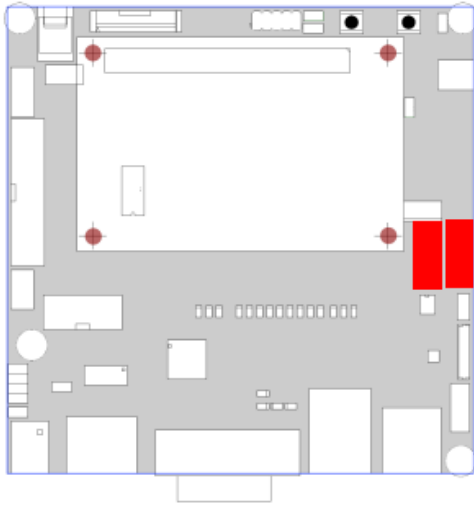

SATA Pin	Signal
1	Ground
2	Transmit +
3	Transmit -
4	Ground
5	Receive -
6	Receive +
7	Ground

Connector	SATA Port
J10	SATA #0
J11	SATA #1

5.5 μ SD-CARD / Module GPIO

The SD-Card standard is a standard for removable memory storages designed and licensed by the SD Card Association (<http://sdcard.org>). The card form factor, electrical interface and protocol are all part of the SD Card specification. COM Express® Type 1 and Type 10 pin-out based modules may provide a SDIO interface shared with GPIO signals. Therefore on COM Express® Reference Carrier Type 10 a μ SD-Card connector is available. Please check the documentation of your module if SDIO is supported and how to enable.

Close configuration jumper39 (default) to enable μ SD-Card Slot J47 or open J39 to enable GPIO pin-header J38.

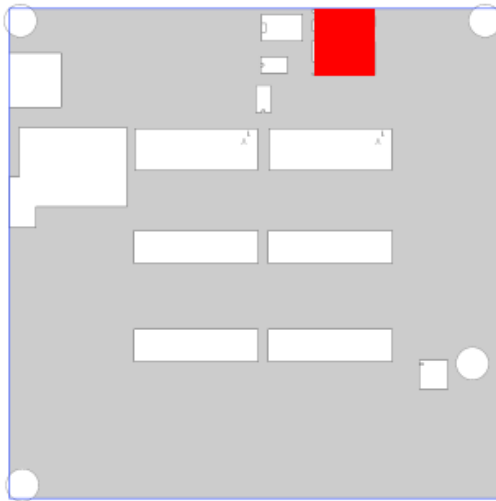

J47

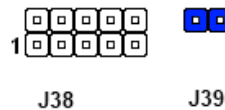
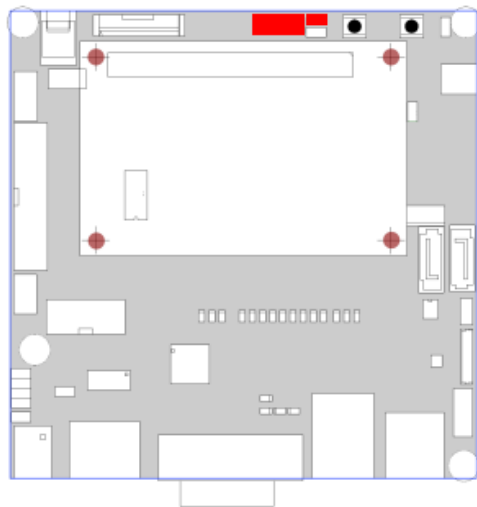
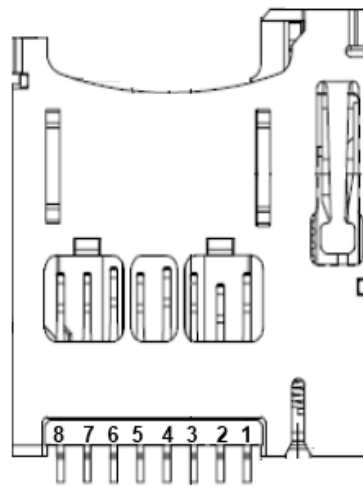

μ SD Card Pin Description

PIN	Name	Description	PIN	Name	Description
1	DAT2	Data Line 2	5	CLK	Clock Line
2	DAT3	Data Line 3 / Card Detect	6	GND	Signal Ground
3	CMD	Command/Response	7	DAT0	Data Line 0
4	Vdd	Supply Voltage - 3.3V	8	DAT1	Data Line 1

GPIO J38 PIN	Description	GPIO J38 Pin	Description
1	VCC 3.3V	2	GPO0 / SD_CLK
3	GPIO / SD_DATA0	4	GPO1 / SD_CMD
5	GPI1 / SD_DATA1	6	GPO2 / SD_WP
7	GPI2 / SD_DATA2	8	GPO3 / SD_CD#
9	GPI3 / SD_DATA3	10	GND

Note: The switching circuitry which selects GPIO or SDIO interface may influence the signal quality of SDIO which results in detection or boot issues with some fast SD/SDHC cards. Therefore it's recommended to reduce SDIO interface speed to 24MHz in module's BIOS if supported

5.6 High Definition Audio

The COMe Reference Carrier-i Type 10 provides HDAudio via AD1882AJC High Definition Audio Codec supporting analog, optical and digital audio connections.

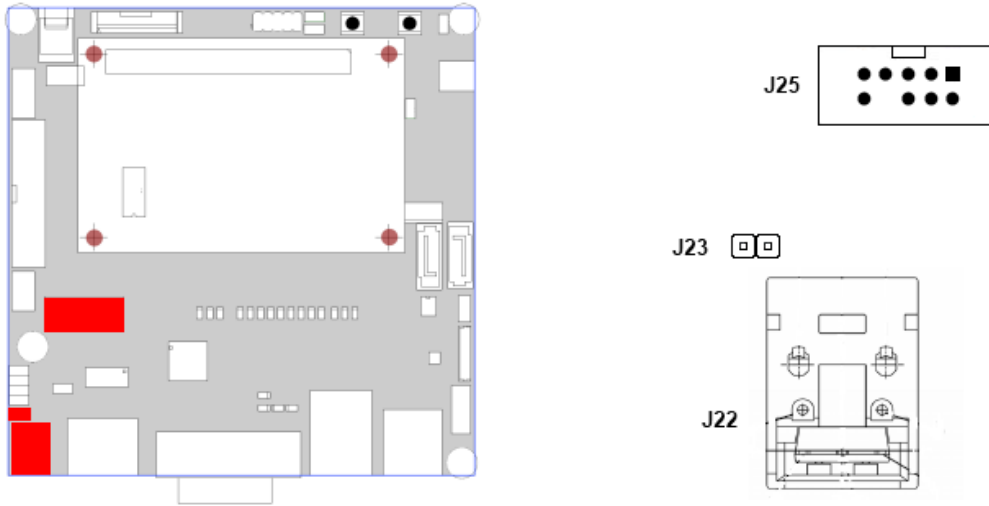

Front Panel Audio Connector J25

The Front Panel Audio Connector J25 on COMe Reference Carrier-i Type 10 allows connecting a chassis front panel audio with analog microphone input and stereo speaker output.

Pin	Description	Pin	Description
1	MIC2-L	6	MIC2-JD
2	GND	7	SENSE
3	MIC2-R (MIC Power)	8	Key Pin
4	PRESENCE#	9	Line2-L (LineOut-L)
5	LINE2-R (LineOut-R)	10	LINE2-JD

Digital Audio Output J23

Connector J23 offers a digital S/P-DIF connection.

Pin	J23 (S/PDIF out)
1	SPDIF_OUT
2	GND

Optical Audio Output J22

Connector J22 offers a TOSLINK compatible optical S/P-DIF connection.

5.7 Ethernet

The COMe Reference Carrier-i Type 10 provides a RJ45 connector. Ethernet Connector J9 with integrated magnetics and LED is configured to support modules with Gigabit Ethernet controller only. Modules with 10/100 MBit Ethernet controller are not supported.

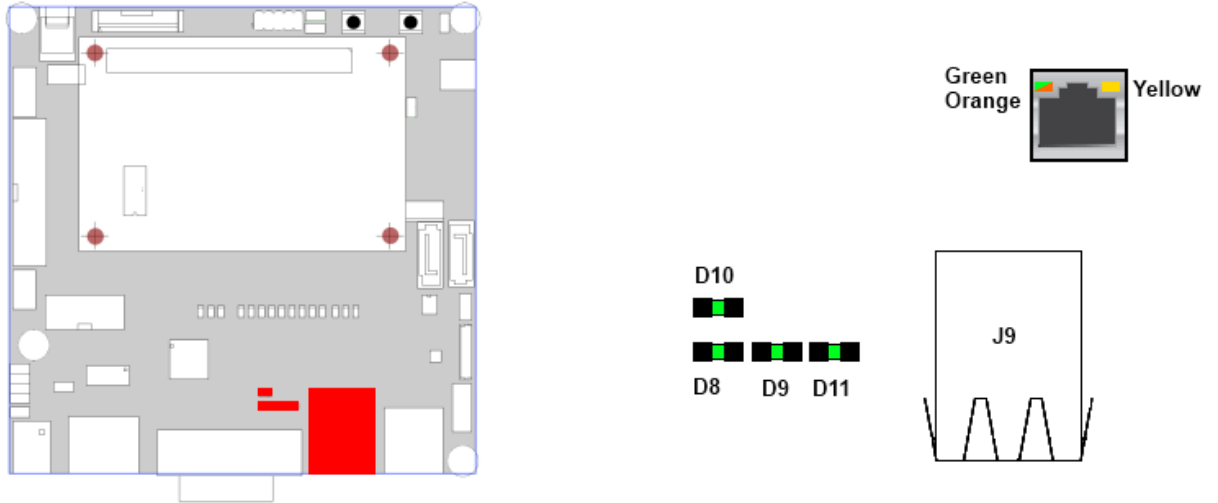

Function	J9 Left LED	J9 Right LED
Activity	-	Yellow
Link10	-	-
Link100	Green	-
Link1000	Orange	-

Carrier Board Diodes	Short Description
D8	LAN LINK100
D9	LAN LINK1000
D10	LAN LINK
D11	LAN ACT

5.8 USB

The COM Express® module's USB ports 0 to 1 are available on rear panel connector J15. USB ports 2 and 3 are located on the front panel connector. USB ports 4 and 5 are used on mini PCI express connector.

Additionally USB7 is available on USB mini-A connector J18 as non-powered connector for USB client functionality. Check the documentation of your module if USB client on Port #7 is supported and J18 can be used.

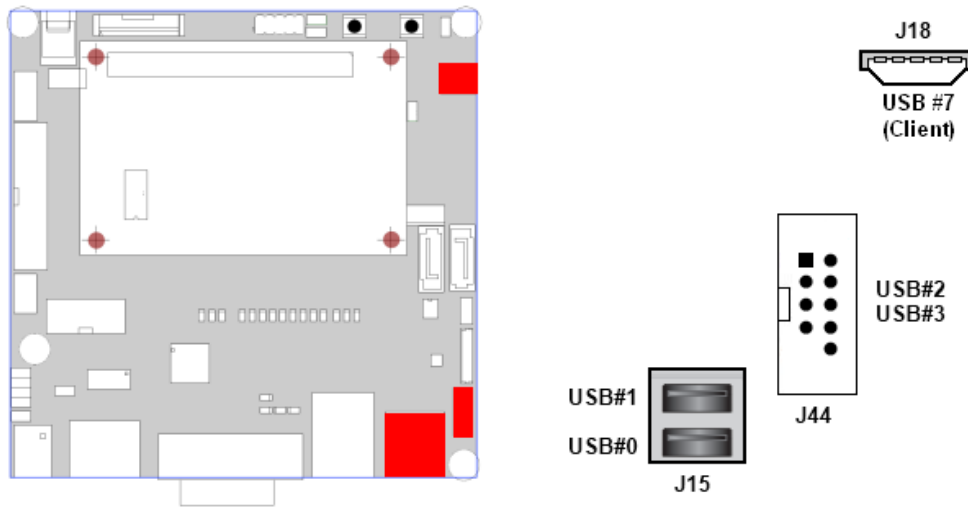

USB Client connector J18 - Pin	J18 Function
1	USB Client Power detect
2	USB7-
3	USB7+
4	n.c.
5	GND
6-9	Shield GND

USB front panel connector J44 - Pin	J3 Function
1	USB Power (+5V)
2	USB Power (+5V)
3	USB2-
4	USB3-
5	USB2+
6	USB3+
7	GND
8	GND
10	Shield GND

5.9 Mini PCI express

The COMe Reference Carrier-i Type 10 provides two full functional miniPCIexpress card sockets, one in full size one in half size. All signals are equipped: USB, PCIe and the UIM signals are connected to the SIM card socket.

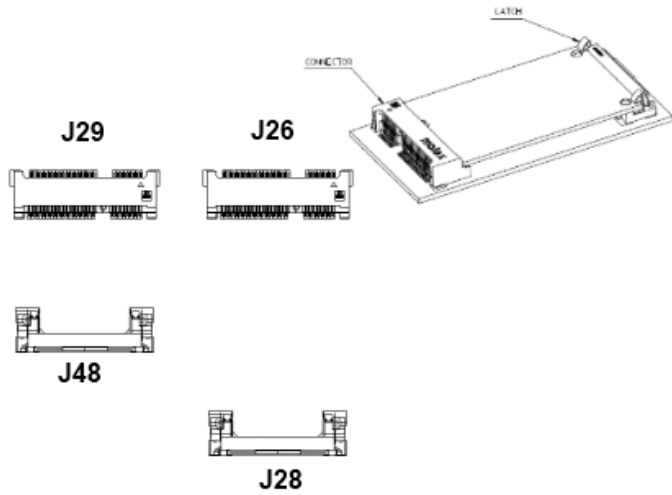
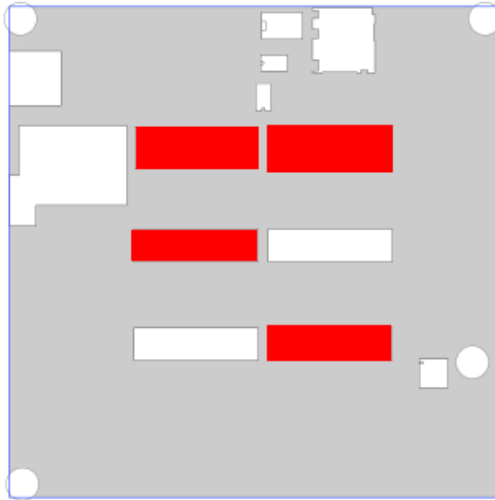

MiniPCIe J29 / J26 - Pin	Function	MiniPCIe J29 / J26 - Pin	Function
1	WAKE#	2	3,3V
3	Reserved	4	GND
5	Reserved	6	1,5V
7	CLKREQ#	8	UIM_PWR
9	GND	10	UIM_DATA
11	REFCLK-	12	UIM_CLK
13	REFCLK+	14	UIM_RESET
15	GND	16	UIM_VPP
Mechanical Key			
17	Reserved	18	GND
19	Reserved	20	Reserved
21	GND	23	PERST#
23	PERn0	24	+3,3Vaux
25	PERp0	26	GND
27	GND	28	+1,5V
29	GND	30	SMB_CLK
31	PETn0	32	SMB_DATA
33	PETp0	34	GND
35	GND	36	USB_D-
37	Reserved	38	USB_D+
39	Reserved	40	GND
41	Reserved	42	LED_WWAN#
43	Reserved	44	LED_WLAN#
45	Reserved	46	LED_WPAN#
47	Reserved	48	+1,5V
49	Reserved	50	GND
51	Reserved	52	+3,3V

5.10 SIM Card

The COMe Reference Carrier-i Type 10 provides a SIM Card connector to use radio based services on miniPCIexpress connectors J26 and J29.

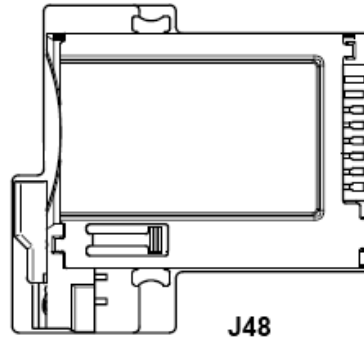
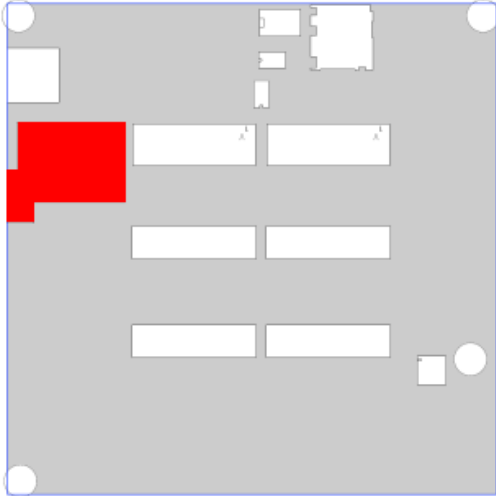

5.11 Kontron Feature Connector

The Kontron Feature connector provides additional interfaces such as I2C, SMBus or Power Control Signals. See the table below for detailed pin-out description.

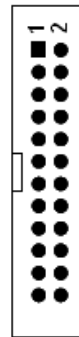
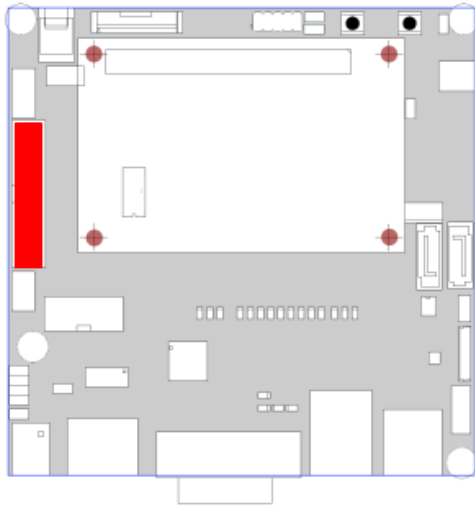

J12

Pin	Signal	Level	Signal Description
1	PWR_+5V	5V power	+5V UL-protected with inductor (600R@100MHz, 1A)
2	GPO2	3.3V-0	General-purpose power management event output
3	#BATLOW	3.3V-I	Battery low input. May be driven low by external circuitry to signal that the system battery is low, or may be used to signal some other external power management event.
4	GPI2	3.3V-I	General-purpose power management event input
5	#SYS_RESET	3.3V-I	This input may be driven low by external circuitry in order to reset the power management logic
6	WDT	3.3V-0	Indicating that a Watchdog Timeout Event has occurred (non buffered module output)
7	LPC_SERIRQ	3.3V-I	Serial interrupt request. This pin is used to support the serial interrupt protocol.
8	-	-	Not connected
9	I2C_DAT	3.3V-I0	Data line of I2C-Bus
10	#SMB_ALERT	3.3V-I	System Management Bus Alert input. May be driven low by SMB devices in order to signal an event on the SM Bus
11	I2C_CLK	3.3V-0	Clock line of I2C-Bus
12	SMB_DAT	3.3V-I0	Clock and data line of SM-Bus.
13	SMB_CLK	3.3V-0	
14	-	-	Not connected
15	#WAKE1	3.3V-I	Low driven general purpose wake-up signal
16	VCC_RTC	3V-I	3V backup cell input. Should be connected to a 3V backup cell for RTC operation and storage register non-volatility in the absence of system power. (VBATT = 2.4 – 3.3V)
17	#THRM	3.3V-I	Input from off-module temperature sensor indicating an over temperature situation
18	GND	GND	Ground
19	PWR_OK	3.3V-I	High active input indicating that power from the power supply is ready. It can also be used as low active reset input signal.
20	GND	GND	Ground
21	#PWRBTN	3.3V-I	Power Button Input. This input is used to support the ACPI Power Button function.
22	GND	GND	Ground
23	#ATA_ACT	3.3V-0	Low active output signal, which indicates activity on IDE interfaces.
24	#CB_RESET	3.3V-0	Low active Reset output from module to carrier board

5.12 DVI-D and Displayport

On COMe Reference Carrier-i Type 10 the DVI output is available through a Silicon Image SiL1364/A SDVO to single link DVI PanelLink Transmitter. Check your module documentation if SDVO is available on DDI interface defined for Type 10 pin-out based modules. If this is not the case, then please switch to Displayport usage with Jumper J32.

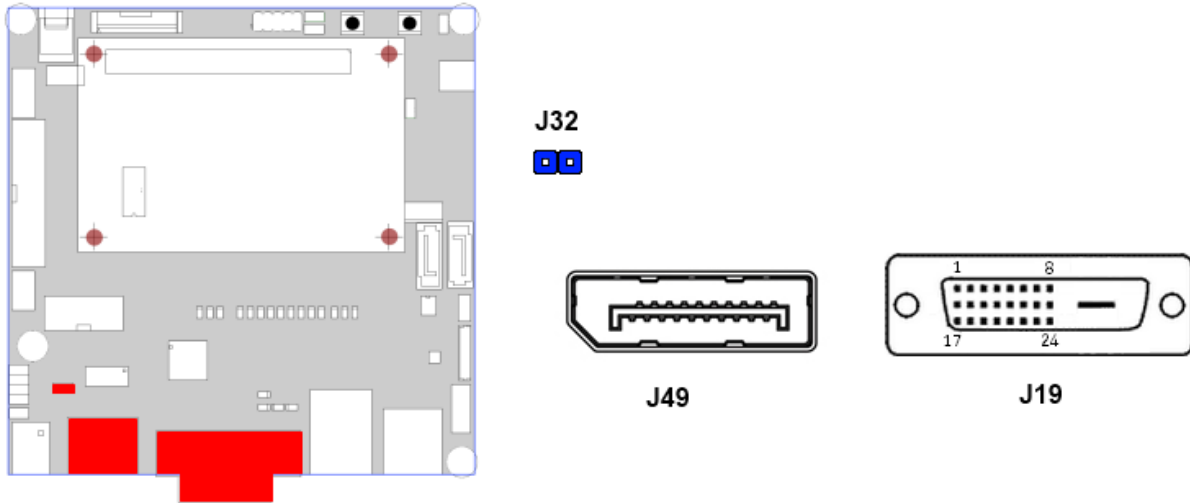

J32 Setting	Usage
Closed	DVI (default)
Open	Displayport

5.13 Serial Interface

The PICMG COM.0 specification revision 2.0 defines two optional 2-pin serial interfaces on COM Express® connector pins A98/A99 and A101/A102 formerly used for 12V VCC input. SER0 can be used as a serial COM port on COMe Reference Carrier-i Type 10 at connector J13.

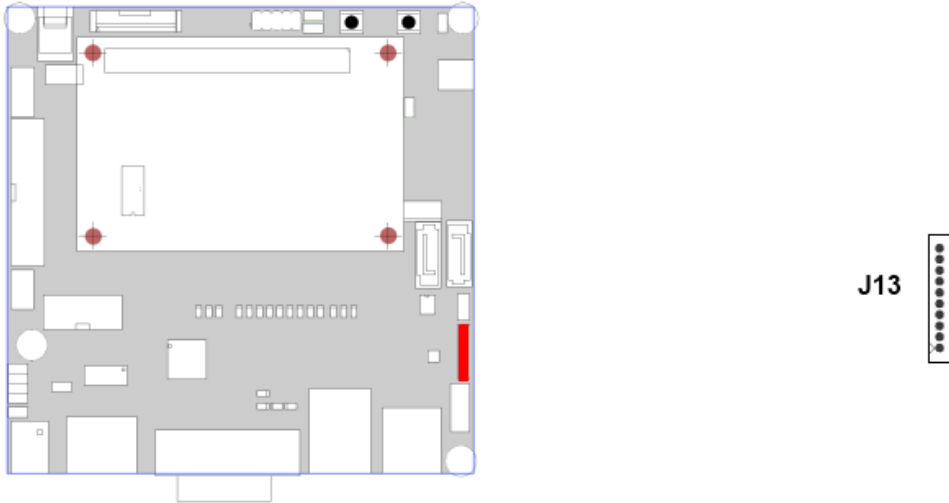

J13 allows SER0 as 2-pin RS232 interface COMA with Kontron Adapter cable [KAB-DSUB9-2](#). Please check the documentation of your module if this interface is supported and how to configure.

Pin	J13 (COMA)
1	n.c.
2	n.c.
3	RX0
4	n.c.
5	TX0
6	n.c.
7	n.c.
8	n.c.
9	GND
10	+5V

5.14 CAN

The PICMG COM.0 specification revision 2.0 defines two optional 2-pin serial interfaces on COM Express® connector pins A98/A99 and A101/A102 formerly used for 12V VCC input. On some modules the 2nd serial interface can be used as a CAN connection, which is provided by J33.

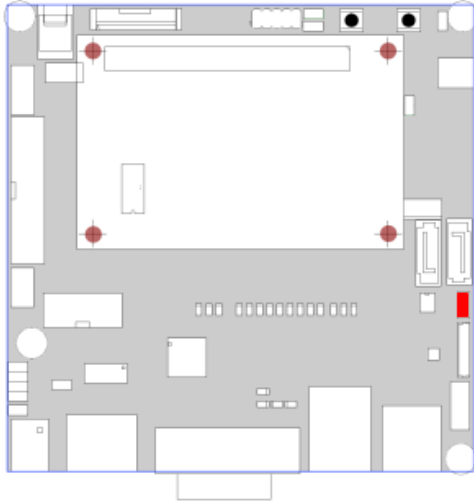

J33 allows to be used as CAN connector together with Kontron Adapter Cable [KAB-CAN-1](#).

Pin	J33 (CAN)
1	GND
2	n.c.
3	CAN_H
4	CAN_L

5.15 FAN

The COMe Reference Carrier-i Type 10 provides one 4-pin PWM FAN connector directly controlled by the module FAN output specified in the COM.0 revision 2.0 specification if supported by the module.

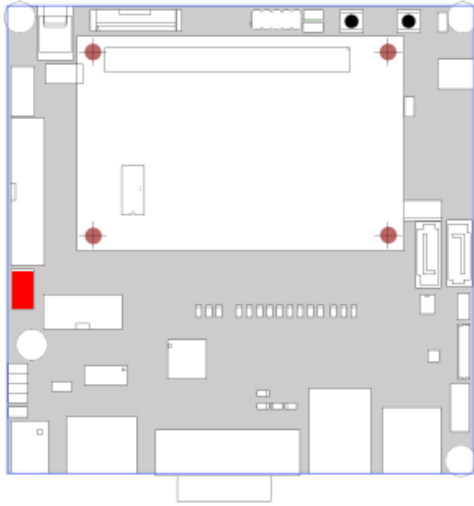

J37



Pin	J37
1	GND
2	+12V
3	Sense
4	Control (PWM)

5.16 SMART Battery

5.16.1 Introduction

The Core of the SBS is the dual Smart Battery System Manager LTC1760. On COMe Reference Carrier-i Type 10 only one battery connection is provided.

Smart Battery Systems have the ability to communicate with the application. Therefore the user gets information about the current state of the battery. The interface for this communication is the System Management Bus (SMBus). Standard Smart Batteries have a specified 5 pin header, connecting to the power lines and additionally this SMBus. This standardization allows using all available kinds of standard Smart Batteries, which also applies to the COMe Reference Carrier-i Type 10.

A typical SBS consists of a Smart Battery System Manager and a charger, which can communicate with the chipset using the SMBus. If there is no software to control the SBS via SM-bus then the system is able to run in a stand alone mode with reduced functionality, too.

The SBS was designed for the requirements of the COMe Reference Carrier-i Type 10. Additionally different kinds of Smart Batteries can be used. That means different battery chemistry and cell configurations. But it must be ensured to use standard Smart Batteries, which meet the SM-Bus standard.

Note: Please ensure that the input voltage of the COMe Reference Carrier-i Type 10 is higher than the charging voltage of the connected SMART battery. Otherwise the battery can not be charged.

5.16.2 Possible Smart Batteries

The SBS hardware is configured for a maximum charger output voltage of 8,4V and a maximum output current of 2 A. Smart Batteries with a nominal voltage of 7,2V, e.g. NiMH and NiCd with 6SxP (= 6 cells in series and x in parallel) or Li-Ion and LiPo with 2SxP (= 2 cells in series and x in parallel) are possible.

Battery Manufacturer:

http://www.moltechpower.co.uk/smart_standard_range.htm

e.g. ND2057, NH2057

http://www.inspired-energy.com/Standard_Products/standard_products.htm

http://www.emergingpower.com/oem/oem_standardpacks.htm

5.16.3 Smart Battery System Manager

The LTC1760 SBS Manager is a highly integrated level 3 battery charger and selector intended for products using dual smart batteries. Three SMBus interfaces allow the LTC1760 to servo to the internal voltage and currents measured by the batteries while allowing a SMBus Host to monitor either battery's status. Charging accuracy is determined by the battery's internal voltage and current measurement, typically better than $\pm 0,2\%$.

The LTC1760 automatically switches between power sources in less than 10 μ s to prevent power interruption upon battery or wall adapter removal. It implements all elements of a version 1.1 “Smart Battery System Manager” except for the generation of composite battery information. An internal multiplexer cleanly switches the SMBus Host to the attached Smart Battery without generating partial messages to the battery or SMBus host. The Thermistor on the battery is automatically monitored for temperature and disconnection information (SafetySignal).

Hardware programmable limits for maximum charge current and voltage improve the safety of the complete system. For more information see datasheet of LTC1760.

5.16.4 Smart Battery Connector

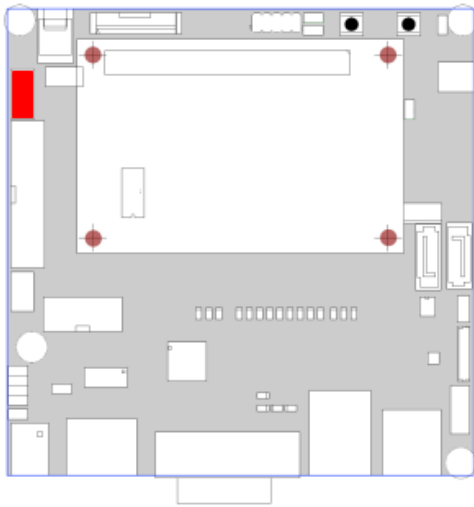

J36



6 Battery Information

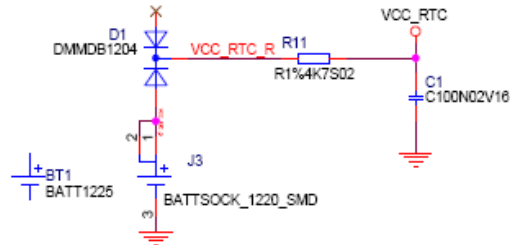
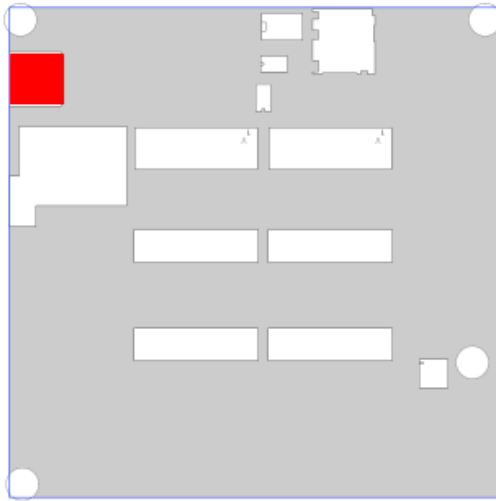

The used Battery is a BAT 1225

English:

CAUTION: Danger of explosion if battery is incorrectly replaced. Replace only with the same or equivalent type recommended by the manufacturer. Dispose of used batteries according to the manufacturer's instructions.

Deutsch:

VORSICHT: Explosionsgefahr bei unsachgemäßem Austausch der Batterie. Ersatz nur durch denselben oder einen vom Hersteller empfohlenen gleichwertigen Typ. Entsorgung gebrauchter Batterien nach Angaben des Herstellers.

French:

ATTENTION: Risque d'explosion avec l'échange inadéquat de la batterie. Remplacement seulement par le même ou un type équivalent recommandé par le producteur. L'évacuation des batteries usagées conformément à des indications du fabricant.

Danish:

ADVARSEL: Lithiumbatteri – Eksplosionsfare ved fejlagtig Håndtering. Udskiftning må kun ske med batteri af samme fabrikant og type. Lever det brugte batteri tilbage til leverandøren.

Finnish:

VAROITUS: Paristo voi räjähtää, jos se on virheellisesti asennettu. Vaihda paristo ainoastaanlaltevalmistajan suosittelemaan tyyppiin. Havita käytetty paristo valmistajan ohjeiden mukaisesti.

Spanish:

Precaución: Peligro de explosión si la batería se sustituye incorrectamente. Sustituya solamente por el mismo o tipo equivalente recomendado por el fabricante. Disponga las baterías usadas según las instrucciones del fabricante.

Note: The battery of this product is not considered to be accessible by the end user. Therefore the safety instructions are only given in English, German, French, Danish, Finish and Spanish language.

If the battery of this product however is accessible by the end user, it is in the responsibility of the Kontron customer to give the corresponding safety instructions in the required language(s).

7 Module Single Supply and Wide Range

The COMe Reference Carrier-i Type 10 is supplied via a single wide range supply between 5.5V and 20V. Please ensure that also your module supports wide range input of that range.

Please check the documentation of your product if a wide range voltage input is supported. Kontron Computer-on-Modules usually supports:

- » COM Express® modules in ultra size form factor (nanoETXexpress):
4.75V to 14V
- » COM Express® modules in compact and basic size form factor (microETXexpress and ETXexpress)
8.5V to 18V

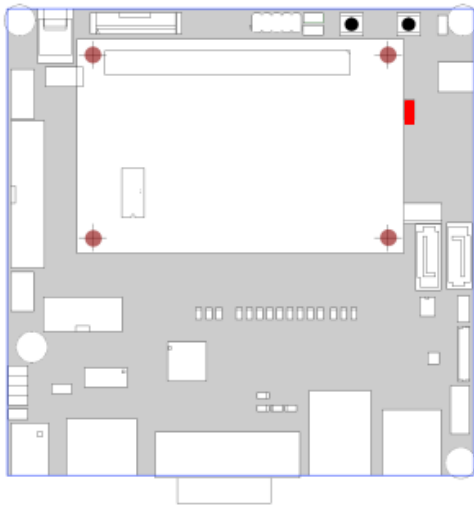

J52 

J52 enables Carrier Board's S5Eco mode, when open. Default is closed.

8 Compatibility Matrix

The COM Express® Eval Type 10 supports Computer-on-Modules following PICMG COM.0 Revision 1.0 pin-out Type 1 or COM.0 revision 2.0 pin-out Type 10.

See table below which features are supported by Kontron's COM Express® ultra form factor modules 'nanoETXexpress':

Con	Feature	nanoETXexpress-SP (Type1)	nanoETXexpress-TT (Type10)
J15	ATX 12V Power	4.75V - 14V	4.75V - 14V
J25	PCIexpress Slot A	if PCIe Switch is disabled	if PCIe Switch is disabled
J26	PCIexpress Slot B	if PCIe Switch is enabled	if PCIe Switch is enabled
J27	PCIexpress Slot C	if PCIe Switch is disabled	if PCIe Switch is disabled
J41	ExpressCard	YES, but USB#5 is USB 2.0 only	YES
J38	PCI Slot0	if PCIe Switch is enabled	YES
J39	PCI Slot 1	if PCIe Switch is enabled	YES
J41	Express Card	if PCIe Switch is enabled	YES
J34	SATA1	on variants without onboard LAN	YES
J61	USB #4 / USB #6 Ethernet RJ45	USB 2.0 only	No USB #6
J44	PWM FAN (SIO/Module)	SIO YES / Module NO	SIO YES / Module optional
J68	DVI-D (SDVO2DVI)	Optional	YES
J74	LPC FWH for external BIOS	YES	NO
J76	SPI Flash for external BIOS	NO	YES
J78	RS232 COMA from module	NO	YES
J79	RS232 COMB from module	NO	YES
J83	SERO from module	NO	YES
J84	SER1 from module	NO	YES
J92	LID	NO	Optional
SW6	SLEEP	NO	Optional

9 Security Advice

To protect the external power lines to peripheral devices the customer has to take care about:

- The wires to the external device have the right diameter to withstand the max. available current
- The housing of the external device fulfils the fire protection requirements of IEC/EN 60950.

10 Document Revision History

Revision	Date	Edited by	Changes
0.10_prelim	24.08.11	UMA	Initial Release
0.2	03.11.11	UMA	Added mechanical measures, added functional and connector description.
1.0	07.02.11	UMA	Corrected Ethernet description, added warning for low voltage use

Corporate Offices

Europe, Middle East & Africa

Oskar-von-Miller-Str. 1
85386 Eching/Munich
Germany
Tel.: +49 (0)8165/ 77 777
Fax: +49 (0)8165/ 77 219
info@kontron.com

North America

14118 Stowe Drive
Poway, CA 92064-7147
USA
Tel.: +1 888 294 4558
Fax: +1 858 677 0898
info@us.kontron.com

Asia Pacific

17 Building,Block #1,ABP.
188 Southern West 4th Ring
Beijing 100070, P.R.China
Tel.: + 86 10 63751188
Fax: + 86 10 83682438
info@kontron.cn

